

Gasenz

Oxygen Monitor

User Manual NT-UM-2107-EN-01



Issue No.	Description	Date	Author Initials
Rev 0	Original document issued for the models with serial number format 2xxxxx.	05/2024	CK
Rev 1	Updated wiring and compliance information	07/2025	CK, IM



Gasenz Oxygen Analyzer

For contact information, visit
Ntron.com

This document is the property of Ntron Gas Measurement Ltd. and may not be copied or otherwise reproduced, communicated to third parties, nor stored in any Data Processing System without the express written authorization of Ntron Gas Measurement.

© 2025 Ntron Gas Measurement

Before using your Gasenz

Safety information

Please read this manual, ensuring that you fully understand the content before attempting to install, maintain or use the Gasenz. Important safety information is highlighted throughout this document as follows:



The **warning** symbol indicates instructions that must be followed to avoid minor, serious or even fatal injury to personnel.



The caution symbol indicates instructions that must be followed to avoid damage to equipment (hardware and/or software) or the occurrence of a system failure.

NOTE highlights an essential operating procedure, condition, or statement.



Zirconia sensors operate at moderately elevated temperatures. Handling them without the correct personal protective equipment (PPE) can cause minor discomfort.

Abbreviations

AC	Alternating current
DC	Direct current
°C	Degrees celcius
°F	Degrees fahrenheit
EC	Electrochemical
ELV	Extra Low Voltage
FSD	Full-scale deflection
g	Grams
GND	Ground
kg	Kilogram
LED	Light emitting diode
LPM	Liters per minute
mA	Milliampere
O ₂	Oxygen
OEM	Original equipment manufacturer
oz	Ounces
PC	Personal computer
PCB	Printed circuit board
PLC	Programmable logic controller
PPM	Parts per million
SCFH	Standard cubic feet per hour

S-S	Solid-state
SS	Stainless steel

Contents

Before using your Gasenz	iii
Safety information	iii
Abbreviations	iii
1 Introduction to Gasenz	1
1.1 Overview	1
1.2 Sensor	2
1.2.1 Zirconia technology	2
1.2.2 Electrochemical technology	2
1.3 Status Indicator	2
1.4 Applications	2
1.5 Considerations	3
1.6 Safety approvals	3
2 Installation	4
2.1 Unpack the Gasenz	5
2.2 Locate your Gasenz	5
2.3 Mount your Gasenz	6
3 Connection	8
3.1 Wiring Your Gasenz	9
3.1.1 Connect your sensor	9
3.2 RS232	10
3.3 Analog output	10
4 Operation	11
4.1 User interface	11
4.2 Setup	12
4.2.1 Passkeys	12
4.2.2 Calibrate your Gasenz to your sensor	12
4.2.3 New sensor data	13
4.3 Menus and tasks	14
4.3.1 Adjust analog output FSD	14
4.3.2 Set 4 mA / 20 mA output	14
4.3.3 Simulate analog output	15
4.3.4 Restore factory settings	15
4.3.5 View diagnostics	15
4.3.6 Set relays	16
4.3.7 Alarm levels	17
4.3.8 Alarm hysteresis	17
5 Maintenance	19
5.1 General	19
5.2 Replace the sensor	19
5.2.1 Electrochemical	20
5.2.2 Zirconia	21
5.2.3 Re-configure	23

5.3 Considerations and troubleshooting23

6 Appendices24

Appendix A - Technical Specifications24

Appendix B - Menu list25

Appendix C - Marking drawings26

Appendix D - Quality, Recycling, and Warranty Information27

1 Introduction to Gasenz

This manual is applicable to the Gasenz oxygen monitor with a serial number in this format: 2xxxxx. If you require user documentation for Gasenz models with a different serial number format, please contact us at: ie.ntron.sales@processsensing.com.

Gasenz is mountable on a wall or vertical surface, for monitoring % oxygen volume levels in an ambient environment.

 This product is for indoor use only. If this equipment is used in a manner not specified by the manufacturer, the protection provided by this equipment may be impaired.

1.1 Overview

The Gasenz is designed for personnel protection in applications where there is a risk of oxygen-deficiency or enrichment, and in laboratory applications.

Gasenz is complete with integrated audible-visual alarms, and a long-life zirconia (ZR) or cost-effective electrochemical sensor options. Both have a measurement range up to 0...25 % O₂.



Figure 1. Gasenz (pictured with zirconia sensor)

The Gasenz module contains measurement electronics. The sensor is connected to the electronics via PCB-mounted screw terminals. The sensor operates from the exterior of the monitor and is replaceable. For further information refer to "5.2 Replace the sensor" on page 19.

Gasenz is suitable for mounting in an operational location without further mechanical protection, following a suitable risk assessment carried out by an appropriately experienced or qualified person.

Risk assessment should include:

- Potential hazards to personnel or plant from the intended use of the equipment

- Hazards when maintaining the equipment
- Further safety or environmental parameters to be considered.

1.2 Sensor

The Gasenz is designed to interface with either of the following two principal types of sensor technology:

- Electrochemical (EC)
- Zirconium dioxide (ZR)

Please refer to "Appendix A - Technical Specifications" on page 24 for full specifications.

1.2.1 Zirconia technology

These sensors are very stable over their lifespan and don't usually require calibration as frequently as some other sensor technologies.

A calibration check can be made at intervals suited to your application.

Avoid exposing the sensor to moisture or wetting, particularly if the gas for measurement contains condensable vapors or entrained liquids.

Halogens, organic vapors, H₂S and SO₄ should also be avoided as they may reduce sensor life and lead to inaccurate measurements.

1.2.2 Electrochemical technology

Ntron electrochemical sensors are galvanic cells capable of superior performance, accuracy, and stability. The operational life is typically up to 18 months and the sensor is designed to be unaffected by the presence of other background gases.

1.3 Status Indicator

A two-lamp high intensity LED light tower provides indication of **Normal/Ready** operational status or condition (green) and **Alarm** condition (red).

The **Alarm** condition is triggered when a gas measurement level (which can be preset) is reached. When the red alarm light is illuminated, a sounder will also be activated, providing personnel with both audible and visual indications of an **Alarm** condition. Refer to "4.3.7 Alarm levels" on page 17 for more information.

The light tower can be wired for either high and low O₂ indication, or low O₂ indication only.

1.4 Applications

Typically, our Gasenz oxygen monitors can be used in the following applications:

- Personnel protection
- Medical

- Laboratories
- Gas generation
- Hypoxic air fire prevention systems.

1.5 Considerations

The efficacy of the installed monitor is your responsibility.

When Gasenz is used with other equipment please consider the following:

- Temperature testing should be carried out.
- The products covered should be evaluated to the environmental conditions as defined by the standard up to 2000 m altitude and within the temperature range applicable to your sensor, refer to "Appendix A - Technical Specifications" on page 24 for more detail.
- Grounding application requires assessment.
- The current rating and size of the power supply cable should be appropriate to your equipment.
- The products covered by this manual are to be installed as per the manufacturer's instructions.
- Only the sensor provided by the manufacturer is to be used with the module.

1.6 Safety approvals



The CE marking indicates Gasenz conformity to European health, safety, safety and environmental protection directives.



Intertek

This ETL marking proves Gasenz is compliant to North America safety and industry standards.

2 Installation

NOTE: Installation, operation and maintenance of this equipment should be carried out only by appropriately trained and suitably qualified technicians in accordance with the instructions in this user manual, and any applicable standards/certificates associated with the country, industry and application.

 Failure to correctly adhere to these instructions may result in serious or even fatal injury. In this regard, the manufacturer will not be held liable.

NOTE: The operator may only perform modifications and repairs to the equipment or system with written approval from the manufacturer.

 **Do not operate damaged equipment. If faults cannot be rectified, the equipment must be taken out of service and secured against unintentional commissioning.**

Before installing your Gasenz, ensure that its specifications are suitable for the installation location.

2.1 Unpack the Gasenz

Your Gasenz monitor pack is comprised of the following equipment (pack contents may vary depending on your specification):

1. Gasenz module including sensor in sensor housing (ZR sensor pictured)
2. Spare trunking hole cover
3. Factory calibration certificate.



Figure 2. Contents of pack

2.2 Locate your Gasenz

The Gasenz is an oxygen detector system and should be installed so that it can effectively monitor a plant area where low oxygen levels could occur.



Gasenz is a 'Safe Area' device and is not suited to Hazardous Areas.

NOTE: Please ensure the module is located so that an early warning can be given if the atmosphere becomes oxygen deficient.

The following background gases should be avoided to preserve sensor life:

- Halogens
- F
- Cl
- Br
- SO_x
- H₂S
- Vapors of silicon-sealing compounds

- Adhesives.

The densities of gases in air is identified in European standard EN 617791:2000.

NOTE: High pressure gas leaks can result in a drop in gas temperature, which could temporarily increase gas density.

When choosing a suitable location consider evaluating the following:

- Gasenz dimensions (refer to [Figure 4 on page 7](#))
- Proximity to potential leak source: the monitor should be installed close to potential leak sources but not so close that they respond to inconsequential leakage
- Constituent gas to be detected
- Possibility of pressurized gas release, evaporation or liquid leaks
- Air movements, ventilation, topography, temperature - a well-designed ventilation system will incorporate a number of air changes per hour, limiting potential gas build-up or depletion of oxygen
- Number of personnel at location.

Gasenz can cover an area of around 50 m², this equates to an approximate radius of 5 meters from the monitor. If the monitor is mounted on a wall as shown in [Figure 3](#), the area covered is halved. However, applications may vary, and careful consideration is required to determine the number of monitors required.

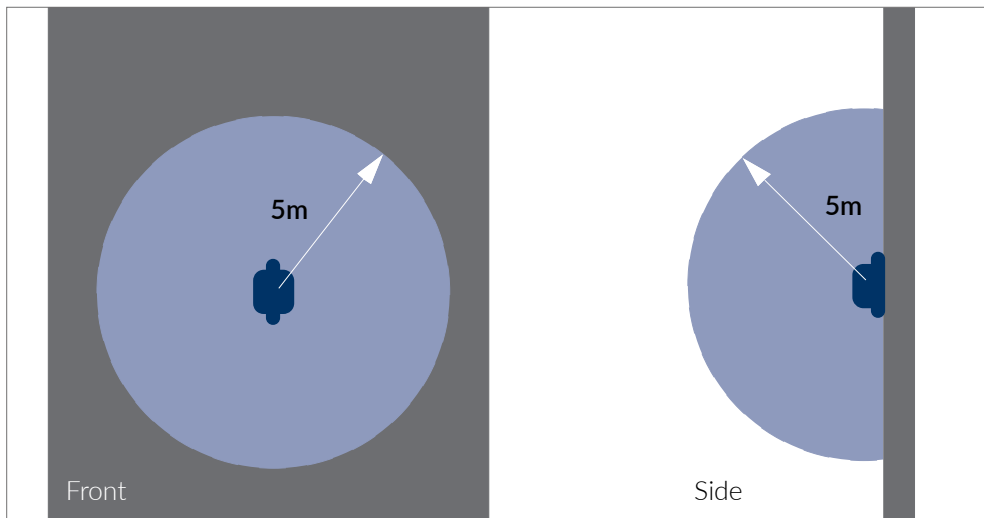

Figure 3. Monitoring coverage

2.3 Mount your Gasenz

Gasenz is suitable for mounting in an operational location without further mechanical protection, following a suitable risk assessment carried out by an appropriately experienced or qualified person.

Risk assessment should include:

- Potential hazards to personnel or plant from the intended use of the equipment
- Hazards when maintaining the equipment

- Further safety or environmental parameters to be considered.

Before mounting your Gasenz monitor, ensure that its specifications are suitable for the process, where it will be installed. See "Appendix A - Technical Specifications" on page 24.

In general, fixed systems should be installed so that maintenance of other units does not compromise the safety of the premises being monitored. Fall-back Gasenz units may therefore be required to maintain an adequate safety level.

The module can be mains powered (85...230 V AC or 24 V DC) depending on your specification.

Please ensure:

- Installation, wiring, and any upstream protective devices are provided and installed in line with the appropriate regulatory requirements for your country and industry
- A suitable cable is used, appropriate to the protective equipment installed and the connection terminal sizes on your Gasenz.

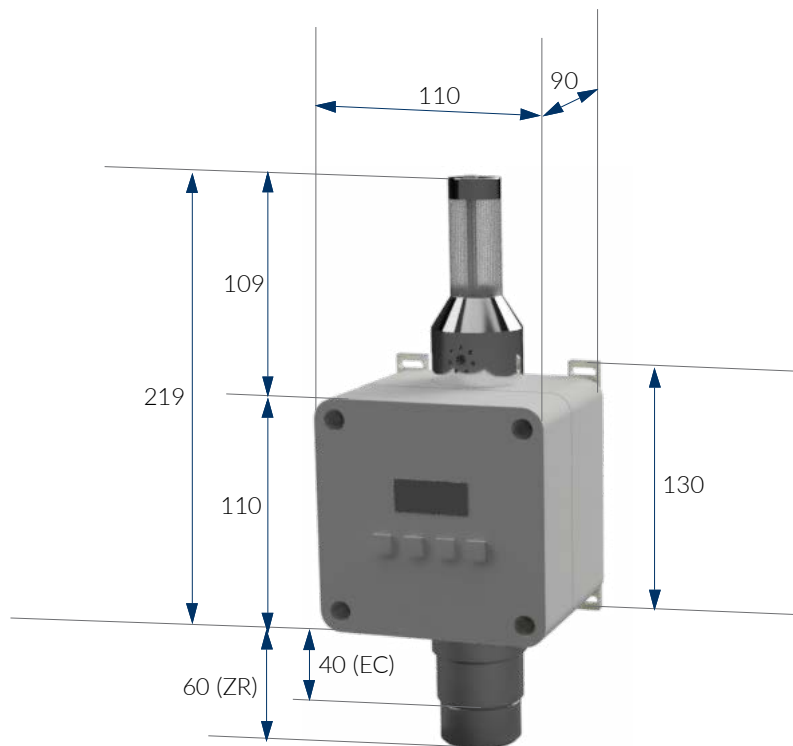

Figure 4. Gasenz dimensions (in mm)

To mount your Gasenz to a wall or vertical surface, secure the module with suitable fixings for the surface where it will be mounted.

The mounting surface should provide secure and vibration-free support, away from heat sources or sites where excessive moisture is present.

NOTE: Gasenz should be mounted upright with the light tower at the top of the module and the sensor at the bottom as shown in [Figure 4](#).

3 Connection

Your Gasenz will arrive fully wired, with your chosen sensor also wired, calibrated, and installed.

All connections to the module are provided in the form of screw terminals. The pin-outs for the module are shown below.

You are responsible for making field connections using suitable cabling in line with local regulation codes, and accounting for the power requirements for Gasenz, which are detailed in "Appendix A - Technical Specifications" on page 24.

A 500 mA anti-surge fuse is fitted to the Gasenz module and is not user replaceable. It is located next to the power input terminals.



Before switching on your monitor and sensor, ensure the voltage is correct. See "Appendix A - Technical Specifications" on page 24 for guidance.

3.1 Wiring Your Gasenz

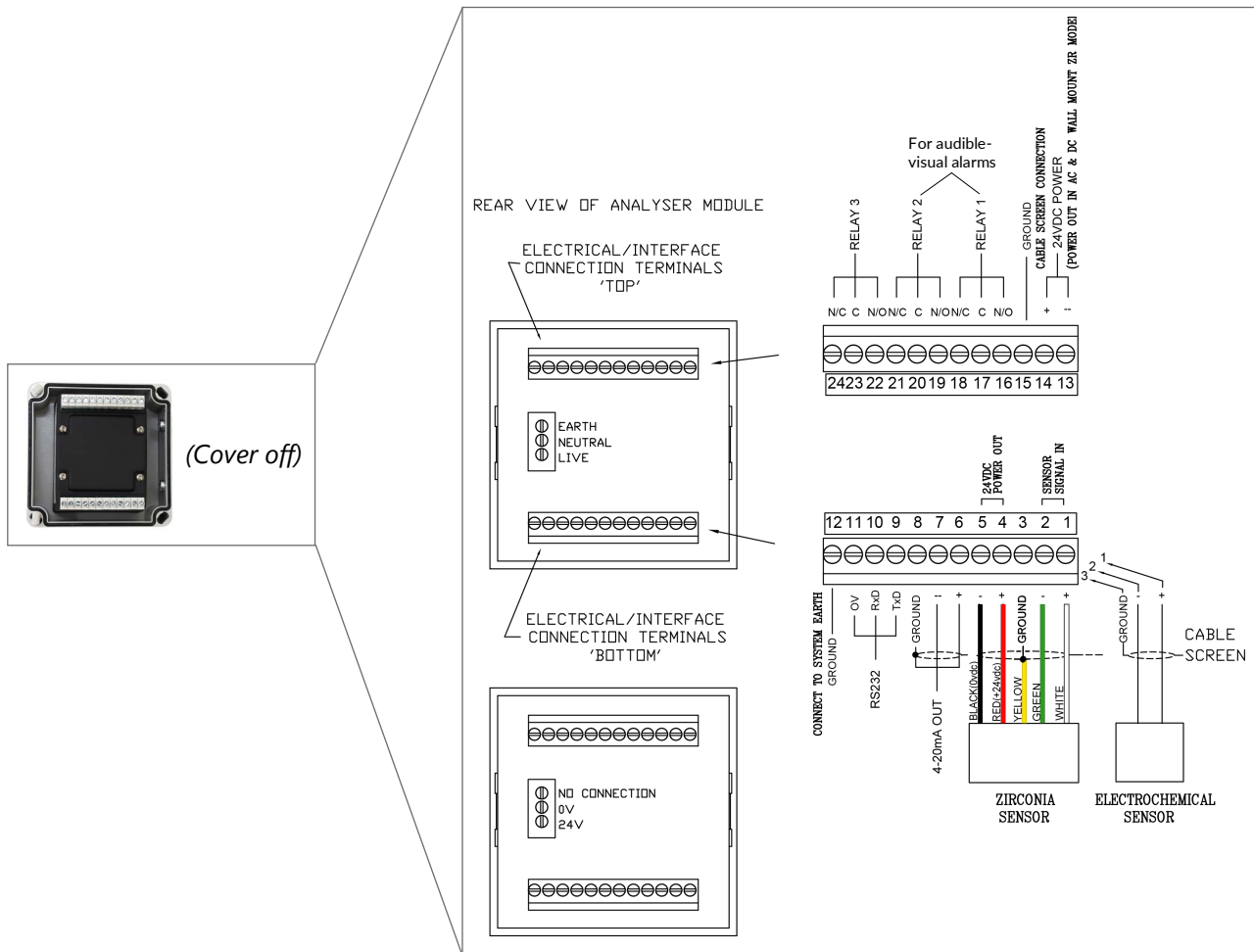

Figure 5. Terminal wiring

3.1.1 Connect your sensor

NOTE: EC and ZR sensors should be connected at terminals 1...3 (inclusive). Terminals 4 and 5 should be used only to connect ZR sensors, as shown in [Figure 5](#).

ZR sensors operate at moderately elevated temperatures, which can cause minor discomfort if in contact with unprotected hands and fingers for a prolonged period.

3.2 RS232

If you require RS232 connection, please contact us:

Email: ie.ntron.sales@processsensing.com

Phone: +353 46 907 1333.

3.3 Analog output

Analog output enables communication of detected gas levels with external equipment (such as data loggers, remote displays). The output is equal to the current source (4...20 mA), where 4 mA represents zero gas and 20 mA represents gas at the sensor FSD.

4 Operation

When Gasenz is first powered up, all the display segments are displayed followed by the start-up display sequence below:

- Software version number
- The company name
- The sensor type
- The gas level.

On completion of the display sequence, the module is operational.

4.1 User interface





The Gasenz has a 1-inch LCD display and a four-key keypad interface.



Figure 6. Gasenz user interface

The keypad buttons can be used as identified in the table below:

Table 1: Interface key functions

Key	Function	Additional function
	Menu open/close	
	Enter	Number 1
	Next (increment)	Number 2
	Previous (decrement)	Number 3

4.2 Setup

The menu system enables calibration and configuration of your module to your equipment. Refer to "Appendix B - Menu list" on page 25 for guidance.









4.2.1 Passkeys

Gasenz uses a passkey system to restrict changes that could compromise use of the equipment. The factory set passkey for **level 2 access is 1331**. For **level 3 access, the passkey is 12231**.

The passkey feature can be enabled or disabled. There are three menu access levels (1, 2, and 3) and each level allows access to specific menu options. See "Appendix B - Menu list" on page 25 for details.

When a particular menu level is accessed, the user has 10 seconds to enter a specific menu on the chosen level before automatic exit is carried out. On accessing a menu, the user then has 10 minutes to make adjustments and save changes.





To enable the passkey function:





1. Press .
2. Using the  and  buttons, select menu option E:20.
3. Press . The display will show the current status as On or Off.
4. Use the  and  keys to select your desired status.
5. Press  to save your changes.
6. Press  to exit.

4.2.2 Calibrate your Gasenz to your sensor

Your calibration requirements and frequency will vary depending on your sensor technology and application. You should determine a reasonable schedule according to these factors and your own requirements.

To calibrate Gasenz to your sensor:

1. Press  on the keypad.
The word "PASS" will appear on the display. You will require level 3 access to change this setting.
2. Enter the passkey for level 3 access.
The numerical combination can be entered using the keypad. Please refer to "Table 1: Interface key functions" on page 11. As each key is pressed the letters "Po" will be displayed on the screen.
3. Once the passkey is entered, press .
4. Use the  and  keys to select E:1.

5. Press . Allow time for the sensor to respond (approximately 2 minutes in ambient air, a lower Oxygen concentration may require more time for the reading to stabilize).
6. Use the  and  keys to set the reading to that of the calibration gas level.
7. Press  to span the sensor, “_ _ _ _” will appear on the display to confirm calibration.





NOTE: Pressing  instead of  will exit without saving.

8. Wait until the reading is stable before pressing . If it is unstable press  to span the sensor.
9. Press  to exit.

NOTE: The sensor reading will be displayed as a % value on exit when the  button is pressed. This value is a percentage of the initial calibration value set via New Sensor Data in menu E:14. Each time a new sensor is connected and calibrated, the New Sensor Data should be set.

4.2.3 New sensor data

You can use this function to set the initial sensor calibration data. It enables you to periodically check the percentage of your sensor's capacity.

1. After entering your menu level, use the  and  keys to select E:14.
2. Press . The display shows 100. This indicates that your sensor is at 100 % functionality.
3. Press  again to store the new sensor data to the module's memory.





NOTE: Pressing  instead of  will exit without saving.

Press  to exit.







4.3 Menus and tasks

NOTE: The menus and functions available will vary according to your sensor and Gasenz firmware.

To access the menus:

1. Press  on the keypad.
The word "PASS" will appear on the display. For access to level 1 options, press  again, otherwise proceed to step 2.
2. Enter the passkey for your menu level access.
The numerical combination can be entered using the keypad. Please refer to "Table 1: Interface key functions" on page 11. As each key is pressed the letters "Po" will be displayed on the screen.
3. Once the passkey is entered, press .
4. Use the  and  keys to select the required menu.

4.3.1 Adjust analog output FSD







1. After entering your menu level, use the  and  keys to select E:2.
2. Press .
3. Use the  and  keys to adjust the FSD to the required level.
4. Press  to save your changes.

NOTE: Pressing  instead of  will exit without saving.

5. Press  to exit. The sensor FSD will be displayed when you press the  key to exit.

4.3.2 Set 4 mA / 20 mA output

Monitor the current sourced from the analog output of the OEM module using a multimeter set to read milliamps.

1. After entering your menu level, use the  and  keys to select E:3 (select E:4 for 20 mA output).
2. Press .
3. Use the  and  keys to adjust the output to 4 mA (or 20 mA).
4. Press  to save your changes.

NOTE: Pressing  instead of  will exit without saving.

5. Press  to exit.

The 4 mA or 20 mA factor will be displayed when you press the  key to exit.

4.3.3 Simulate analog output

The analog output can be tested for functionality, allowing you to simulate analog output.

1. After entering your menu level, use the  and  keys to select E:5.

2. Press .

3. Use the  and  keys to adjust the analog output. The value displayed will be equivalent to the analog output.



4. Press  to exit.

The module will return to its current analog output settings.

4.3.4 Restore factory settings

You can restore configuration to the default values using this function.

NOTE: Factory restore will overwrite all previous calibration data for the selected sensor excluding those set at the factory.

1. After entering your menu level, use the  and  keys to select E:6.

2. Press and hold  until "____" is displayed. Your module is now restored to its factory settings.

3. Press  to exit.

4.3.5 View diagnostics

This is a view-only feature. Configuration changes cannot be made.

1. After entering your menu level, use the  and  keys to select E:8.

2. Press . The display will alternate between the current value and diagnostic code.

3. Use the  key to select the diagnostic code.

4. Press  to exit the menu.

4.3.6 Set relays

NOTE: Changing this setting will alter the operating point of the indicator unit and relays which will affect the monitor’s capability to announce dangerous Oxygen levels.

Gasenz is fitted with three relays that operate in conjunction with one of three alarm levels. You can configure them using this function.

Relay 1, or relays 1 and 2 are configured and wired to operate the light tower indication unit, making them unavailable for other assignment. The relays that are not used for the light tower are available for you to connect.

Relay 3, and relay 2 (if available) are volt-free contacts, 6A @ 250 V AC rated.









- Relay 1 is associated with alarm level 1
- Relay 2 is associated with alarm level 2
- Relay 3 is associated with alarm level 3.

You can choose energize “E” or de-energize “D” each relay when the module alarms are inactive.

Relays can also be set to act on rising “R” or falling “F” gas levels.

Typical operational settings		
High	O ₂ = 23%	Rising alarm
Low	O ₂ = 19%	Falling alarm

If High and Low level alarm functionality is required, then only one interface relay will be available to you for external connection. If only Low level alarm functionality is required, you will have two interface relays to connect to.

1. After entering your menu level, use the  and  keys to select E:17.
2. Press . The display shows r:1.
3. Use the  and  keys to select a relay.
4. Press , then use  and  keys to choose from the following options:
 - E:r Normally energized, rising alarm
 - d:r Normally de-energized, rising alarm
 - E: F Normally energized, falling alarm
 - d:F Normally de-energized, falling alarm.
5. Press  to store the new data.

NOTE: Pressing  instead of  will exit without saving.

6. Press  to exit.

4.3.7 Alarm levels









NOTE: Gasenz is factory configured with standard alarm level settings unless you have specified your requirements. Changing this setting will alter the operating point of the indicator unit and relays which will affect the monitor's capability to announce dangerous Oxygen levels.

Relays 1 and 2 are factory configured for 19% volume O₂ falling (Relay 1) and 23% volume O₂ rising (Relay 2). Relay 3 is set at 25% rising by default.

NOTE: For guidance, 19.5% is the OSHA-recognized US lower alarm level for O₂ depletion.

Set the alarm level operation using this function.

- Alarm level 1 is associated with relay 1
- Alarm level 2 is associated with relay 2
- Alarm level 3 is associated with relay 3.

1. After entering your menu level, use the  and  keys to select E:18.
2. Press . The display shows A:1.
3. Use the  and  keys to select an alarm level.
4. Press  , then use  and  to set the alarm level value.
5. Press  to save your changes.







NOTE: Pressing  instead of  will exit without saving.

6. Press  to exit.

4.3.8 Alarm hysteresis

A hysteresis value is associated with the alarm levels to avoid relay chattering as the unit enters and exits alarm conditions. It is displayed as a percentage point, between 1 and 10, of the alarm set.

 **Setting a value of 1 disables the relays.**

1. After entering your menu level, use the  and  keys to select E:19.
2. Press . The display shows the alarm hysteresis level.
3. Use the  and  keys to set the level.
4. Press  to save your changes.

NOTE: Pressing  instead of  will exit without saving.

5. Press  to exit.

5 Maintenance

The Gasenz will provide reliable and fault-free service for many years if cared for correctly.

5.1 General

To maintain performance, the sensor in your Gasenz module will require replacement. Please check "Appendix A - Technical Specifications" on page 24 for frequency. During sensor replacement, it is recommended that light cleaning and a routine inspection is carried out.

 **Never use chemical cleaning agents or high pressure water or steam to clean the equipment. Do not submerge in water.**

To carry out routine maintenance and inspection:

1. Use a clean, damp cloth to clean the gas detector head.
2. Ensure the sensor housing aperture is not obstructed (where applicable).

The maximum interval between routine inspections should be assessed by the person carrying out calibrations. It will depend on your application and the environment in which the module is installed.

5.2 Replace the sensor

When your sensor reaches the end of its serviceable life, calibration can no longer be performed and the sensor must be replaced.

A regular program of calibration will mitigate against sudden sensor failure. It is advisable to establish a program of preventative maintenance to ensure process downtime is kept to a minimum or avoided.

Your new sensor should only be removed from its packaging when your Gasenz is installed and ready to begin gas measurement.



The Gasenz module and sensors can be mains powered (110...240 V AC).

Ensure that any installation wiring and upstream protective devices are provided in line with the regulatory requirements for your country and industry. See "Appendix A - Technical Specifications" on page 24 for guidance.

To replace your sensor, you will need:

1. Cable tie (ZR only)
2. 2.5 mm hex-driver
3. 3 mm flat-head screwdriver (ZR only)
4. Snips (ZR only)
5. Large flat-head screwdriver (ZR only).

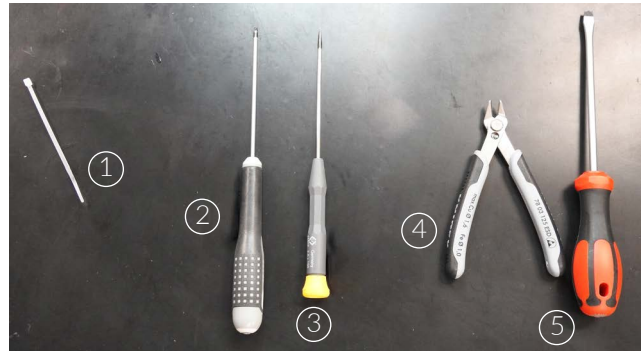

5.2.1 Electrochemical

1. Disconnect the power to your Gasenz.
2. Remove the screws from the bottom of the sensor housing using a 2.5 mm hex-driver, as shown in [Figure 7](#).
3. Remove the cover to reveal the electrochemical sensor.
4. Gently unplug the old sensor.

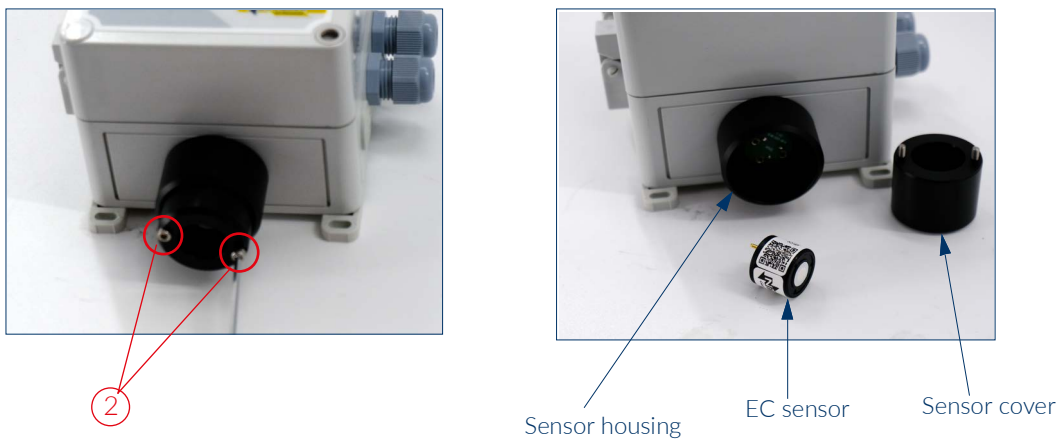



Figure 7. Replacing the EC sensor

5. Remove the new sensor from its packaging and plug it into the PCB inside the sensor housing, ensuring it is correctly aligned.
6. Close and secure the sensor cover using the 2.5 mm hex-driver. Now restore power.
7. Follow instructions for calibration in "4.2.2 Calibrate your Gasenz to your sensor" on page 12 and/or "4.2.3 New sensor data" on page 13.

8. Dispose of the old sensor appropriately, adhering to local codes.

 Electrochemical sensors contain a corrosive electrolyte and must not be opened, neither should sealed membranes be removed. Eye and hand protection must be worn if the sensor is leaking. Wipe and flush any electrolyte spillage.

Electrolyte can be fatal if swallowed.

5.2.2 Zirconia

NOTE: ZR sensors should be connected at terminals 1...3 (inclusive) as shown in [Figure 5](#).

 ZR sensors operate at moderately elevated temperatures which can cause minor discomfort if in contact with unprotected hands and fingers for a prolonged period.

1. Disconnect the power to your Gasenz. Ensure the sensor has cooled down before continuing.
2. Using a large flat-head screwdriver, open the main Gasenz casing.
3. Remove the hex screws located on the inside of the Gasenz using a 2.5 mm hex-driver, as shown in [Figure 8](#) (highlighted in red).
4. With a 3 mm screwdriver, loosen the sensor terminal screws (as highlighted in blue in [Figure 8](#)) to disconnect the sensor from the module.
5. Use snips to remove the cable tie holding the wires together.

6. Gently remove the old sensor in its housing from Gasenz.

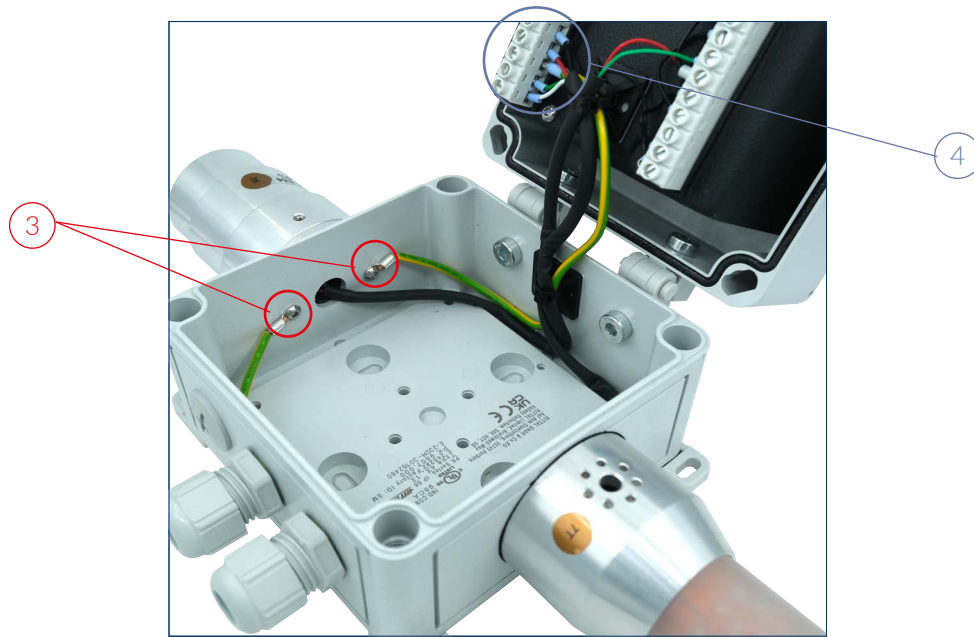

Figure 8. Replacing the ZR sensor

7. Remove the new sensor (in its housing) from its packaging.
8. Thread the wires through the hole at the base of Gasenz to bring them inside the main housing.
9. Align the screw holes with those on the Gasenz (highlighted in red in [Figure 8](#)).
10. Connect the new sensor using the 3 mm screwdriver to tighten the appropriate terminal screws. Refer to [Figure 5 on page 9](#) for guidance.
11. Secure the cables inside the Gasenz housing using a cable tie. Use snips to remove any excess.
12. Take the 2.5 mm hex-driver to tighten the hex screws that attach the sensor housing to the base of your Gasenz.
13. Close the Gasenz cover and secure it using the large flat-head screwdriver. Now restore power.
14. Follow instructions for calibration in "4.2.2 Calibrate your Gasenz to your sensor" on page 12 and/or "4.2.3 New sensor data" on page 13.
15. Dispose of the old sensor and sensor housing appropriately, adhering to local codes.

5.2.3 Re-configure

The diagram below shows the sequence for setting up Gasenz after replacing the sensor.

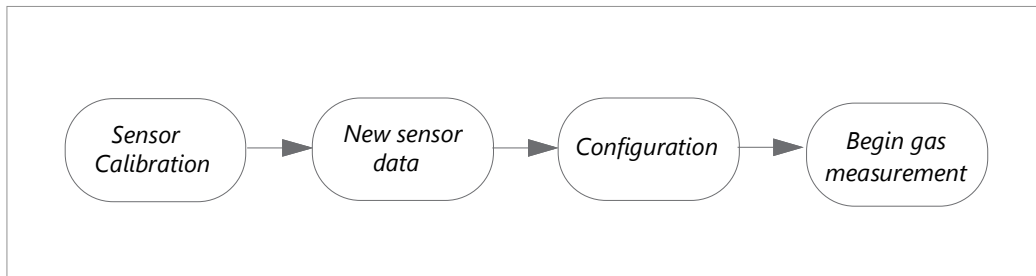

Figure 9. Gasenz setup sequence

NOTE: Gasenz must be correctly configured for the sensor being used before carrying out any other tasks.

5.3 Considerations and troubleshooting

- A faulty sensor or one that is incorrectly installed will display 'FLT' on your Gasenz display.
- Do not expose the sensor to moisture in an un-powered state. If this happens, allow the sensor to dry out.

6 Appendices

Appendix A - Technical Specifications

Sensor		
	Zirconia (ZR)	Electrochemical (EC)
Measurement Range		0...25 %
Output Resolution		0.01 %
Pressure Range		900...1100 mBar _{abs}
Response time (T90)	< 15 seconds within selected range @ 25 °C (77 °F) within selected range	
Operating Temperature Range	-25 °C...+60 °C (-13 °F...+140 °F)	0 °C...+45 °C (+32 °F...+113 °F)
Life Expectancy	Up to 5 years	Up to 18 months
Humidity	0...95 %rh non-condensing (with normal use)	
Shelf Life	Unlimited	Up to 3 months
Calibration Interval (application dependent)	12 months	3...6 months
Monitor		
Electrical		
Display	LCD, %O ₂	
Output Signal	4...20 mA	
Digital Communications	RS232	
Relay Output Options	1 off relay, dry contact 5 Amp-rated (2 relay outputs assigned to control light tower indicator)	
Power Supply	85...230 V AC (50...60 Hz) or 24 V DC	
Maximum Power Consumption	7.2 W	3.6 W
Indicators	LCD, audible and visual alarms	
Mechanical		
Housing Material	ABS	
Mounting	Wall / vertical surface	
Standards and Certification		
ETL: UL-61010-1, EMC: EN 50270		

Appendix B - Menu list

Menu option	Task
E:1	Calibrate sensor
E:2	Analog output FSD
E:3	Set 4 mA
E:4	Set 20 mA
E:5	Analog output simulation
E:6	Factory restore
E:8	Diagnostics
E:14	New sensor data
E:17	Relay
E:18	Alarm levels
E:19	Alarm hysteresis
E:20	Password enable/disable



- = Accessible by all users
- = Accessible with password levels 2 & 3
- = Access with password level 3 only

- = No password
- = 1331
- = 12231

NOTE: Available menu options may vary according to firmware version and sensor type.

Appendix C - Labels

Gasenz monitor label

 MODEL: GASENZ P/N:02-354 S/N: 200000 			
SUPPLY: 100-240 VAC, 50-60Hz, 250mA Navan, Co. Meath, Ireland. Ph:++353 46 9071333 Fx:++353 46 9071331			
25. Mains In Live 26. Mains In Neutral 27. Mains In Earth	13. 24VDC - 14. 24VDC+ 15. No Connection 16. Relay 1 N/O 17. Relay 1 Comm 18. Relay 1 N/C 19. Relay 2 N/O 20. Relay 2 Comm 21. Relay 2 N/C 22. Relay 3 N/O 23. Relay 3 Comm 24. Relay 3 N/C	1. Sensor White + 2. Sensor Green - 3. Yellow (Screen) 4. Sensor Red 5. Sensor Black 6. 4-20mA + 7. 4-20mA - 8. 4-20mA Ground 9. RS232 Tx 10. RS232 Rx 11. RS232 0V 12. System Ground	27. Mains In Earth 26. Mains In Neutral 25. Mains In Live

Gasenz zirconia sensor label

Mullaghboy Ind. Est. Navan, Co. Meath, Ireland. Tel: ++353 46 9071333 Fx: ++353 46 9071331 Email: info@ntron.com		 OXYGEN SENSOR	Part No: 02-333 Date: 06/25 Serial No.: 350000 SUPPLY: 24 Vdc, 200mA
--	--	--	---

Appendix D - Quality, Recycling, and Warranty Information

Ntron is part of the Process Sensing Technologies (PST) group and complies with applicable national and international standards and directives.

Full information can be found on our website at <https://www.processsensing.com/en-us/compliance>.

The compliance site contains information on the following directives:

- ATEX (equipment for explosive atmosphere)
- REACH (Registration, Evaluation, Authorization, and Restriction of Chemicals)
- RoHS (Restriction of Hazardous Substances in electrical and electronic equipment)
- ETL (The ETL mark is proof of product compliance to North American safety standards.
- WEEE (Waste Electrical and Electronic Equipment recycling)
- Recycling policy
- Warranty and returns.



ProcessSensing.com

© 2025 Ntron Gas Measurement
