

# PyroSigma Series

Operator's Guide



The PyroSigma is a fixed-mount sensor for measuring the temperature of a surface without contact. Its extremely small size makes it ideal for installation where space is restricted.

The sensor works by detecting infrared energy that is emitted by the target object. The temperature is shown on the sensor's built-in OLED display, and can be monitored continuously via the DC voltage output, e.g. with industrial process instrumentation. The sensor also has a configurable alarm output.

## SPECIFICATIONS

General	
Measurement Temperature Range	0 to 1000°C
Analogue Output	Selectable 0-5, 1-5 or 0-10 V DC, linear with measured temperature
Alarm Output	Open collector with adjustable temperature threshold and hysteresis
Field of View	15:1 divergent optics (see OPTICS)
Accuracy	± 1.5% of reading or ± 1.5°C, whichever is greater
Repeatability	± 0.5% of reading or ± 0.5°C, whichever is greater
Response Time	250 ms
Configuration	Via built-in display and controls
Emissivity Setting	Adjustable 0.2 to 1.0
Max Temperature Span (Linear Output)	1000°C
Min Temperature Span (Linear Output)	100°C
Spectral Range	8-14 µm
Supply Voltage	24 V DC (max. 28 V DC)
Min. Supply Voltage (at Sensor)	12 V DC (for 0-10 V output) 6 V DC (for 0-5 V or 1-5 V output)
Max Current Draw (Sensor)	10 mA
Open Collector Alarm Output	6 to 24 V DC, 50 mA max (see Electrical Installation)

Environmental & Conformity	
Environmental Rating	IP65
Ambient Temperature Range	0°C to 70°C
Relative Humidity	95% max. non-condensing
Electromagnetic Compatibility (EMC)	EN61326-1, EN61326-2-3 (Electrical Equipment for Measurement, Control and Laboratory Use - EMC Requirements - Industrial)
RoHS Compliant	Yes

Configuration	
Configurable Parameters	Linear voltage output type and temperature range Alarm output threshold and hysteresis Emissivity setting Reflected temperature (e.g. for measuring a target in an oven or furnace)
Temperature Units	°C / °F

Mechanical	
Construction	Black anodised aluminium and blue ABS
Cable Length	1 metre standard (longer lengths available to order)
Weight with 1 Metre Cable	65 g

## ACCESSORIES

Accessories may be ordered at any time and added on-site. The following accessories are available:

Fixed mounting bracket - Adjustable mounting bracket - Air purge collar

## OPTIONS

Options are factory-installed and cannot be retrofitted. The following options are available:  
Certificate of Calibration - Extended cable

## INSTALLATION

The installation process consists of the following stages:

Preparation - Mechanical installation - Electrical installation

Please read the following sections thoroughly before proceeding with the installation.

## PREPARATION

Ensure that the sensor is positioned so that it is focused on the target only.

## OPTICS

The sensor measures the average temperature within a spot. The size of this spot depends on the distance between the sensor and the target surface.

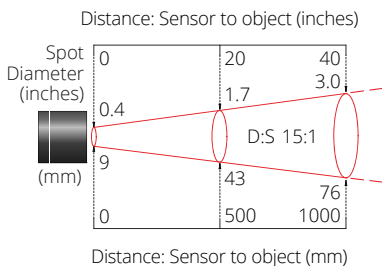

The sensor may be used at longer distances than shown, and will measure a larger spot. The measurement accuracy is not affected by the measurement distance.

There is no maximum measurement distance, provided the air between the sensor and target is free of obstructions.

## DISTANCE AND SPOT SIZE

Mount the sensor at a distance where the measured spot size is smaller than the target.

The spot size must not be larger than the target.

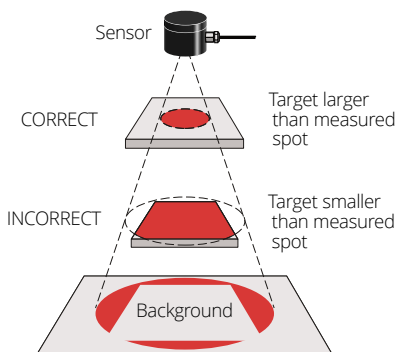

We normally recommend that the target should be at least twice the size of the measured spot for maximum accuracy.

## AMBIENT TEMPERATURE

The sensor is designed to operate in ambient temperatures from 0°C to 70°C.

Avoid thermal shock. Allow 20 minutes for the unit to adjust to large changes in ambient temperature.

## ATMOSPHERIC QUALITY

Smoke, fumes, dust and steam can contaminate the lens and cause errors in temperature measurement. In these types of environment, the air purge collar should be used to help keep the lens clean.

## ELECTRICAL INTERFERENCE

To minimise electromagnetic interference or 'noise', the sensor should be mounted away from motors, generators and such like.

## CABLE LENGTH

Check the length of the cable run between the sensor and the measurement instrumentation. If necessary, the sensor can be ordered with a longer cable attached.

Also, the cable can be extended using a shielded cable with 4 or more cores (3 if the alarm output is not used). Ensure the shield is also extended.

## MECHANICAL INSTALLATION

All sensors come with a 1 metre cable and two mounting screws. The sensor can be mounted on brackets or cut-outs of your own design, or you can use the fixed and adjustable mounting bracket accessories which are shown below.

The supplied mounting screws are for use with a panel or bracket at least 2 mm thick. The screws are 8 mm long.

Between the mounting holes, there must be a hole to allow the sensor a clear view through the panel or bracket. This hole must be larger than the lens of the sensor or the aperture of the air purge, if used. Use as large a hole as possible. Ensure the mounting does not obstruct the sensor's field of view (FOV); refer to the optical diagram in Specifications and allow a clear area twice the size of the FOV cone for maximum accuracy.

Note: The sensor must be grounded at only one point, either the cable shield or the mounting screws, but not both.

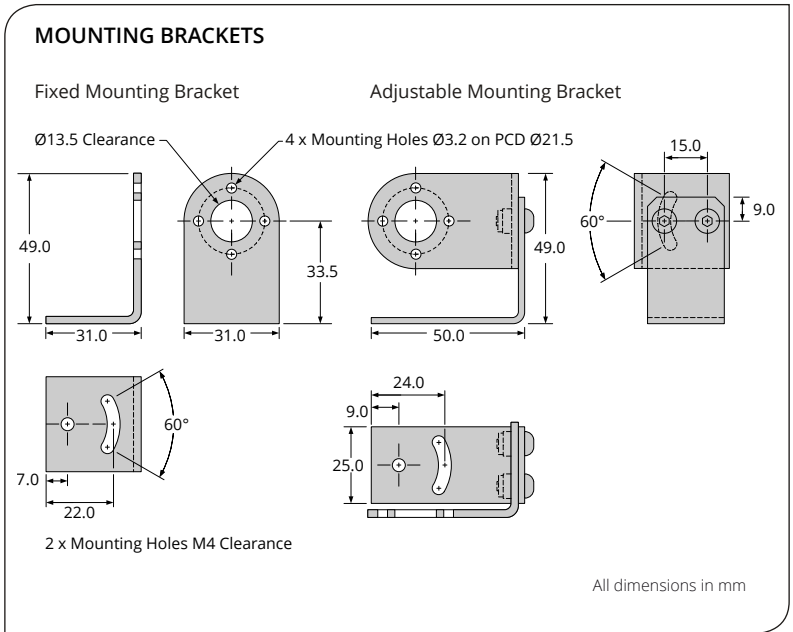

## AIR PURGE COLLAR

The air purge collar is used to keep dust, fumes, moisture, and other contaminants away from the lens. It fits between the sensor and the mounting surface. Longer screws are provided for use with a panel or bracket at least 2 mm thick.

Air flows into the hose barb fitting and out of the front aperture. Air flow should be 5 to 15 litres/min.

Clean or 'instrument' air is recommended.

### DIMENSIONS

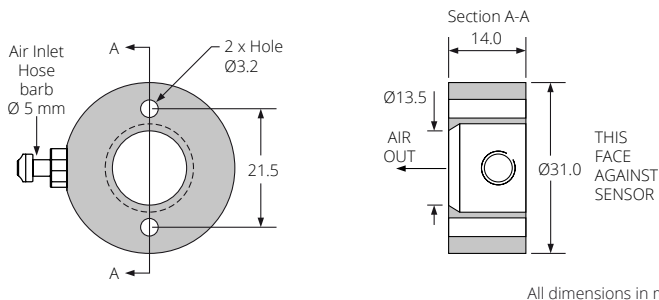

### INSTALLATION

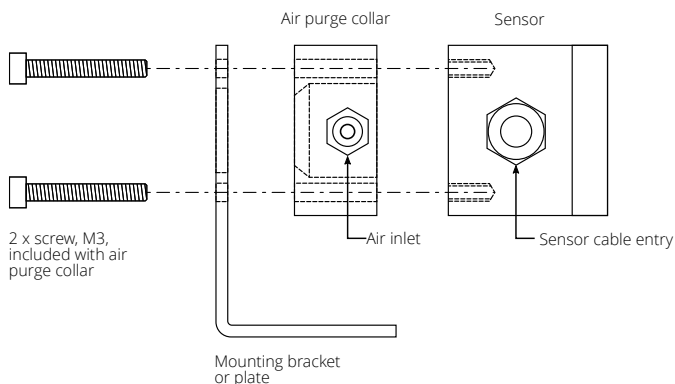

## ELECTRICAL INSTALLATION / DIMENSIONS

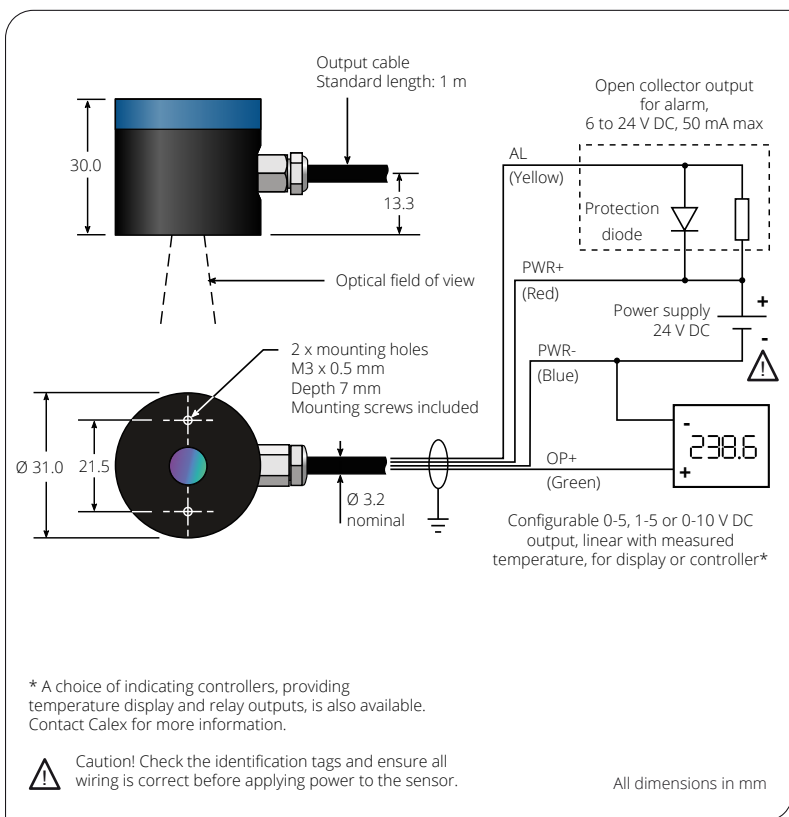

### POWER SUPPLY

Use a 24 V DC power supply.

Connect power between the PWR+ and PWR- wires. Do not apply voltage to the incorrect wires as this will damage the sensor. See "Dimensions and Connections" for wiring.

**IMPORTANT:** Ensure the power supply is only connected to the PWR+ and PWR- wires, and the polarity is correct, before switching the power on.

Ensure the supply voltage is suitable for the selected output type. For the 0-10 V DC output, the supply voltage must be 12 to 24 V DC.

Do not switch the power off and on again quickly. If the power is switched off, allow 15 seconds before switching it back on.

If using the alarm output, choose a load that draws no more than 50 mA when powered from 1.2 to 24 V DC. For example, if the alarm supply voltage is 24 V DC, ensure the load is at least 480 Ω ( $24 \text{ V} / 0.05 \text{ A} = 480 \Omega$ ).

## OUTPUT

The temperature output is a voltage signal, measured between OP+ and PWR-. The output voltage is linear with measured temperature. The output voltage range is configurable in the sensor's Settings menu.

## GROUNDING

The sensor is tested to industrial standards for electromagnetic compatibility (EMC) as shown in Specifications. For maximum protection against electromagnetic interference, the sensor must be connected to earth at one point, either the cable shield termination or the metal sensor housing, but not both.

To minimise electromagnetic interference or "noise", the sensor should be mounted away from sources of electromagnetic interference such as motors and generators.

## OPERATION

Once the sensor is in position and the appropriate power, air and cable connections are secure, the system is ready for continuous operation by completing the following simple steps:

- Turn on the power supply
- Turn on the connected measurement instrument
- Read / monitor the temperature

## DISPLAY / CONTROLS

OLED display: 64 x 48 pixels

Type of displayed temperature:

- RAW** Unfiltered measured temperature
- AVG** Measured temperature with averaging
- FIL** Measured temperature with averaging and peak/valley hold processing

Lock icon  
(to change settings, unlock sensor)

Temperature units (°C / °F)

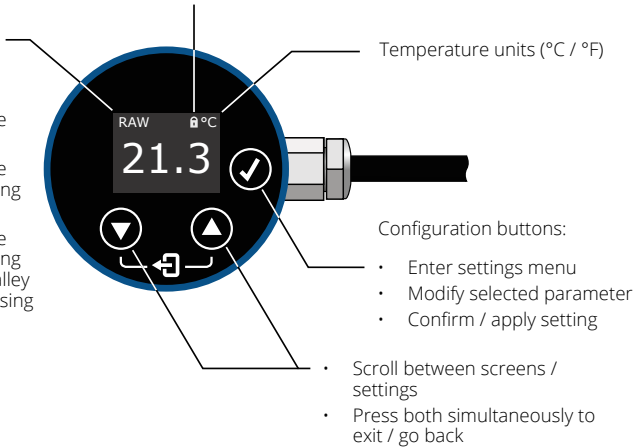

## CONFIGURATION

Menu	Setting	Description
Emissivity	Emissivity Setting	<p>Enter the emissivity setting (between 0.2 and 1.0). The emissivity setting should match the emissivity of the target surface. This can be determined experimentally by comparing measurements with a trusted contact probe, or estimated using an emissivity table.</p> <p>Non-reflective non-metals, such as rubber, foods, thick plastics, organic materials and painted surfaces, generally have a high emissivity, around 0.95. This is the default setting.</p> <p>Bare, clean metal surfaces can have a very low emissivity, and are often difficult to measure accurately. If possible, a measurable area of the surface should be painted or coated to reduce reflections and increase the emissivity.</p>
	Reflected Energy / Reflected Temperature	<p>In most applications, the target surface has the same surroundings as the sensor (for example, it is in the same room). In this case, Reflected Energy Compensation should remain Disabled for an accurate measurement. This is the default setting.</p> <p>However, if the sensor is positioned outside an oven or furnace, with the target object inside, the reflection of the hot furnace interior can affect the measurement. In this case, Reflected Energy Compensation should be Enabled and Reflected Temperature should be set to the temperature inside the oven or furnace.</p>
Filtering	Filtering settings are applied to the sensor's voltage and alarm outputs. They are optionally applied to the temperature display too (see Settings - Display).	
	Average Period	To slow the response time of the sensor, or to reduce fluctuations or noise on the measurement, enter an averaging period (in seconds) here.
	Hold Mode / Hold Period	If required, hold processing can be applied by setting Hold Mode to "Peak" or "Valley" and setting the hold period (in seconds). This is useful if the temperature reading is interrupted by gaps between moving objects, or by an obstruction.
Voltage Output	Set the temperature limits for the voltage output, and the output voltage range (choose from 0-5, 1-5 or 0-10 V DC).	
Alarm Output	Set Point	The temperature at which the alarm will be triggered. The display flashes while the alarm is triggered.
	Hysteresis	In Auto Reset mode, this is the temperature difference between the Set Point and the reset level.
	Reset Mode	<p>Manual: Press any button to acknowledge the alarm and deactivate the alarm output. The display keeps flashing until the alarm is reset. To reset the alarm, go to Settings Reset Alarm.</p> <p>Auto: The alarm will be reset automatically when the temperature passes the reset level.</p>

Menu	Setting	Description
Alarm Output (continued)	Alarm Trigger	<p>HI: The alarm is triggered if the temperature is higher than the Set Point.</p> <p>LO: The alarm is triggered if the temperature is lower than the Set Point.</p>
	Output Mode	<p>Active HI: In an alarm condition, the alarm wire AL will sink current to ground through the attached load (e.g. a relay).</p> <p>Active LO: In a non-alarm condition, the alarm wire AL will sink current as above.</p>
	Temperature Reference	<p>Measured: The temperature of the target object.</p> <p>Internal: The temperature inside the housing of the sensor. This can be used to indicate the ambient temperature where the sensor is mounted.</p>
Display	Displayed Temperature	<p>RAW: Measured temperature without averaging or hold processing</p> <p>FIL: Includes averaging and hold processing</p> <p>AVG: Includes averaging only</p> <p>This setting does not affect the sensor's outputs.</p>
	Temperature Units	Select Celsius or Fahrenheit. Units are changed throughout the sensor's interface.
	Screen Saver	If enabled, the sensor's display turns itself off after 1 minute of inactivity. Press any key to turn the display on again. The display will still turn on and flash if the alarm is triggered.
	Rotation	Change this setting from "Normal" to "Inverted" to make the display easy to read if the sensor is installed upside-down.
Reset Alarm	In Manual Reset Mode, after the alarm has been triggered and acknowledged, this function allows the alarm to be triggered again.	
Enter PIN / Lock Sensor	Enter the PIN to unlock the sensor and change the settings. The PIN is 1234. When configuration is complete, lock the settings again by selecting Lock Sensor.	

## **IMPORTANT**

Be aware of the following when using the sensor:

- If the sensor is exposed to significant changes in ambient temperature (hot to cold, or cold to hot), allow 20 minutes for the temperature to stabilise before taking or recording measurements.
- Do not operate the sensor near strong electromagnetic fields (e.g. around arc welders or induction heaters). Electromagnetic interference can cause measurement errors.
- Wires must be connected only to the correct terminals. Check all connections before applying power.
- Do not damage the cable, as this could provide a path for moisture and vapour into the sensor.
- Ensure the sensor is grounded at one point: either the cable shield termination, or the mounting screws, but not both.
- When the power is switched off, allow at least 15 seconds before switching the power back on.

## **LENS CLEANING**

Keep the lens clean at all times. Any foreign matter on the lens would affect measurement accuracy. Blow off loose particles (if not using the air purge accessory) with an air 'puffer'.

## **MAINTENANCE**

Our customer service representatives are available for application assistance, calibration, repair, and solutions to specific problems. Contact our Service Department before returning any equipment. In many cases, problems can be solved over the telephone. If the sensor is not performing as it should, try to match the symptom below to the problem. If the table does not help, call Calex for further advice.

## TROUBLESHOOTING

Symptom	Probable Cause	Solution
No output or display	No power to the sensor	Check the power supply and wiring
Inaccurate measured temperature	Target too small for sensor's field of view	Ensure the sensor's view is completely filled by the target. Position the sensor closer to the target to measure a smaller area.
	Incorrect emissivity setting	Choose the correct emissivity setting for the target material. See "Configuration - Emissivity" for more information.
	Target is a reflective metal surface	Try using a low emissivity setting, or paint or coat a measurable area of the target to make it non-reflective
	Field of view obstruction	Remove obstruction; ensure sensor has a clear view of target
	Dust or condensation on lens	Ensure lens is clean and dry. Clean gently with a soft lens cloth and water. If problem recurs, consider using an air purge collar.
Voltage output does not match displayed temperature	Output temperature scale mismatch	Check the output range and scale in Voltage Output settings; ensure the output scale matches the input range of the measurement instrument
No alarm output	Incorrect wiring or configuration	Check electrical connections (see Installation), Reset Alarm, and Alarm Output settings
Cannot change settings	Sensor is locked (padlock icon is displayed)	Go to Settings – Enter PIN to unlock the sensor

## DEFAULT SETTINGS

The sensor is fully configurable via the display and controls. No configuration is necessary in many applications: the sensor will work straight out of the box with the below default settings.

All settings are adjustable except those marked (fixed).

Setting	Range of Values	Default Value
Output Voltage	0-5 V / 1-5 V / 0-10 V	0-10 V
Temperature Low	0°C to 900°C	0°C
Temperature High	100°C to 1000°C	1000°C
Alarm Trigger	HI / LO / Off	HI
Temperature Reference (Alarm)	Measured / Internal	Measured
Alarm Set Point	0°C to 1000°C	100°C
Alarm Hysteresis	0°C to 30°C	1°C
Output Mode (Alarm)	Active HI / Active LO	Active HI
Alarm Reset	Auto / Manual	Auto
Emissivity Setting	0.2 to 1.0	0.95
Reflected Energy Compensation	On/Off	Off
Reflected Temperature	0°C to 1000°C	25°C (note: this value is automatically overridden when Reflected Energy Compensation is Off)
Averaging Period	0 s to 60 s	0 s
Hold Mode	Peak/Valley/Off	Off
Hold Period	0 s to 1200 s	0 s
Displayed Temperature	RAW / FIL / AVG	RAW
Temperature Units	°C / °F	°C
PIN		1234 (fixed)

## GUARANTEE

Calex guarantees each instrument it manufactures to be free from defect in material and workmanship under normal use and service for the period of two years from the date of purchase. This guarantee extends only to the original buyer according to Calex's standard Terms and Conditions of Sale.

Issue B - Oct 2023

---

### Calex Electronics Limited

PO Box 2, Leighton Buzzard, Bedfordshire, England LU7 4AZ

Tel: +44 (0)1525 373178 | mail@calex.co.uk | www.calex.co.uk