

File formats for customer logos on dials

WIKA data sheet IN 00.51

Technology

WIKA uses the latest technologies to custom print pressure gauge and thermometer dials. The high-quality printing features excellent UV resistance for long-lasting optimal readability of the measuring instruments.

The scale is defined using a specifically developed software tool and then drawn automatically using CAD software.

Trademark with customer logo

In pointer gauges, the dial is the component that permits the greatest variance for individual customer specifications. Since the dial is the focus of any measurement, WIKA is happy to fulfil the wish of many customers to have their own brand logo printed onto it.

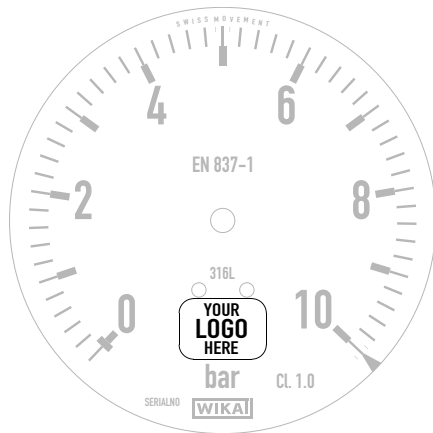

Example of dial with customer logo

Requirements for the logo file

File format

For optimal representation of logos, they should be supplied in a vector format, as this allows scaling without losses.

Vector formats (preferred)

File type	Description
EPS / PS	Encapsulated Postscript / Postscript
AI	Adobe Illustrator
CDR	Corel Draw
DWG	Autodesk AutoCAD
DXF	Drawing Interchange File Format

Bitmap formats (if vector format not available)

File type	Description
TIFF / TIF	Tagged Image File Format
PNG	Portable Network Graphics
JPG / JPEG	Joint Photographic Experts Group

Size for bitmap formats

At least 1,200 pixels, width or height

Colour specifications

- Full-tone colours (RAL or Pantone)
- Colour space (CMYK or sRGB)

In the event that there is no colour specification, the correctness of custom colours cannot be guaranteed. Files in bitmap format are vectorised for further processing.

Data administration

For the correct processing of the logo file, it must be stated whether it replaces an existing logo. Ideally, the customer logo should be transmitted to the sales team contact via the [questionnaire](#) in the download area of the WIKA website.

© 07/2021 WIKA Alexander Wiegand SE & Co. KG, all rights reserved.
The specifications given in this document represent the state of engineering at the time of publishing.
We reserve the right to make modifications to the specifications and materials.



WIKA Alexander Wiegand SE & Co. KG
Alexander-Wiegand-Straße 30
63911 Klingenberg/Germany
Tel. +49 9372 132-0
info@wika.de
www.wika.de

Notes on equipment protection per IEC/EN 60529 and NEMA For Bourdon tube or diaphragm pressure gauges

WIKA data sheet IN 00.18

General information

This technical information describes the measures to prevent both the formation of condensation within a hermetically sealed case, and also the intrusion of water into cases vented to the atmosphere. These measures apply both to Bourdon tube pressure gauges and to diaphragm pressure gauges.

1. Introduction and explanation of physical conditions

The formation of condensation in the cases of hermetically sealed, unfilled instruments cannot generally be avoided. This is based on the physical fact that the humidity found in air, under particular conditions, settles on cold surfaces as condensation. The warmer the air, the more humidity it can hold. If the air cools (e.g. at the window of a measuring instru-

ment), then the air can only hold a small amount of humidity. The excess humidity settles as condensation on the window.

In addition, water in the form of splash, jet and rain water from outside can intrude into the case, so long as the instrument is vented to atmosphere.

2. Explanation of the degrees of protection per IEC/EN 60529

Degrees of protection against solid foreign bodies, defined by the first index number

First index number	Degree of protection	
	Code designation	Definition
0	Not protected	–
1	Protected against solid foreign bodies of 50 mm diameter and larger	The object probe, a round body of 50 mm diameter, must not fully intrude ¹⁾
2	Protected against solid foreign bodies of 12.5 mm diameter and larger	The object probe, a round body of 12.5 mm diameter, must not fully intrude ¹⁾
3	Protected against solid foreign bodies of 2.5 mm diameter and larger	The object probe, 2.5 mm in diameter, must not intrude at all ¹⁾
4	Protected against solid foreign bodies of 1.0 mm diameter and larger	The object probe, 1.0 mm in diameter, must not intrude at all ¹⁾
5	Dust protected	Ingress of dust is not completely prevented, but dust may not intrude in a such a quantity that the satisfactory operation of the instrument or safety is impaired
6	Dust-proof	No ingress of dust

¹⁾ The full diameter of the object probe must not pass through any opening in the case.

Illustration 1

Source: IEC/EN 60529

Degrees of protection against water, defined by the second index number

Second index number	Degree of protection	
	Code designation	Definition
0	Not protected	–
1	Protected against dripping water	Perpendicularly falling drops must have no damaging effects.
2	Protected against dripping water when the case is inclined to 15°.	Perpendicularly falling drops must have no damaging effects, when the case is inclined to an angle of up to 15°, either side of perpendicular.
3	Protected against sprayed water	Water that is sprayed at an angle of up to 60°, either side of perpendicular, must have no damaging effects.
4	Protected against splash water	Water that splashes against the case from any direction must have no damaging effects.
5	Protected against water jets	Water that splashes against the case, as a jet, from any direction, must have no damaging effects.
6	Protected against strong water jets	Water that splashes against the case, as a strong jet, from any direction, must have no damaging effects.
7	Protected against the effects of temporary immersion in water	Water must not enter in any quantity which could cause damage, when the case, under standardised pressure and temperature conditions, is temporarily immersed in water.
8	Protected against the effects of permanent immersion in water	Water must not enter in any quantity which could cause damage, when the case is permanently immersed in water, under conditions which must be agreed between the manufacturer and user. The conditions must, however, be more demanding than those for the index number 7.

Illustration 2

Source: IEC/EN 60529

Example: Ingress protection IP65

- First index number 6: Dust-proof, no ingress of dust
- Second index number 5: Protected against water jets: Water that splashes against the case as a jet from any direction must have no damaging effects.

3. Comparison of NEMA (National Electrical Manufacturers Association) and IEC/EN 60529

NEMA ingress protection Model number	IEC/EN 60529 ingress protection Classification
1	IP10
2	IP11
3	IP54
3 R	IP14
3 S	IP54
4 and 4 X	IP66
5	IP52
6 and 6 P	IP67
12 and 12 K	IP52
13	IP54

Illustration 3

4. Measures against the formation of condensation

Different fill fluids depending on the ambient temperature and the electrical conductivity

In order to avoid the formation of condensation in the case, WIKA recommends filling the instruments with glycerine. For contact gauges, the filling can be made with silicone oil, since silicone oil, unlike glycerine, is not hygroscopic and therefore prevents a short-circuit within the instrument.

If the ambient temperature drops below $-20\text{ }^{\circ}\text{C}$, then we recommend that the instrument absolutely must be filled with silicone oil. Even at temperatures down to $-50\text{ }^{\circ}\text{C}$, silicone oil can still be used due to its low viscosity.

For flammable and/or explosive media, e.g. oxygen, inert fill fluids must be used.

5. Hermetically sealed instruments and effects associated with them

In order to prevent the intrusion of water into the case, it is recommended that an ingress protection method is chosen that reliably inhibits this (see illustrations 1 and 2). The ingress protection demands that the instrument is hermetically sealed.

With vented instruments, the vent valve has to be closed in order to achieve the specified ingress protection. This, however, produces a temperature error, which can affect the measuring result (see illustrations 4, 5 and 6). Therefore the vent valve has to be opened for a short time before reading the measured value.

5.1 Temperature errors in unfilled and filled Bourdon tube pressure gauges

A standard 232.50/30 instrument with a pressure range greater than 25 bar can be made hermetically sealed without any problems, and manufactured with an ingress protection of IP66. The temperature error that occurs with these instruments is negligible, since it is so small in relation to the pressure range, that the instrument still will operate within its specified class accuracy.

Instruments with a scale range of less than 25 bar can likewise be made hermetically sealed, though a temperature error will then be present (see illustration 4). The temperature errors present are shown in the following graphs.

Temperature errors in hermetically sealed, unfilled Bourdon tube pressure gauges

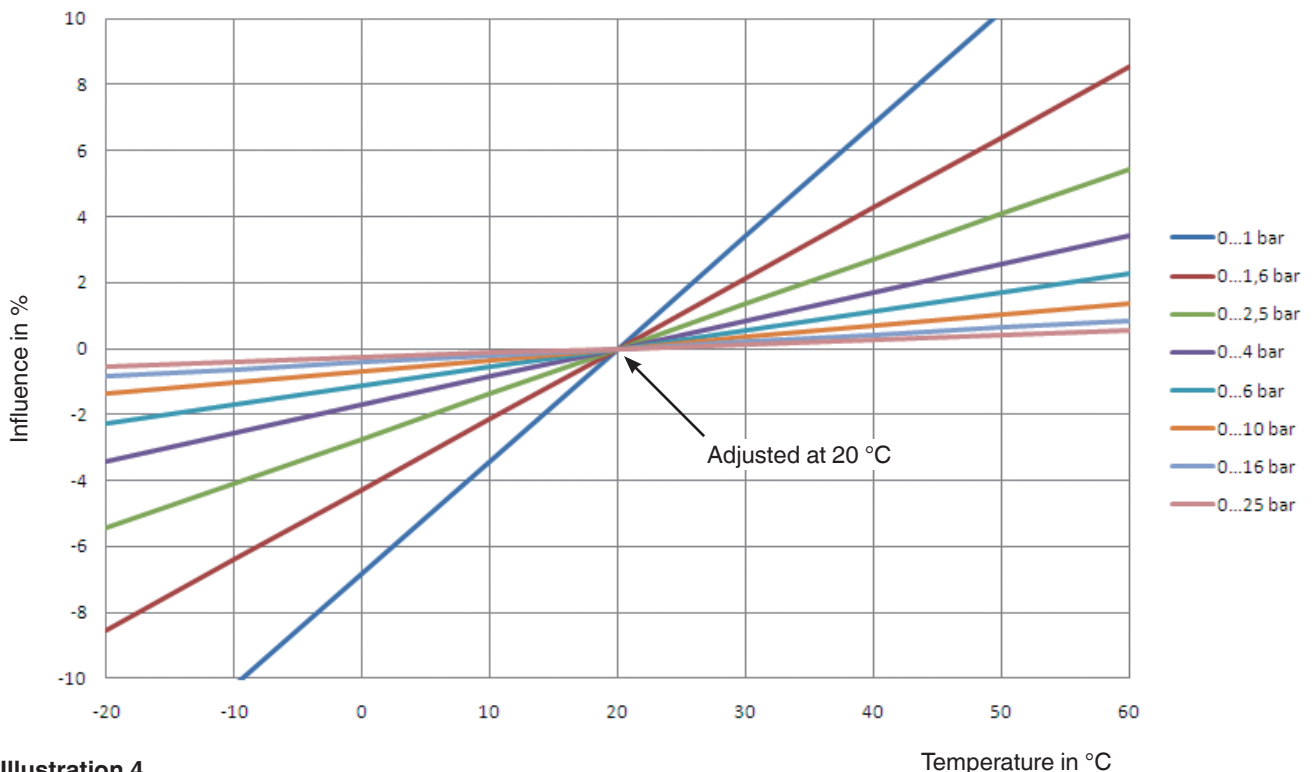

Illustration 4

Temperature in °C

Temperature errors in hermetically sealed, filled Bourdon tube pressure gauges

Filled to 90 % with glycerine

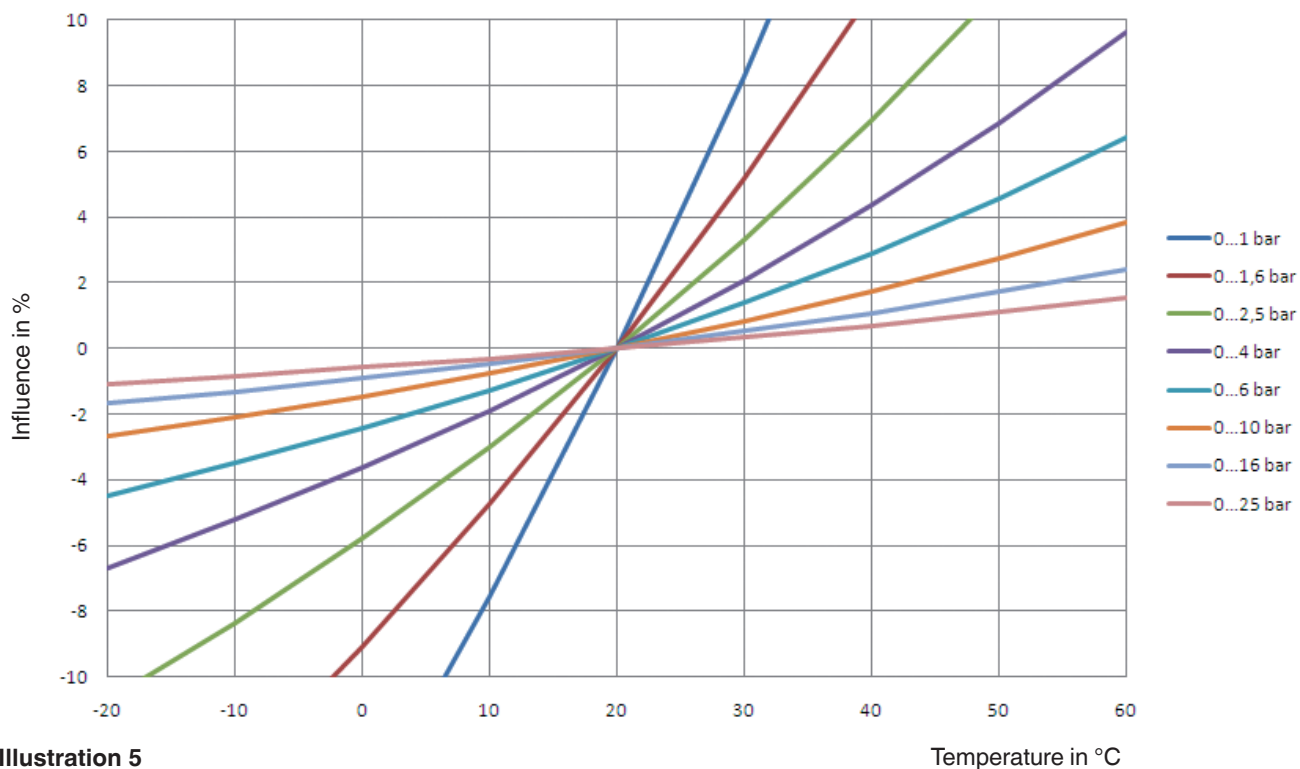

Illustration 5

Filled to 90 % with silicone oil

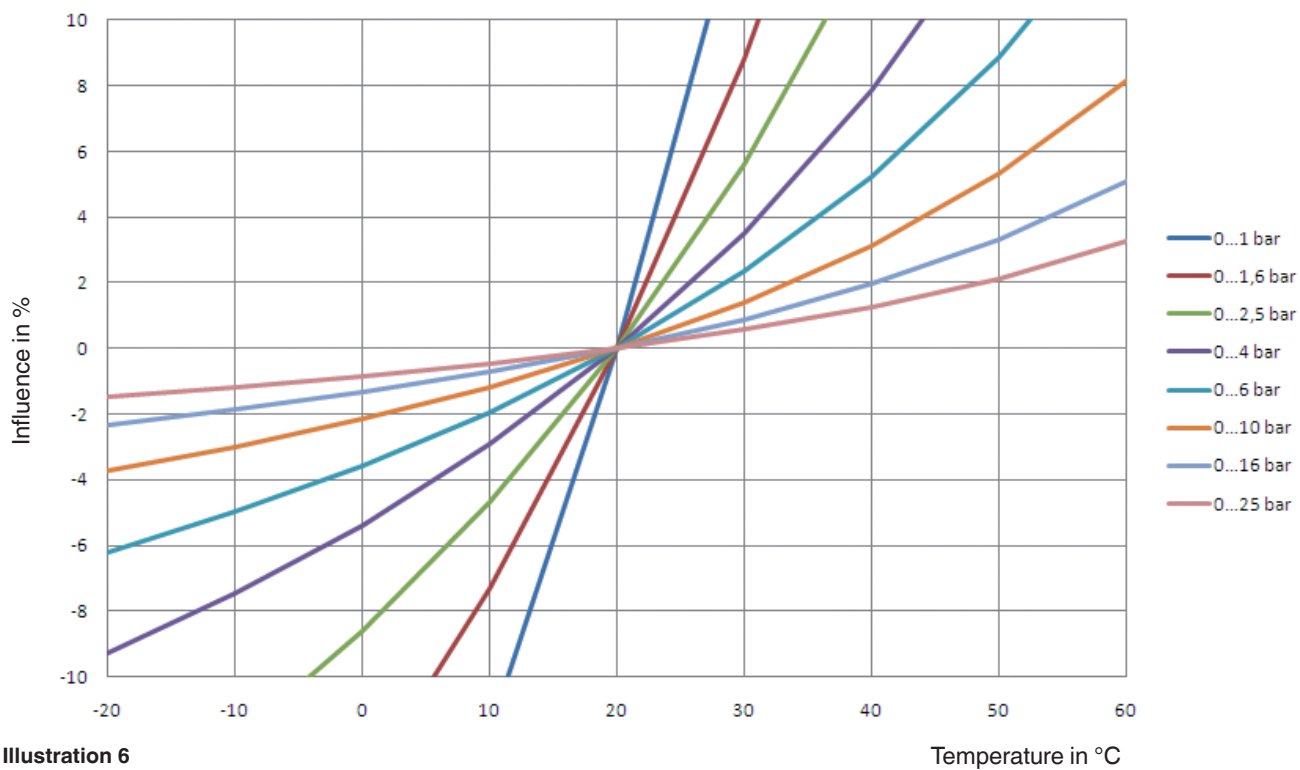

Illustration 6

5.1 Temperature errors in unfilled and filled diaphragm pressure gauges

With model 4, 5 and 7 hermetically sealed diaphragm pressure gauges, the temperature error for scale ranges ≥ 100 mbar is negligible. For scale ranges < 100 mbar we recommend only using instruments with a pressure compensating diaphragm.

For instrument models 7xx.14, DPG40, DPGS40, DPGS40TA, DPGT40, DPS40, 700.01/02 and 7x2.15, due to their mechanical design, there are no additional temperature errors.

5.3 Model overview

Pressure gauges for which the formation of condensation and the ingress of water from the outside can be prevented:

Influence	Bourdon tube pressure gauges					Diaphragm pressure gauges					
	Model 2 unfilled		Model 2 filled		Model 233.30 filled, with pressure compensating diaphragm	Model 4 and 7 unfilled		Model 4 and 7 filled		Model 4 and 7 unfilled, with pressure compensating diaphragm	Model 4 and 7 filled, with pressure compensating diaphragm
	≥ 25 bar	< 25 bar	≥ 25 bar	< 25 bar		≥ 25 bar	< 25 bar	> 100 mbar	< 100 mbar		
Formation of condensation	unavoidable		✓	✓	✓	unavoidable		✓	✓	unavoidable	✓
Hermetically sealed ¹⁾	Influence negligible	For influence see illustration 4	Influence negligible	For influence see illustration 5 or 6	✓	Influence negligible	Technically not solvable	Influence negligible	Technically not solvable	✓	✓

1) Hermetically sealed = air-tight case

Illustration 7

6. Pressure compensating diaphragm

As can be seen in illustration 7, formation of condensation in filled pressure gauges can be prevented by the use of pressure compensation diaphragms, without any temperature error. Pressure compensation diaphragms can be used for all safety pressure gauges per EN 837-1 S3.

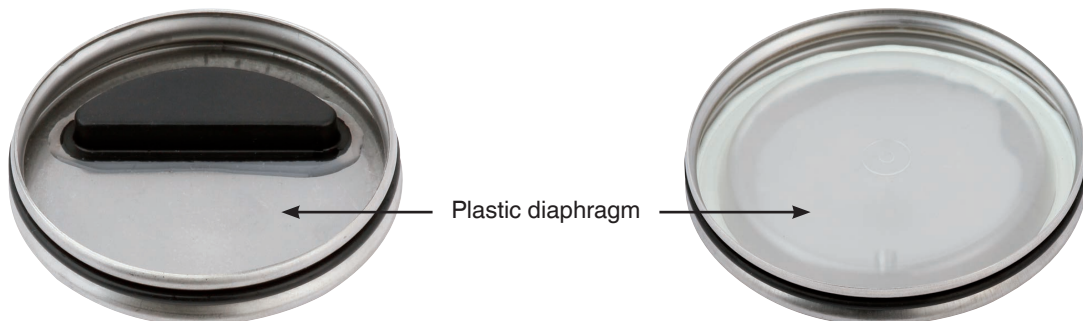

Illustration 8: Rear wall of case with pressure compensating diaphragm, nominal size 63

Illustration 9: Rear wall of case with pressure compensating diaphragm, nominal size 100

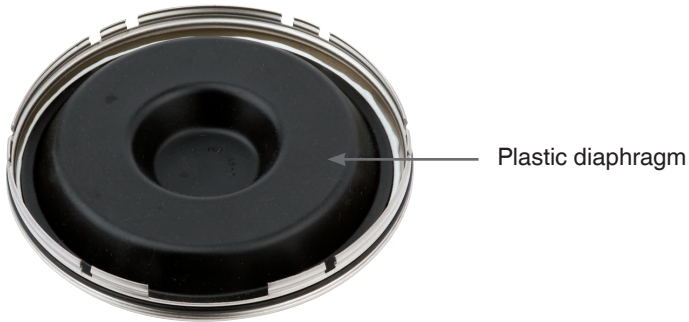

Illustration 10: Rear wall of case with pressure compensating diaphragm for contact gauges, nominal size 160

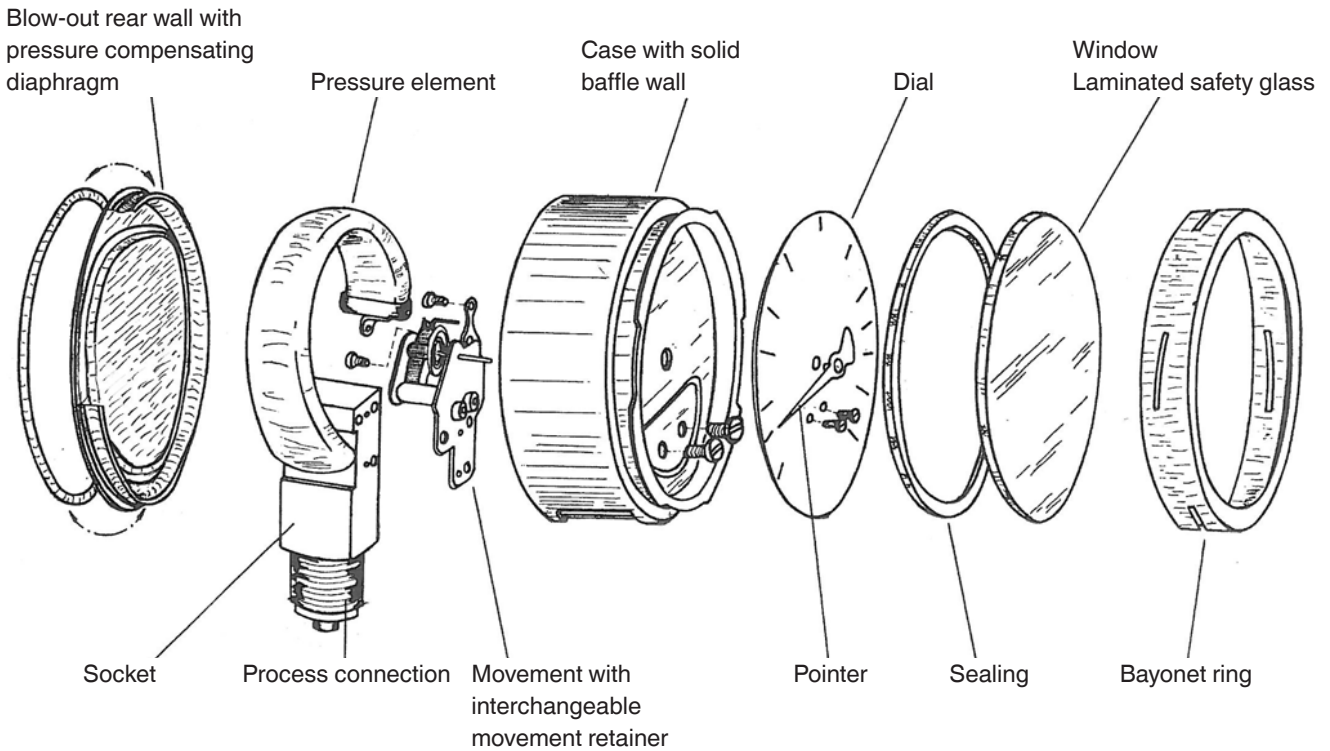

Illustration 11: Exploded view drawing

© 09/2010 WIKA Alexander Wiegand SE & Co. KG, all rights reserved.
 The specifications given in this document represent the state of engineering at the time of publishing.
 We reserve the right to make modifications to the specifications and materials.



WIKA standard documentation

WIKA data sheet IN 00.24

Requirements

Extensive processes require detailed documentation. For complex operations, data sheets and operating instructions are not sufficient anymore as documents accompanying the products.

Additional documents such as certificates, analyses or quality management procedures provide exact proof that the instruments are ideally suited for the particular application. In this way a detailed documentation conforming to the law contributes to plant safety.

WIKA standard documentation

The WIKA standard documentation complies with the legal conditions of acceptance (in paper format and/or as a navigable CD-ROM).

Our individual documents are constantly updated. They are subject to the “product lifecycle” (further development of the existing product). A unique attribution of the documents to the production order at the time of manufacture is ensured. WIKA provides these documents in many languages and in the desired quantity.

Customer-specific designs

Of course we can also provide the documentation according to your requirements:

- Customer logo
- Cover sheet layout
- Ring binders
- Sequence
- Further documents



WIKA standard documentation

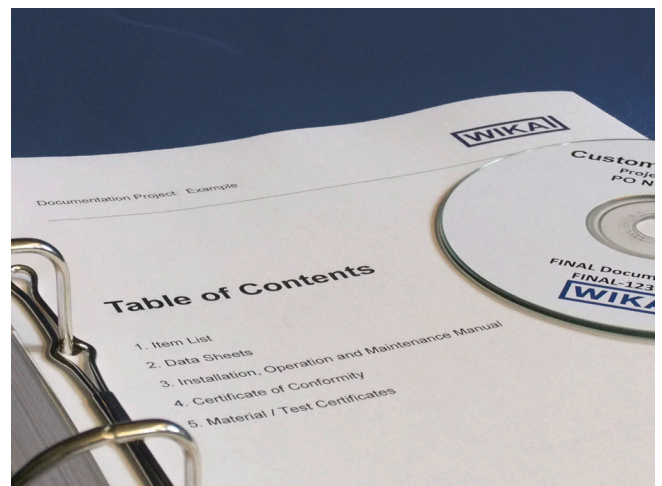

Table of Contents

WIKA standard documentation

This contains following documents:

Abbreviation	Description
TAG	Item list (Tag no. list)
CATL	Data sheets (catalogues)
IOM	Operating instructions (installation, operation and maintenance)
DOC	Declaration of conformity (EC, ATEX, EMC, PED)
ZGN	Certificates/Test reports
WFC	Wake frequency calculation (optional)
FLC	Flow calculation (optional)

These documents can be provided additionally:

Abbreviation	Description
DRWG	Drawings
QM	Quality management procedures
QT	Quality test procedures
CSP	Commissioning spare parts list
2SP	2 years spare parts list
NDE	Non-destructive examinations
SIP/RPP	Transport, packaging and storage instructions
MCOC	Manufacturer's certificates of compliance
PASS	Passport (import permit for instruments destined for Russia)

© 2013 WIKA Alexander Wiegand SE & Co. KG, all rights reserved.
The specifications given in this document represent the state of engineering at the time of publishing.
We reserve the right to make modifications to the specifications and materials.



Elastic element pressure gauges

WIKA data sheet IN 00.01

Description

Indicating pressure gauges with elastic measuring elements are used extensively to measure pressure in technical applications due to their robustness and ease-of-use. They incorporate measuring elements which deform elastically under the influence of pressure. Mechanical pressure gauges are produced with bourdon tube, diaphragm, capsule and spring elements and are differentiated as a result of these.

The measuring elements are made of copper alloys, alloyed steels or, for specific measuring applications, produced in special materials. Pressures are only measurable in combination with a reference pressure. Atmospheric pressure usually serves as the reference pressure, and the pressure gauge therefore shows how much the measured pressure is

higher or lower in relation to the given atmospheric pressure (i.e. an overpressure measuring instrument).

The pressure is indicated in standard measuring ranges over a 270 degree sweep on the dial. Liquid-filled pressure gauges, due to their damping effect, offer optimal protection against damage from high dynamic pressure loads or vibrations. By combination with limit signal indicators, switching can be carried out, while in combination with transmitters, electrical output signals (e.g. 4 ... 20 mA) can be used for industrial process automation.

Pressure gauges with bourdon tube

Bourdon tubes are circular-shaped tubes with an oval cross-section. The pressure of the media acts on the inside of this tube which results in the oval cross section becoming almost circular. Through the curvature of the tube, hoop stresses occur which bend the bourdon tube. The end of the tube, which is not fixed, moves, and this indicates the measurement for the pressure.

Through the pointer movement this motion is indicated on the display. The circular-shaped tubes, formed through an angle of approx. 250°, are used for pressures up to about 60 bar.

For higher pressures, bourdon tubes are used with either a number of superimposed coils of the same diameter (i.e. helical coils), or a spiral-shaped coil (i.e. spiral springs) in a single plane.

Bourdon tubes can only be protected against overload to a limited extent. In order to fulfil particularly harsh measuring tasks, the pressure gauge can be fitted with a chemical seal upstream as a separation or protection system.

The pressure ranges can be between 0 ... 0.6 and 0 ... 7000 bar with a reading accuracy (or class) from 0.1 to 4.0 %.

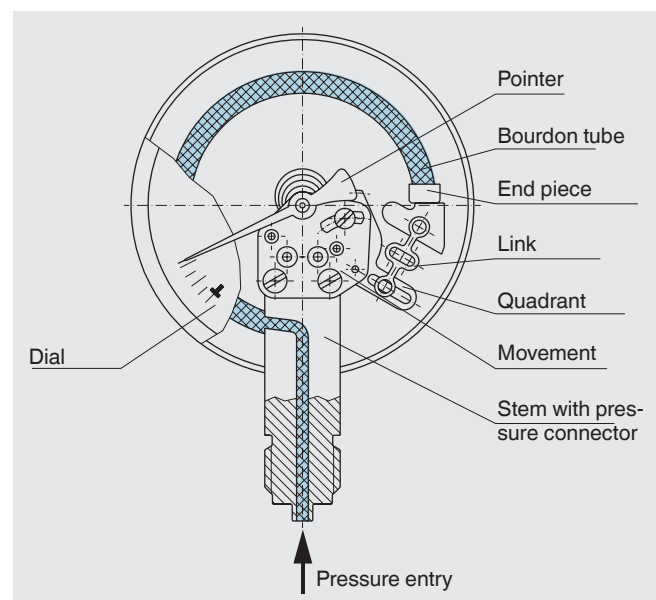

Fig. Pressure gauges with bourdon tube

Pressure gauges with diaphragm elements

Diaphragm elements are circular-shaped, corrugated membranes. They are either clamped around their rim between two flanges or welded and are subjected to the pressure of the media acting on one side. The deflection caused by this is used as a measurement for the pressure and is indicated by a pointer.

In comparison with bourdon tubes, these diaphragm elements have a relatively high actuating force and, as a result of the annular clamping of the element, they are insensitive to vibration.

The diaphragm element can be subject to higher overload through the load take-up (diaphragm element resting against the upper flange), and by coating it with special material or covering it with foil, the gauge can be protected against extremely corrosive media.

For measurements with highly viscous, impure or crystallizing media, wide connection ports, open connection flanges and purging capabilities can be integrated.

Pressure ranges can be between 0 ... 16 mbar and 0 ... 40 bar with accuracy classes from 0.6 to 2.5.

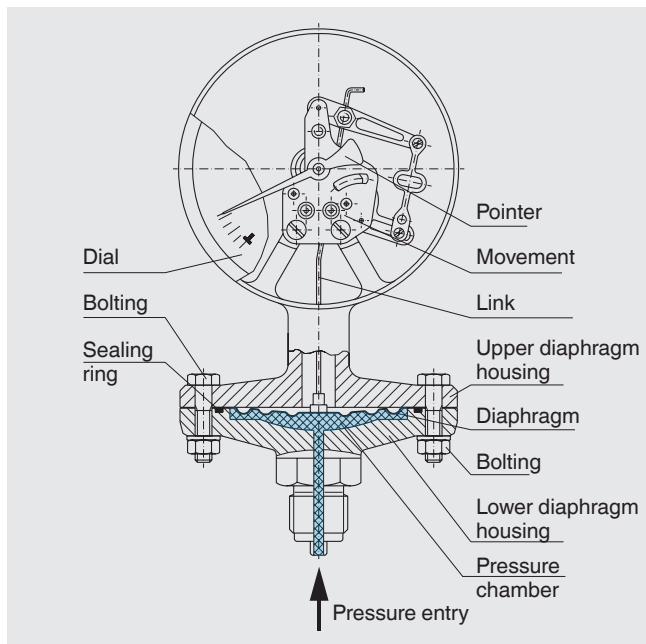

Fig. Pressure gauges with diaphragm elements

Pressure gauges with capsule elements

The capsule element comprises two circular-shaped, corrugated membranes fully-sealed around their circumference. The pressure acts on the inside of this capsule and the stroke movement generated is indicated by a pointer as the measurement of pressure.

Pressure gauges with capsule elements are particularly suited to gaseous media and relatively low pressures. Overload protection is possible within certain limits. The actuating force is increased if a number of capsule elements are connected mechanically in series (a capsule element "package").

Pressure ranges can be between 0 ... 2.5 mbar and 0 ... 0.6 bar with accuracy classes of 0.1 to 2.5.

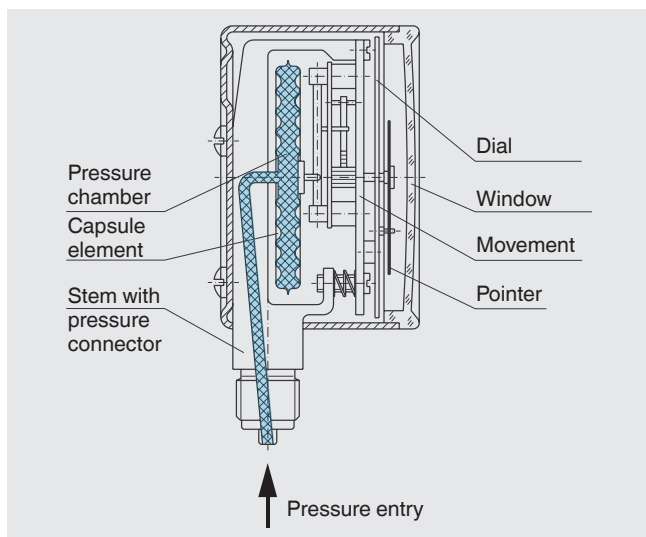

Fig. Pressure gauges with capsule elements

Absolute pressure gauges

These instruments are used where pressures are to be measured independently of the natural fluctuations in atmospheric pressure. As a general rule, all the previously shown overpressure gauge elements and measuring principles can be applied.

The pressure of the media to be measured is compared against a reference pressure which is equal to absolute zero. On the side of the measuring element that is not subjected to the pressure media, an absolute vacuum exists as the reference pressure. This function is achieved by sealing off the appropriate measuring chamber or surrounding housing.

Measuring element movement transmission and pressure indication are achieved in the same way as with the previously described overpressure gauges.

Pressure ranges can be between 0 ... 25 mbar and 0 ... 25 bar with accuracy classes of 0.6 to 2.5.

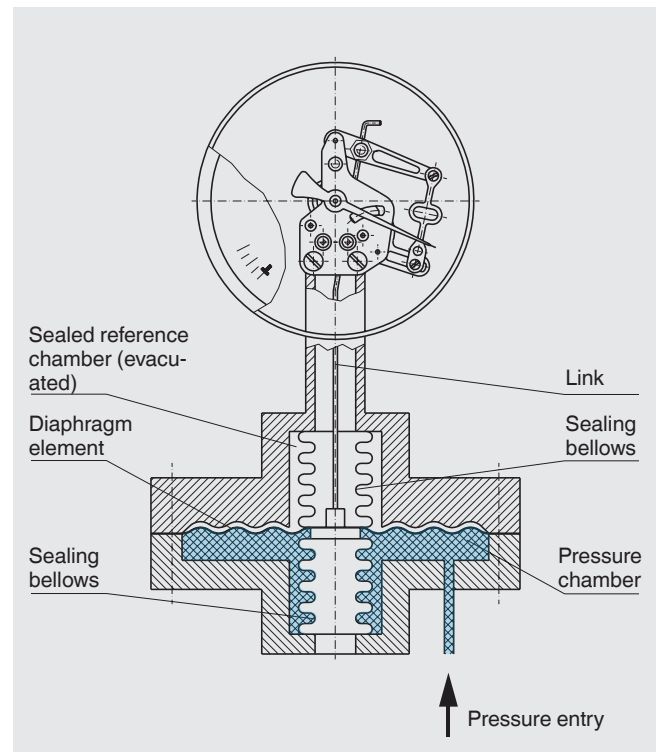

Fig. Absolute pressure gauges

Differential pressure gauges

With differential pressure gauges, the difference between two pressures is determined directly and shown on the display. Here again, all the previously shown overpressure gauge measuring elements and measuring principles can be applied.

Two sealed pressure media chambers are separated by the measuring element/s. If both operating pressures are the same, no movement of the measuring element occurs and no pressure will be indicated. A differential pressure reading is only given when one of the pressures is either higher or lower than the other.

Even with high static pressures, low differential pressures can be measured directly. With diaphragm elements, a very high overload capability is achieved.

The permissible static pressure and the overload capability on the \oplus and \ominus side must be observed.

In the majority of cases, measuring element movement transmission and pressure indication are achieved in the same way as with the previously described overpressure gauges.

Pressure ranges can be between 0 ... 16 mbar and 0 ... 40 bar with accuracy classes of 0.6 to 2.5.

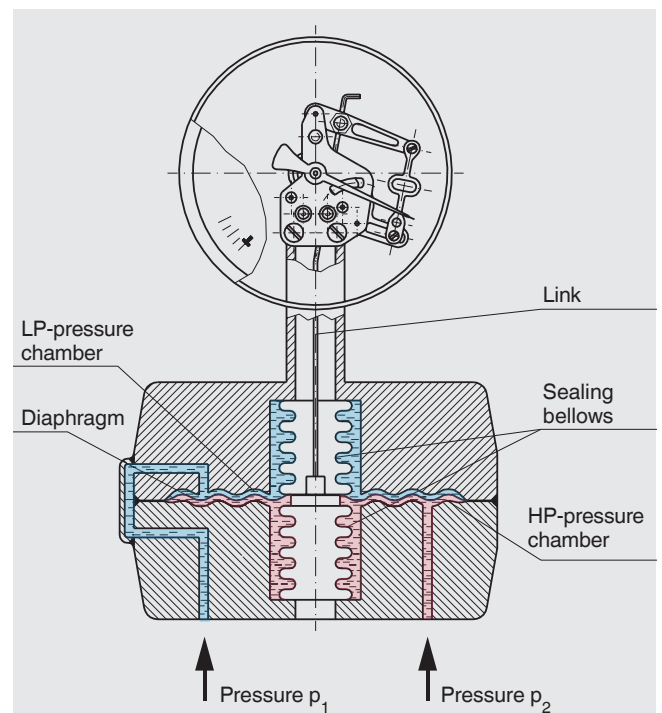

Fig. Differential pressure gauges

Applications

- Filter technology (monitoring filter state)
- Level measurement (in closed vessels)
- Flow measurement (pressure drop)

The specifications given in this document represent the state of engineering at the time of publishing.
We reserve the right to make modifications to the specifications and materials.



WIKAI Alexander Wiegand SE & Co. KG
Alexander-Wiegand-Straße 30
63911 Klingenberg/Germany
Tel. (+49) 9372/132-0
E-mail info@wika.de
www.wika.de

Information on process connections

WIKA data sheet IN 00.14

Applications

- For the definition of the process connections for WIKA pressure measuring instruments

Scope

- Pressure sensors
- Electronic pressure switches
- UHP transducer

Contents

- Mounting at the process connection
- Dimensions of the process connections
- Max. measuring ranges and overpressure limits depending on the process connections

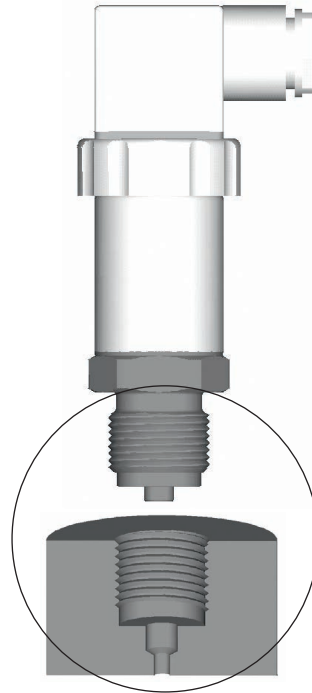

Description

WIKA offers pressure measuring instruments with a variety of process connections in order to meet diverse customer-specific application requirements.

Mounting

The following notes relate to process connections with specified geometric and functional features in accordance with technical regulations.

Requirements for the mounting point

The mounting point must meet the following conditions:

- Keep the sealing faces at the pressure sensor and the measuring location clean and free from scratches.
- Remove the protective cap and/or the Mylar or protective foil not until shortly before installation.
- Observe the permissible ambient temperatures. Do not exceed the performance limits of the measuring instrument specified by the manufacturer. Consider possible restrictions on the ambient temperature range due to the mating connectors used.

Mechanical mounting

Carry out the mounting in accordance with the following steps:

1. Prior to commissioning, subject the instrument to a visual inspection.
→ Leaking liquid is indicative of damage.
2. Depressurise the container, pipeline or system.
3. Ensure that the sealing faces are clean and do not show any mechanical damage.
4. Seal the sealing face, see [„Sealing variants“](#).
5. At the mounting point, screw the instrument in hand-tight.
→ Make sure not to cross the threads.
6. For force transmission, use only the defined spanner flats, see [„Spanner flats“](#).
→ The case must not be subjected to mechanical load. Never use the case as a working surface.
7. Tighten the instrument with a torque wrench using the spanner flats.



The correct torque depends on the mounting point (e.g. material and shape).

Only use the instrument if it is in perfect condition with respect to safety.

Only use original accessories. For accessories, see data sheet for the respective pressure sensor or pressure switch.

Spanner flats

To avoid damage to the instrument, always use the correct spanner flats.

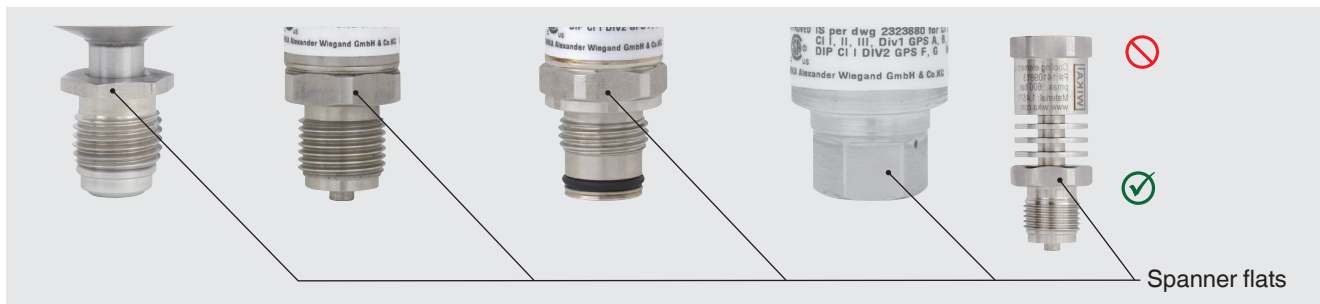

Sealing variants

To meet the diverse requirements and operating conditions in different applications, seal the process connections as follows:

Parallel threads

For sealing, use flat gaskets, lens-type sealing rings or WIKA profile sealings at the sealing face ①.

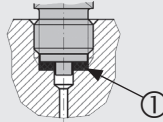

per EN 837

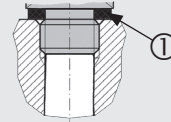

per DIN EN ISO 1179-2
(formerly DIN 3852-E)

Tapered threads

For sealing, the thread is wound with additional sealing material, e.g. PTFE tape.

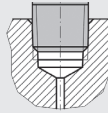

NPT, R and PT

→ For notes on seals, see WIKA data sheet AC 09.08 at www.wika.com.

Additional notes for special process connections

In certain applications, process connections with special geometric or functional properties are used. This section describes the relevant deviations, technical requirements and notes on the safe and compliant use of such connections.

Cooling element

Cooling elements must not be insulated.

The cooling elements are crucial for regulating the temperature of the pressure measuring instrument. Insulation would impede heat dissipation and could cause the instrument to overheat. This impairs the measurement accuracy and shortens the service life of the pressure measuring instrument.

Flush process connections

Diaphragms must be undamaged.

The diaphragm is the direct interface between the medium and the measuring instrument and is crucial for the following aspects:

- Measurement accuracy: An intact diaphragm ensures correct pressure transmission without errors.
- Prevention of blockages: Especially with viscous, crystalline or abrasive media, an undamaged diaphragm prevents blockages and damage to the pressure port.
- Protection of the measuring instrument: The diaphragm protects the measuring instrument from aggressive or adhesive media.
- Hygiene and cleaning: An undamaged diaphragm makes cleaning easier and prevents contamination, which is particularly important in hygienic applications.

Hygienic process connections

The following notes must be observed when using hygienic process connections:

- Never loosen sealed filling screws on the measuring instrument. Loosening of the filling screws can lead to leakage and contamination.
- For mounting, use the appropriate fastenings. In accordance with the fittings and flange standards, suitable screws, nuts or clamps must be used to ensure a secure and leak-tight connection.
- Only use seals with a sufficiently large inner diameter. The seal must be inserted centrally to prevent contact with the diaphragm, which could lead to measuring deviations.
- Position the welding socket correctly. Position the welding socket so that the bore for leakage detection points downwards. The nozzle must be welded flush with the inner wall of the vessel and ground smooth. The surface roughness of the ground surfaces must be $Ra \leq 0.8 \mu\text{m}$.
- Observe the seal manufacturer's instructions. When using soft or PTFE seals, observe the instructions of the seal manufacturer, particularly with regard to tightening torque and load cycles.

UHP process connections

The following notes must be observed when using UHP process connections:

- Complete the weld seam. The weld seam must be fully welded to ensure a secure and leak-tight connection.
- Observe the minimum current and heat input. To avoid damage, ensure that the current and heat input during the welding process are as low as possible.
- Cool the argon flow during the welding process. To improve the quality of the weld seam, cool the flow of argon during welding.
- Perform test welds in advance. Test welds help to prevent welding errors and improve the quality of the weld.
- Clean the connection components. Clean the connection components (such as cable glands, seals and connectors) with pure/filtered gas.



Observe the specifications and notes. Observe the specifications and notes of all components and manufacturers.

Note on VCR[®]-compatible connections

For VCR[®]-compatible connections, the union nut/male nut or fitting must be tightened beyond the hand-tight position (depending on the seals used) using a 1/8 or 1/4 turn. Excessive tightening can damage the sealing lips and lead to possible leakage. Do not scratch the sealing lips.

VCR[®] is a registered trademark of Swagelok

Notes on rework

The following rework steps are required for UHP products:

- Set the zero point. A zero point is required; see the operating instructions for the respective instrument.
- Check for leak tightness. Check the UHP connections (threaded connections, welds) for leak tightness using a suitable test (e.g. helium leak test).
- Check the gas flow. Switch the gas flow on and off at least 10 times to remove any particles that may have entered during installation. The flow rate of the gas should correspond to the subsequent process flow.

Dimensions in mm [in]

Threaded connections

DIN EN ISO 1179-2

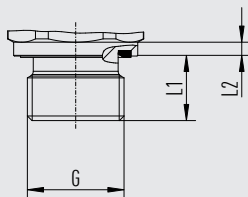

G	L1	L2
G 1/8 A	8 [0.31]	1.5 [0.059]
G 1/4 A	12 [0.47]	2 [0.08]
G 1/2 A	14 [0.55]	3 [0.12]

DIN EN ISO 9974-2

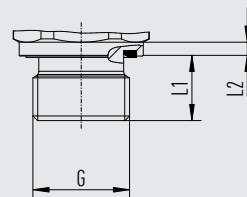

G	L1	L2
M10 x 1.0	8 [0.31]	1.5 [0.059]
M14 x 1.5	12 [0.47]	2 [0.08]

EN 837

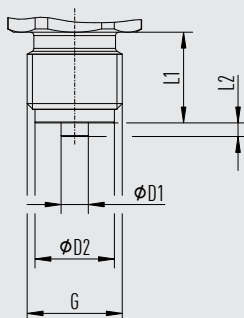

G	L1	L2	D1	D2
G 1/4 B	13 [0.51]	2 [0.08]	5 [0.19]	9.5 [0.374]
G 3/8 B	16 [0.63]	3 [0.12]	5.5 [0.22]	13 [0.512]
G 1/2 B	20 [0.79]	3 [0.12]	6 [0.24]	17.5 [0.689]

EN 837

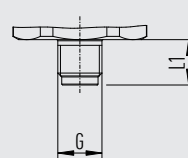

G	L1
G 1/8	10 [0.39]

ISO 6149-2

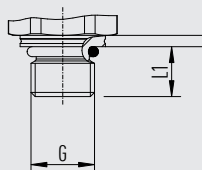

G	L1
M14 x 1.5	11 [0.43]

DIN 16288

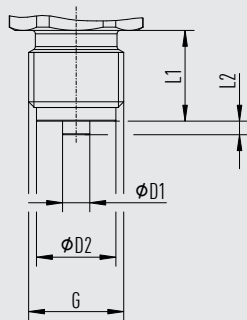

G	L1	L2	D1	D2
M12 x 1.5	13 [0.51]	2 [0.08]	5 [0.19]	9.5 [0.374]
M20 x 1.5	20 [0.79]	3 [0.12]	6 [0.24]	17.5 [0.689]

SAE J514, sealing cone

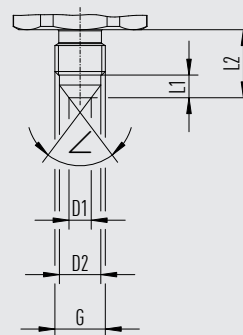

G	L1	L2	D1	D2	∠
7/16-20 UNF-2A	5 [0.2]	15 [0.59]	4.9 [0.193]	9.12 [0.359]	74°

SAE J514, O-ring BOSS

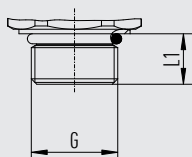

G	L1
3/4-16 UNF-2A, O-ring BOSS	11.13 [0.4382]

SAE J514, O-ring BOSS

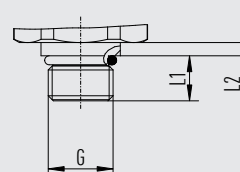

G	L1	L2
7/16-20 UNF-2A, O-ring BOSS	9.14 [0.3598]	2.92 [0.1149]
9/16-18 UNF-2A, O-ring BOSS	9.93 [0.3909]	2.92 [0.1149]

ANSI/ASME B1.20.1

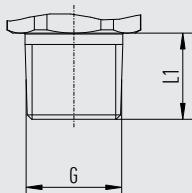

G	L1
1/8 NPT	10 [0.39]
1/4 NPT	13 [0.51]
1/2 NPT	19 [0.75]

KS B 0222

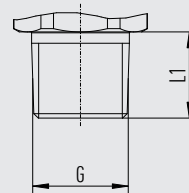

G	L1
PT 1/4	13 [0.51]
PT 3/8	15 [0.59]
PT 1/2	19 [0.75]

ISO 7

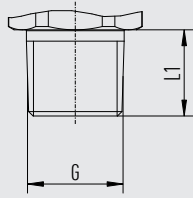

G	L1
R ¼	13 [0.51]
R ⅜	15 [0.59]
R ½	19 [0.75]

JIS B 7505-76

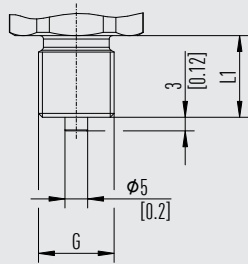

G	L
G ¼ B	16 [0.63]

JIS B 2351-1

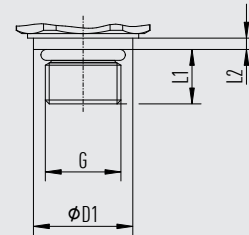

G	D1	L1	L2
G ¼ FORM O with collar	19 [0.75]	10 [0.39] ¹⁾	2 [0.08]
G ⅜ FORM O with collar	21.9 [0.962] ¹⁾	12 [0.47]	2.5 [0.098]

1) Not in accordance with standard

Connections with female thread

ANSI/ASME B1.20.1

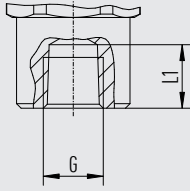

G	L1
¼ NPT	14 [0.55]

EN 837

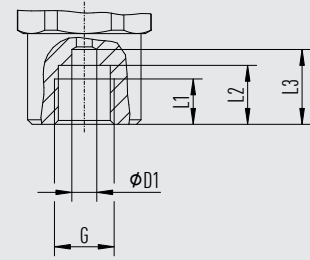

G	L1	L2	L3	D1
G ¼	10 [0.39]	13 [0.51]	16.5 [0.65]	5.5 [0.217]

ISO 8434-1

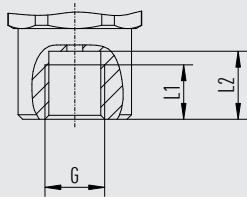

G	L1	L2
G ¼ (compatible with bite-type fittings)	12 [0.47]	15 [0.59]

Metric threads

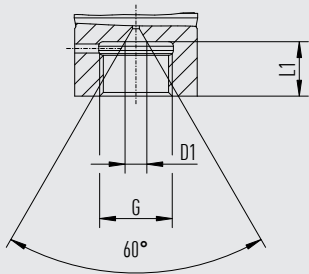

G	L1	D1
M16 x 1.5, with sealing cone	12 [0.47]	4.8 [0.189]
M20 x 1.5, with sealing cone	15 [0.59]	4.8 [0.189]

UNF thread

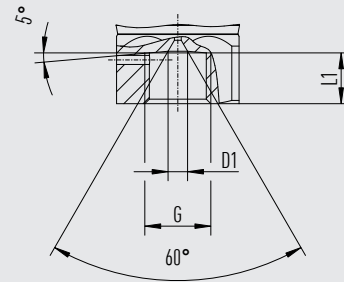

G	L1	D1
9/16-18 UNF-2B (F250-C)	11.2 [0.441]	4.3 [0.169]

Flush threaded connections

G ½ B flush

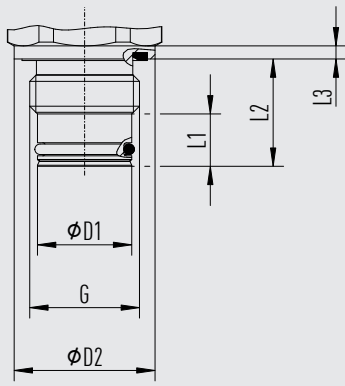

G	L1	L2	L3	D1	D2
G ½ B	10 [0.39]	20.5 [0.807]	3 [0.12]	18 [0.71]	26.9 [1.059]

G 1 B flush

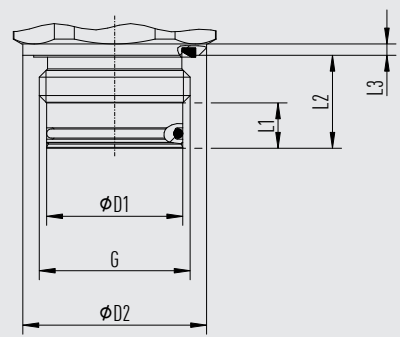

G	L1	L2	L3	D1	D2
G 1 B	10 [0.39]	20.5 [0.807]	2.5 [0.098]	30 [1.18]	40.5 [1.595]

G 1 B hygienic

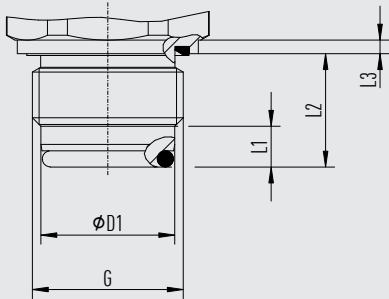

G	L1	L2	L3	D1
G 1 B	9 [0.35]	25 [0.98]	3 [0.12]	29.5 [1.161]

G 1 B hygienic 3A

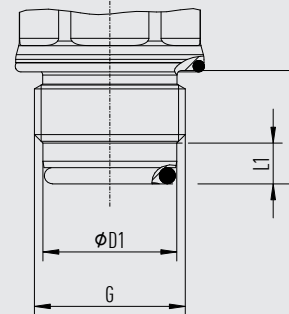

G	L1	D1
G 1 B	9 [0.35]	29.5 [1.161]

Tapped holes in mm

Tapped holes are only shown for WIKA-specific threads. For all other tapped holes, observe the applicable standards.

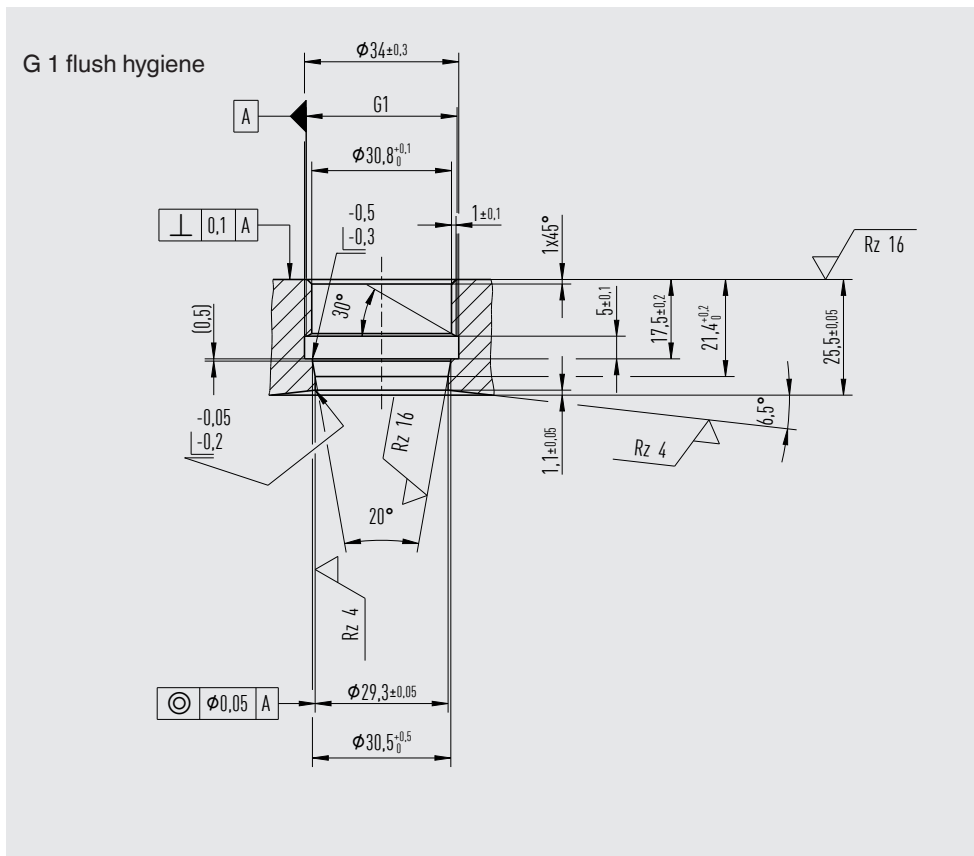
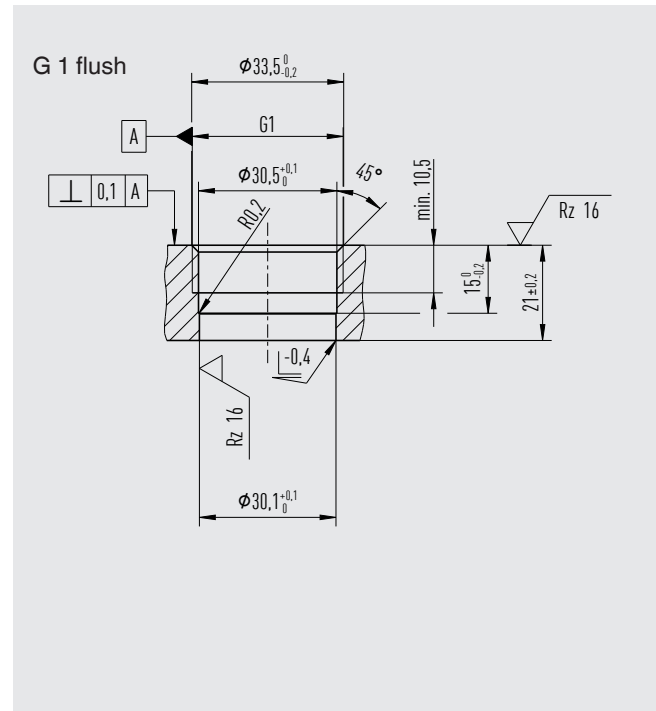
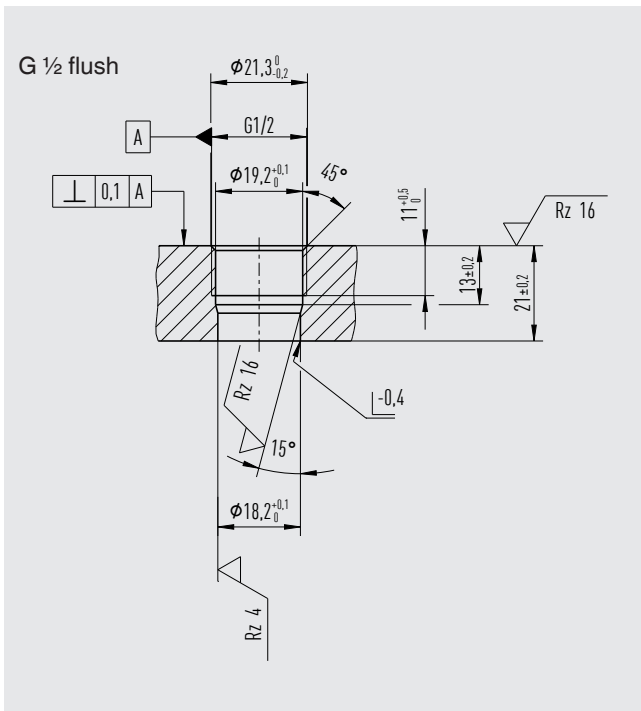

Tapped holes in inch

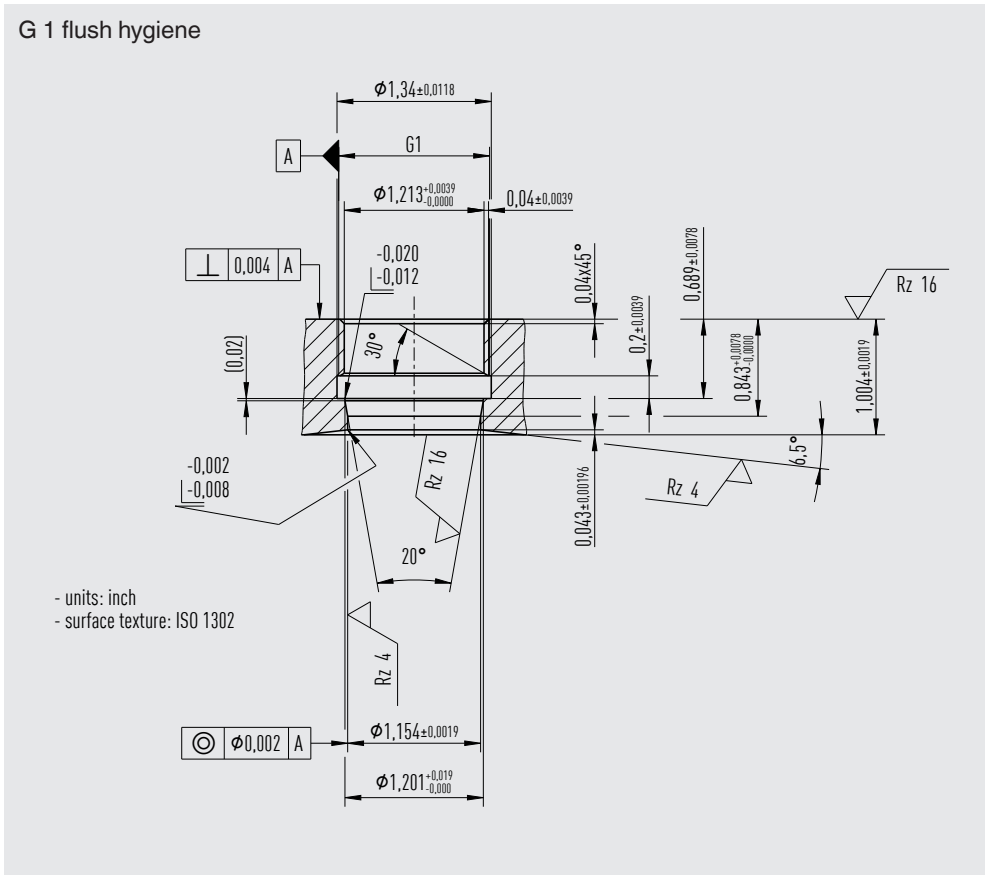
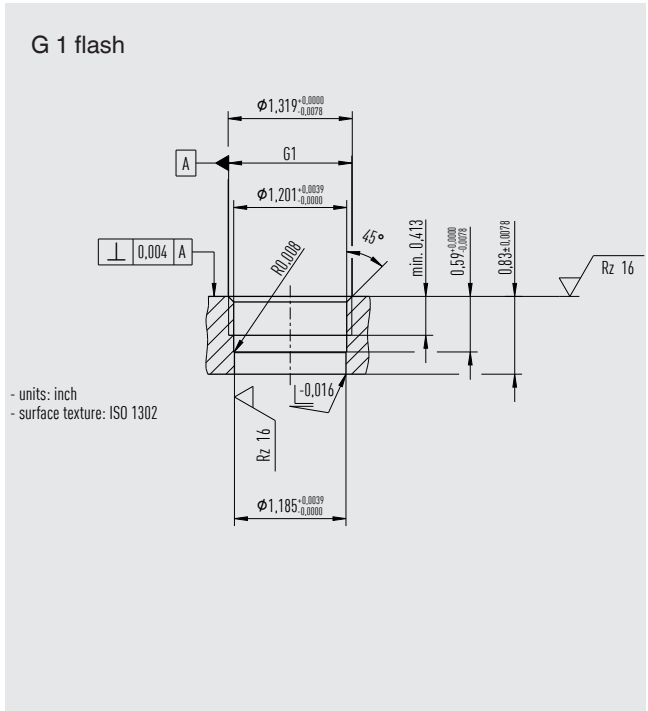
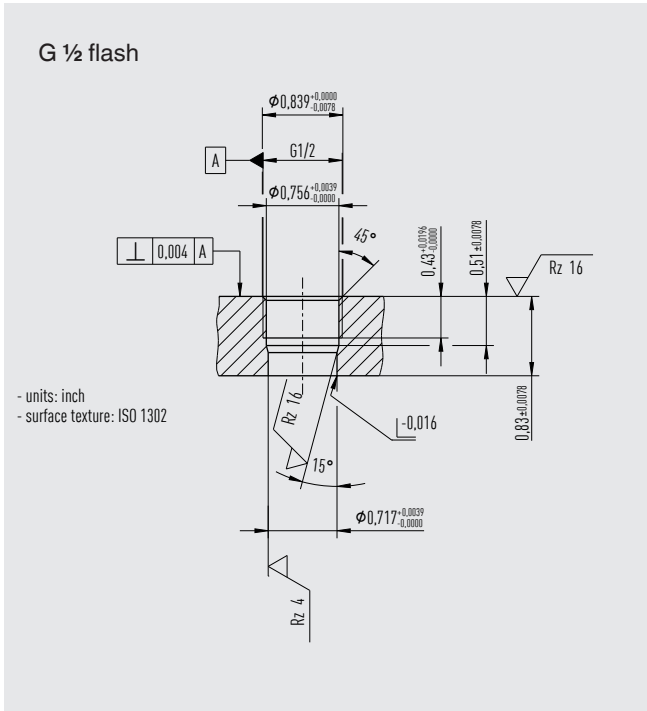

Max. measuring ranges and overpressure limits depending on the process connections

Thread size	Seal	Max. measuring range in bar [psi]	Overpressure limit in bar [psi]
EN 837			
G 3/8 B, male	WIKA seal ¹⁾	1,035 [15,000]	1,480 [21,500]
G 1/8 B, male	WIKA seal ¹⁾	400 [5,800]	572 [8,200]
G 1/4 B, male	WIKA seal ¹⁾	1,035 [15,000]	1,480 [21,500]
G 1/4, female	WIKA seal ¹⁾	1,035 [15,000]	1,480 [21,500]
G 1/2 B, male	WIKA seal ¹⁾	1,035 [15,000]	1,480 [21,500]
G 1/2 B, male ³⁾	Without (from $\geq 1,000$ bar ⁴⁾)	1,600 [23,200]	2,288 [33,185]
DIN EN ISO 1179-2			
G 1/8 A, male	Elastomer seal ²⁾	250 [3,600]	358 [3,700]
G 1/4 A, male	Elastomer seal ²⁾	600 [8,700]	858 [12,400]
G 1/4 A, male	Elastomer seal (item no. 14045531)	1,035 [15,000]	1,480 [21,500]
G 1/2 A, male	Elastomer seal ²⁾	600 [8,700]	858 [12,400]
DIN EN ISO 9974-2			
M10 x 1.0, male	Elastomer seal ²⁾	250 [3,600]	358 [3,700]
M14 x 1.5, male	Elastomer seal ²⁾	600 [8,700]	858 [12,400]
ANSI/ASME B1.20.1			
1/8 NPT, male	Self-sealing	400 [5,800]	572 [8,300]
1/4 NPT, male	Self-sealing	1,035 [15,000]	1,480 [21,500]
1/4 NPT, female	Self-sealing	1,035 [15,000]	1,480 [21,500]
1/2 NPT, male	Self-sealing	1,035 [15,000]	1,480 [21,500]
1/2 NPT, male ³⁾	Self-sealing	1,600 [23,200]	2,288 [33,185]
ISO 7			
R 3/8, male	WIKA seal ¹⁾	1,035 [15,000]	1,480 [21,500]
R 1/4, male	WIKA seal ¹⁾	1,035 [15,000]	1,480 [21,500]
R 1/2, male	WIKA seal ¹⁾	1,035 [15,000]	1,480 [21,500]
SAE J514			
3/4-16 UNF-2A SAE J514 O-ring BOSS	Elastomer seal ²⁾	600 [8,700]	858 [12,400]
7/16-20 UNF-2A SAE J514 O-ring BOSS	Elastomer seal ²⁾	600 [8,700]	858 [12,400]
7/16-20 UNF-2A SAE J514 74°	Self-sealing	800 [11,600]	1,144 [16,600]
9/16-18 UNF-2A SAE J514 O-ring BOSS	Elastomer seal ²⁾	600 [8,700]	858 [12,400]
JIS B2351-1			
G 3/8, male, form O with collar	Elastomer seal ²⁾	600 [8,700]	858 [12,400]
G 1/4 x 10, male, form O with collar	Elastomer seal ²⁾	600 [8,700]	858 [12,400]
DIN 16288			
M20 x 1.5, male	WIKA seal ¹⁾	1,035 [15,000]	1,480 [21,500]
M20 x 1.5, male ³⁾	Without (from ≥ 1000 bar ⁴⁾)	1,600 [23,200]	2,288 [33,185]
DIN 16288 (similar to EN 837)			
M12 x 1.5, male (similar to EN 837)	WIKA seal ¹⁾	1,035 [15,000]	1,480 [21,500]
M12 x 1.5, male (similar to EN 837) ³⁾	Without (from ≥ 1000 bar ⁴⁾)	1,600 [23,200]	2,288 [33,185]
JIS B7505-76			
G 1/4 B, male	WIKA seal ¹⁾	1,035 [15,000]	1,480 [21,500]
ISO 6149-2			

Thread size	Seal	Max. measuring range in bar [psi]	Overpressure limit in bar [psi]
M14 x 1.5	Elastomer seal ²⁾	600 [8,700]	858 [12,400]
ISO 8434-1			
G ¼, female (compatible with bite-type fittings)	Without ⁴⁾	1,035 [15,000]	1,480 [21,500]
KS B 0222			
PT ¾, male	self-sealing	1,035 [15,000]	1,480 [21,500]
PT ¼, male	self-sealing	1,035 [15,000]	1,480 [21,500]
PT ½, male	self-sealing	1,035 [15,000]	1,480 [21,500]
Without			
G ½, flush	NBR, up to 120 °C	600 [8,700]	1,200 [17,400]
G ½, flush	FKM, up to 100 °C	420 [6,100]	600 [8,700]
G ½, flush	EPDM, up to 150 °C	280 [4,100]	400 [5,800]
G ½, flush	FFKM, up to 150 °C	600 [8,700]	1,200 [17,400]
M16 x 1.5 female with sealing cone	Without ⁴⁾	7,000 [101,500]	8,000 [116,000]
M20 x 1.5 female with sealing cone	Without ⁴⁾	15,000 [217,600]	16,000 [232,100]
9/16-18 UNF, female F250-C	Without ⁴⁾	7,000 [101,500]	8,000 [116,000]
G 1 B hygienic 3A	Elastomer seal ²⁾	Not required ⁵⁾	Not required ⁵⁾
G 1 B hygienic	Elastomer seal ²⁾	Not required ⁵⁾	Not required ⁵⁾
G 1 B, flush	Elastomer seal ²⁾	Not required ⁵⁾	Not required ⁵⁾

1) Per DS AC 09.08 (materials only Cu and 1.4571)

2) Per section "Spare parts" of the respective DS

3) Process connection from CrNiMo steel 1.4542

4) The information on the maximum measuring range and overpressure limit refers to the process connection. Depending on the selected process connection and the seal, restrictions in overpressure limit can result.

5) It is not necessary to specify the maximum measuring range and overpressure limit, as the thread is only used for significantly lower measuring ranges.

Details must be tested separately in the respective application. The specified values for the overpressure limit serve only as a rough orientation. The values depend on the temperature, the seal used, the selected torque, the type and the material of the mating thread and the prevailing operating conditions.

→ Other customised process connections on request

© 04/2003 WIKA Alexander Wiegand SE & Co. KG, all rights reserved.
The specifications given in this document represent the state of the art at the time of publishing.
We reserve the right to make modifications to the specifications and materials.



WIKA Alexander Wiegand SE & Co. KG
Alexander-Wiegand-Straße 30
63911 Klingenberg/Germany
Tel. +49 9372 132-0
info@wika.de
www.wika.de

Conversion Table of commonly used pressure units

WIKA Data Sheet IN 00.08

SI Units - Engineering units (based on the metre)

		SI units						Engineering units						
		to	bar	mbar	μbar	Pa	kPa	MPa	mmHg	mmWS	mWS	kp/mm ²	kp/cm ²	atm
		from												
SI units	1 bar	1	10 ³	10 ⁶	10 ⁵	100	0.1	750.064	10.1972 · 10 ³	10.1972	10.1972 · 10 ⁻³	1.01972	0.986923	
	1 mbar	10 ⁻³	1	10 ³	100	0.1	0.1 · 10 ⁻³	750.064 · 10 ⁻³	10.1972	10.1972 · 10 ⁻³	10.1972 · 10 ⁻⁶	1.01972 · 10 ⁻³	0.986923 · 10 ⁻³	
	1 μbar	10 ⁻⁶	10 ⁻³	1	0.1	0.1 · 10 ⁻³	0.1 · 10 ⁻⁶	750.064 · 10 ⁻⁶	10.1972 · 10 ⁻³	10.1972 · 10 ⁻⁶	10.1972 · 10 ⁻⁹	1.01972 · 10 ⁻⁶	0.986923 · 10 ⁻⁶	
	1 Pa	10 ⁻⁵	0.01	10	1	10 ⁻³	10 ⁻⁶	7.50064 · 10 ⁻³	101.972 · 10 ⁻³	101.972 · 10 ⁻⁶	101.972 · 10 ⁻⁹	10.1972 · 10 ⁻⁶	9.86923 · 10 ⁻⁶	
	1 kPa	0.01	10	10 · 10 ³	10 ³	1	10 ⁻³	7.50064	101.972	101.972 · 10 ⁻³	101.972 · 10 ⁻⁶	10.1972 · 10 ⁻³	0.986923 · 10 ⁻³	
	1 MPa	10	10 · 10 ³	10 · 10 ⁶	10 ⁶	10 ³	1	7.50064 · 10 ³	101.972 · 10 ³	101.972	101.972 · 10 ⁻³	10.1972 · 10 ⁻³	9.86923	
Engineering units	1 mmHg	1.33322 · 10 ⁻³	1.33322	1.33322 · 10 ³	133.322	133.322 · 10 ⁻³	133.322 · 10 ⁻⁶	1	13.5951	13.5951 · 10 ⁻³	13.5951 · 10 ⁻⁶	1.35951 · 10 ⁻³	1.31579 · 10 ⁻³	
	1 mmWS	98.0665 · 10 ⁻⁶	98.0665 · 10 ⁻³	98.0665	9.80665	9.80665 · 10 ⁻³	9.80665 · 10 ⁻⁶	73.5561 · 10 ⁻³	1	10 ⁻³	10 ⁻⁶	0.1 · 10 ⁻³	96.7841 · 10 ⁻⁶	
	1 mWS	98.0665 · 10 ⁻³	98.0665	98.0665 · 10 ³	9.80665 · 10 ³	9.80665	9.80665 · 10 ⁻³	73.5561	10 ³	1	10 ⁻³	0.1	96.7841 · 10 ⁻³	
	1 kp/mm ²	98.0665	98.0665 · 10 ³	98.0665 · 10 ⁶	9.80665 · 10 ⁶	9.80665 · 10 ³	9.80665	73.5561 · 10 ³	10 ⁶	10 ³	1	100	96.7841	
	1 kp/cm ²	0.980665	0.980665 · 10 ³	0.980665 · 10 ⁶	98.0665 · 10 ³	98.0665	98.0665 · 10 ⁻³	735.561	10 · 10 ³	10	0.01	1	0.967841	
	1 atm	1.01325	1.01325 · 10 ³	1.01325 · 10 ⁶	101.325 · 10 ³	101.325	101.325 · 10 ⁻³	760	10.3323 · 10 ³	10.3323	10.3323 · 10 ⁻³	1.03323	1	

Corresponding pressure units: ■ 1 Pa = 1 N/m²
 ■ 1 hPa = 1 mbar
 ■ 1 mmHg = 1 Torr
 ■ 1 kp/cm² = 1 at (atü)

Notes

The table refers to DIN 1301 Part 1 (2002) and Part 3 (1979).
 In accordance with the Execution Ordinance to the law on units in metrology (Federal German Units Ordinance) from 13th December 1985 only the following units are admissible for pressures:

- pascal (Pa)
- bar (bar)
- millimetre of mercury (mmHg), but only for blood pressure and the pressure of other physical liquids in medicine

Valid for these units in accordance with Federal German Unit Ordinance are the definitions and conversion factors per DIN 1301.

Listed in Part 1 of this standard

- pascal as derived SI unit with special name and with special unit symbol
 - bar as generally applicable unit outside the SI
 - millimetre of mercury as unit outside the SI with limited area of application
- Part 3 of this standard defines amongst other things conversion factors for the following units
- conventional millimetre of mercury (mmHg)
 - conventional metre of water (mWS)
 - torr (Torr)
 - technical atmosphere (at)
 - standard atmosphere (atm)

SI units - Engineering units (based on the foot)

		SI units						Engineering units				
		to	bar	mbar	μbar	Pa	kPa	MPa	psi	ft H ₂ O	in. H ₂ O	in. Hg
		from										
SI units	1 bar	1	10 ³	10 ⁶	10 ⁵	100	0.1		14.50377	33.4553	401.463	29.52998
	1 mbar	10 ⁻³	1	10 ³	100	0.1	0.1		14.50377	33.4553	401.463	29.52998
	1 μbar	10 ⁻⁶	10 ⁻³	1	0.1	0.1	0.1		14.50377	33.4553	401.463	29.52998
	1 Pa	10 ⁻⁵	0.01	10	1	10 ⁻³	10 ⁻⁶		0.1450377	0.334553	4.01463	0.2952998
	1 kPa	0.01	10	10	10 ³	1	10 ⁻³		0.1450377	0.334553	4.01463	0.2952998
	1 MPa	10	10	10	10 ⁶	10 ³	1		0.1450377	0.334553	4.01463	0.2952998
Engineering units	1 psi	68.94757 · 10 ⁻³	68.94757	68.94757 · 10 ³	6.894757 · 10 ³	6.894757	6.894757 · 10 ⁻³		1	2.30666	27.6799	2.036020
	1 ft H ₂ O	29.8907 · 10 ⁻³	29.8907	29.8907 · 10 ³	2.98907 · 10 ³	2.98907	2.98907 · 10 ⁻³		433.5275	1	12	0.8826709
	1 in. H ₂ O	2.49089 · 10 ⁻³	2.49089	2.49089 · 10 ³	0.249089 · 10 ³	0.249089	0.249089 · 10 ⁻³		36.12729	83.3333	1	73.55591 · 10 ⁻³
	1 in. Hg	33.86389 · 10 ⁻³	33.86389	33.86389 · 10 ³	3.386389 · 10 ³	3.386389	3.386389 · 10 ⁻³		0.4911542	1.132925	13.59510	1

Corresponding pressure units:

- 1 Pa = 1 N/m²
- 1 psi = 1 lbf/in.²
- 1 mmHg = 1 Torr
- 1 kgf/cm² = 1 at

Notes

The table refers to ISO 31-1:1992 and ISO 31-3:1992
 For lengths ISO 31-1 defines conversion factors for units no longer to be used:

- inch (in)
- foot (ft)

For pressures ISO 31-3 defines conversion factors for units no longer to be used:

- pound-force per square inch (lbf/in.²)
- conventional millimetre of water (mmH₂O)
- conventional millimetre of mercury (mmHg)
- Torr (Torr)
- technical atmosphere (at)
- standard atmosphere (atm)

