

Snubber for pressure measuring instruments

Model 910.12, brass, steel or stainless steel

WIKA data sheet AC 09.03

Applications

- Snubbers protect pressure measuring instruments from pressure surges and pulsations in the medium
- Stainless steel version for aggressive media, even in aggressive environments
- Process industry: Machine building, general plant construction, chemical industry, petrochemical industry, power plants, mining, on-/offshore and environmental technology

Special features

- Max. temperature 120 °C
- Nominal pressures to 400 bar

**Fig. left: Brass version****Fig. right: Stainless steel version**

Configurator



Standard articles



Description

Snubbers are adjustable (modification of the flow cross-section) and can thus be adapted individually to the respective operating conditions. A readjustment during operation, if required, is possible at any time.

The pulsations and pressure surges in the medium, occurring e.g. in compressors, steam engines, hydraulic presses, tensile testing machines etc., are largely compensated by this device. Snubbers ensure a considerably prolonged service life of the pressure measuring instruments and improve the reading accuracy of pressure gauges.

Standard version

Connection to the pressure measuring instrument

G 1/2 female per EN 837-1/7.3

Process connection

G 1/2 B per EN 837-1/7.3

Options

- Material: Monel
- Other process connection: G 1/4, G 3/8 per EN 837-1/7.3, M20 x 1.5, 1/4 NPT, 1/2 NPT
- Oil and grease free for oxygen: max. 50 bar or +60 °C (for brass and 1.4571 materials only)
- Inspection certificate per DIN 50049 / EN 10204 3.1

Dimensions in mm

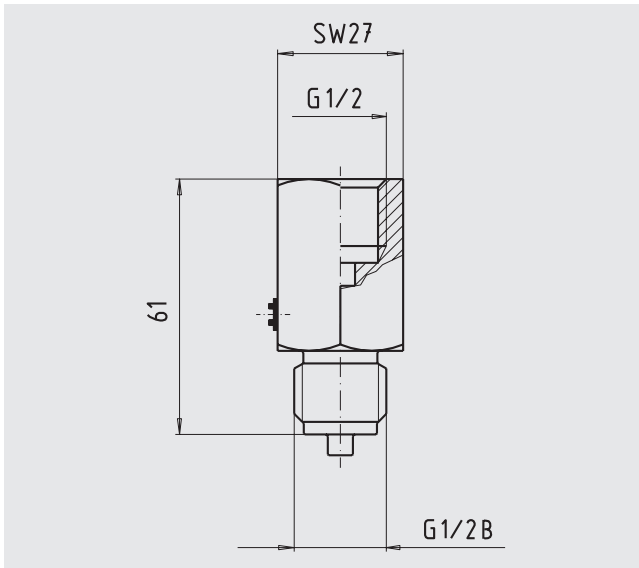

Operating principle

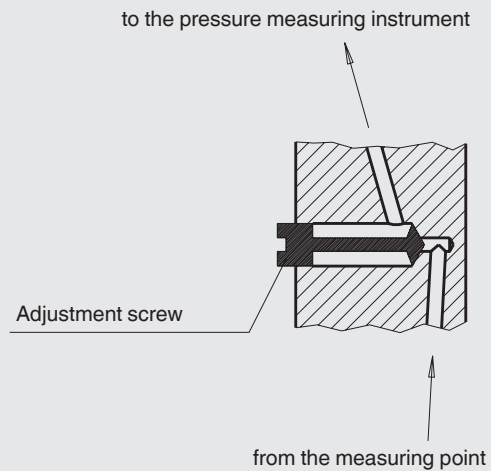

Material			PN	Temperature range	Order number
Body	Spindle	Sealing	bar		
Brass	1.4404 ²⁾	NBR	400	-10 ... +120 °C	9090185
Steel ¹⁾	1.4404 ²⁾	NBR	400	-10 ... +120 °C	9090193
1.4571 ²⁾	1.4404 ²⁾	FPM	400	-10 ... +120 °C	9091262

1) Rust-protected
2) Stainless steel

Ordering information

To order the described product the order number is sufficient.
Options require additional specification.

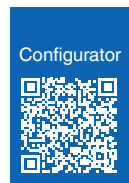

© 04/1995 WIKA Alexander Wiegand SE & Co. KG, all rights reserved.
The specifications given in this document represent the state of engineering at the time of publishing.
We reserve the right to make modifications to the specifications and materials.

