

Miniature resistance thermometer with wireless transmission

For general industrial applications

Model TRW

WIKA data sheet TE 63.04



Applications

- Preventive maintenance
- Remote monitoring of machinery and plants
- Energy and power plant technology
- Chemical industry
- Sanitary, heating and air-conditioning technology

Special features

- Long battery life through intelligent measurement control
- Easy integration thanks to several radio-standard options
- Numerous application possibilities – also as retrofit
- Robustly built, permanently reliable temperature measurement



Configurator



Miniature resistance thermometer with wireless transmission, model TRW

Description

The model TRW is a radio-based resistance thermometer for monitoring medium temperatures of all types. Resistance thermometers in this series can be installed directly into the process or combined with a large number of thermowell designs. It uses the licence-free LoRaWAN® and Bluetooth® radio standards and is used, for example, on mobile equipment and remote measuring points. Thanks to intelligent measurement and transmission control and a replaceable battery, the sensor can be operated for years without maintenance.

Long battery life through intelligent measurement control

The intelligent configuration allows measurement and transmission intervals that are dependent on the measured value. In addition, the sensor can measure continuously without transmitting every measured value. This means: high security with low data and energy consumption. All data is available digitally in a cost-efficient way and allows automated analyses.

Easy integration thanks to several radio-standard options

Thanks to numerous process connections and the two available standards – LoRaWAN® for the kilometre range and Bluetooth® for the metre range – the instrument can be flexibly configured.

Numerous application possibilities – also as retrofit

Via retrofit, machinery or moving parts can be configured smartly – without having to plan and document cable routing. Particularly when no continuous measurement is needed, cost advantages can be realised.

Robustly built, permanently reliable temperature measurement

The instrument is built to be robust and vibration-resistant. The battery is preassembled and can be replaced easily. It is not necessary to replace the entire resistance thermometer.

Specifications

Accuracy specifications	
Overall accuracy	<ul style="list-style-type: none"> ■ Measuring range ≤ 300 °C: +/- 1,4 °K ■ Measuring range > 300 °C: +/- 2,9 °K
Reference conditions	Per IEC 62828-1

Measuring range	
Temperature range ¹⁾	<ul style="list-style-type: none"> ■ -196 ... +300 °C [-321 ... +572 °F] ■ -50 ... +300 °C [-58 ... +572 °F] ■ -50 ... +500 °C [-58 ... +932 °F]
Version with FKM O-ring	-20 ... +125 °C [-4 ... +257 °F]

1) The temperature transmitter should therefore be protected from temperatures below -20 °C [-4 °F] and over +60 °C [+140 °F].

Process connection	
Type of process connection	<ul style="list-style-type: none"> ■ G ¼ B ■ G ⅜ B ■ G ½ B ■ ¼ NPT ■ ½ NPT ■ M12 x 1.5 ■ M20 x 1.5 ■ 7/16-20 UNF-2A ■ without ■ G ¼ B compression fitting (metal ferrule) ■ G ⅜ B compression fitting (metal ferrule) ■ G ½ B compression fitting (metal ferrule) ■ ¼ NPT compression fitting (metal ferrule) ■ ½ NPT compression fitting (metal ferrule) ■ G ¼ B compression fitting (PTFE ferrule) ■ G ⅜ B compression fitting (PTFE ferrule) ■ G ½ B compression fitting (PTFE ferrule) ■ ¼ NPT compression fitting (PTFE ferrule) ■ ½ NPT compression fitting (PTFE ferrule) ■ G ⅜ union nut, spring-loaded sensor (for additional thermowell) ■ M24 x 1.5 female thread, spring-loaded sensor (for additional thermowell / neck tube) ■ Tightening strap (for fitting on surface)

Sensor	
Sensor diameter	<ul style="list-style-type: none"> ■ 3 mm [0.12 in] ■ 6 mm [0.24 in]
Insertion length ¹⁾	<ul style="list-style-type: none"> ■ 50 mm [1.97 in] ■ 75 mm [2.95 in] ■ 100 mm [3.94 in] ■ 120 mm [4.72 in] ■ 150 mm [5.91 in] ■ 200 mm [7.87 in] ■ 250 mm [9.84 in] ■ 300 mm [11.81 in] ■ 350 mm [13.78 in] ■ 400 mm [15.75 in] <p>→ Other insertion lengths on request</p>

Thermowell/protection tube ²⁾	
Connection to thermometer	<ul style="list-style-type: none"> ■ G ⅜ union nut, spring-loaded sensor ■ M24 x 1,5 female thread, spring-loaded sensor

1) The first 60 mm [2.59 in] of the probe tip must not be bent. At the transition to the transmitter, bending is allowed at a distance of 30 mm [1.18 in] from the case. The sheathed resistance thermometer may be bent with a radius of 5 times the diameter.

2) Various thermowells/protection tubes can be combined with the TRW.

Thermowell/Protection tube examples for sanitary applications

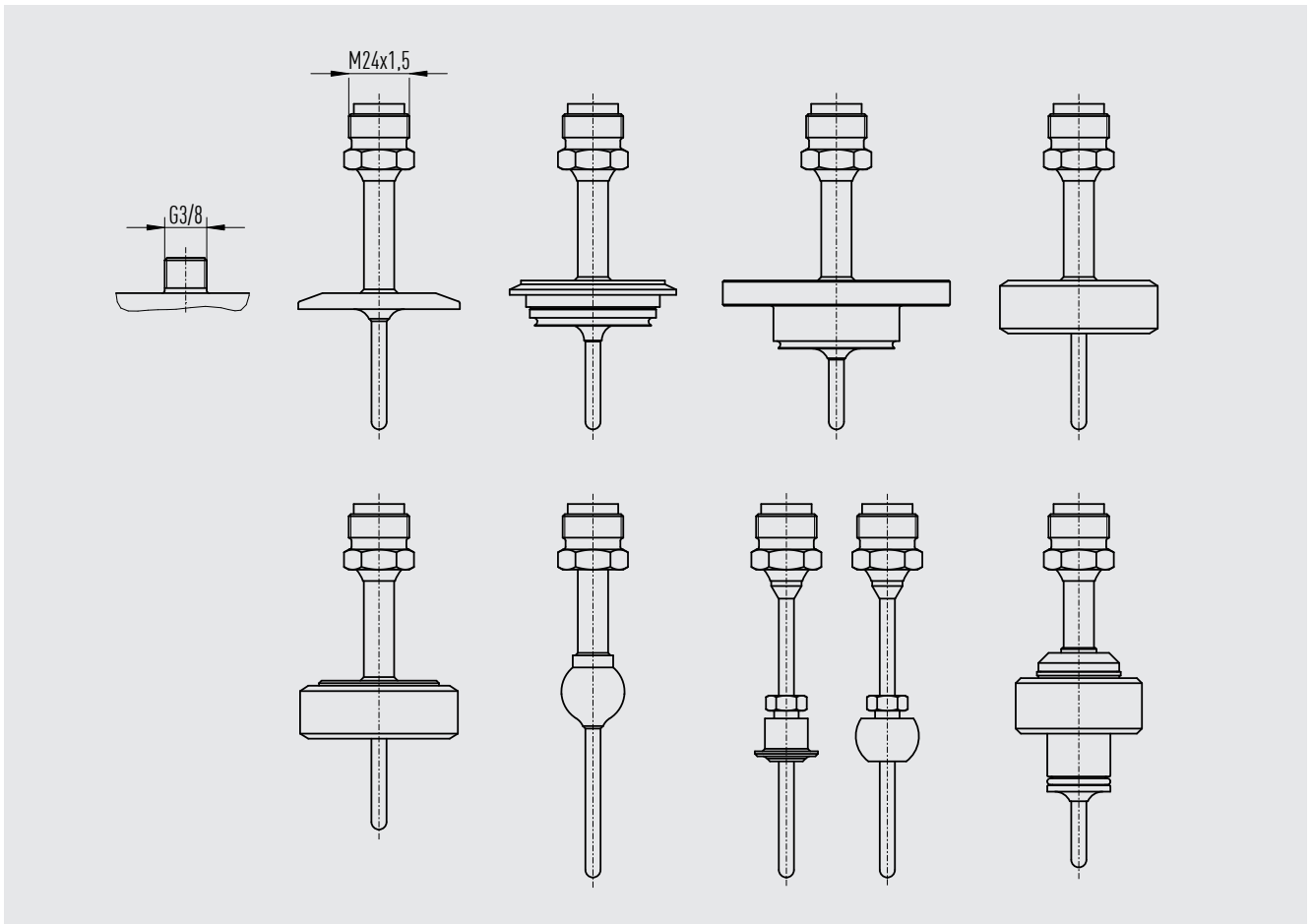

→ For details, see data sheet TW 95.22

Radio standard		
LoRaWAN®		
Specification	LoRaWAN® 868 MHz EU	
Protocol version	1.0.3	
Protocol functions	<ul style="list-style-type: none"> ■ Registration ■ Configuration ■ Sending measured values ■ Alarm management ■ Battery status 	
Frequency range	863 ... 870 MHz	
Range in free field	Typically 10 km [6 mi] → Depending on the ambient conditions, such as topography and building structures.	
Antenna	PCB antenna, internal	
Channel spacing	200 kHz	
Bandwidth	125 kHz	
Max. transmission power	14 dBm	
Transmission interval	Standard	30 minutes
	Minimum	1 minute (maximum transmission rate limited per ETSI EN 300 220) → Limitation of the transmission interval in accordance with ETSI EN 300 220 possible. The maximum transmission frequency and duty cycle comply with the standard ETSI EN300 220.
	Maximum	7 days
Security	Full end-to-end encryption per AES-128 → For details on security, see website: https://lora-alliance.org	
Bluetooth®		
Version	Bluetooth® 5.0 or newer → Compatible with all Bluetooth® Low Energy versions 4.2 or newer	
Functions	<ul style="list-style-type: none"> ■ Registration ■ Configuration ■ Sending measured values ■ Alarm management ■ Battery status ■ Data logger 	
Frequency range	2.4 GHz	
Range in free field	Typically 10 m [32.8 ft], free field → Depending on the ambient conditions, such as topography and building structures.	
Max. transmission power	4 dBm	
Antenna	Chip antenna, internal	
Transmission interval	1.25 seconds	
	→ Update of the measured value only occurs in the set measuring interval.	

→ For further information on the radio protocols, see www.wika.com.

Voltage supply and performance data		
Battery pack	Lithium thionyl chloride battery (model Tadiran SL860/S and hybrid layer capacitor (model Tadiran HLC1020L) as an assembly with connection cable assembled, see spare parts on page 9.	
Battery voltage	DC 3.6 V	
Battery life	> 10 years (measuring and transmission interval 1 hour, spreading factor 10) → At reference conditions	
Current supply	Max. 50 mA	
Measuring interval	Standard	1 minute
	Minimum	10 seconds → Smaller measuring intervals on request
	Maximum	7 days

LPWAN infrastructure

A measuring instrument that allows remote transmission via radio must be integrated into the IIoT infrastructure. The following schematic illustration shows a typical LPWAN infrastructure:

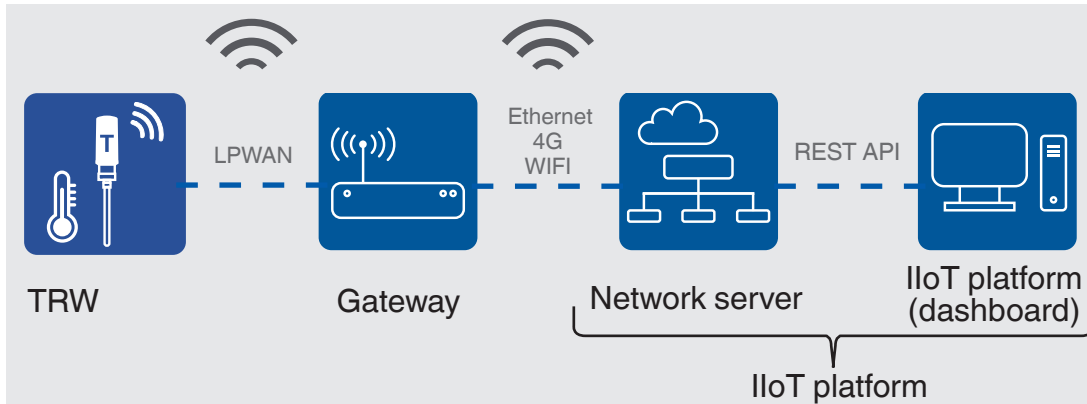

Data from an IIoT-capable measuring instrument is transmitted wirelessly via radio to the gateway. It is ensured that only authorised end devices may communicate with the network server (e.g. LoRaWAN®). For this, the measuring instrument must first be coupled with the network server. In LoRaWAN® the wireless transmission is typically 10 km [6 mi]. The range is dependent on the topography, placement of the gateway and environmental influences.

Measured values from several hundred LoRaWAN®-enabled IIoT devices can be collected by a gateway and transmitted to the network server via cable (e.g. Ethernet) or over-the-air (e.g. 4G or WLAN).

In a web-based IIoT platform, the measured data can be stored, alarms can be set and configurations can be made on the instrument. If the limit values are exceeded, alarm messages can be sent as notification via e-mail. The measured data can be analysed via the visualisation in the dashboard, thus enabling remote monitoring of the process pressure. WIKA provides the app “myWIKa wireless device” to support commissioning and local status inquiries of the measuring instrument.

“myWIKa wireless device” app

Via the “myWIKa wireless device” app, the measuring instrument can be configured. Furthermore, the instrument data and the current measured values can be read. The app functions are used via Bluetooth® and a Bluetooth®-capable end device.



Functions of the app:

- Indication of the instrument information
- Indication of the instrument status
- Readout of the current measured values
- Manual join request for the LoRaWAN® network
- Configuration such as measuring and transmission rate, alarm values, etc.

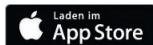

For iOS-based end devices, the app is available in the Apple Store via the link below.

[Download here:](#)



For Android-based end devices, the app is available in the Play Store via the link below.

[Download here:](#)



Material	
Materials (wetted)	
Sheath material	<ul style="list-style-type: none"> ■ Stainless steel 1.4571 ■ Stainless steel 316L
Process connection	<ul style="list-style-type: none"> ■ Stainless steel 1.4571 ■ Stainless steel 316L

Operating conditions	
Ambient temperature range	-20 ... +60 °C [-4 ... +140 °F] ¹⁾
Storage temperature range	-40 ... +70 °C [-40 ... +158 °F] Version with FKM O-ring -20 °C [-4 °F]
Altitude in accordance with EN 61010-1	Max. 2,000 m [6561.68 ft] above sea level
Relative humidity	20 ... 90 %, non-condensing
Maximum operating pressure ^{2) 3)}	
With sensor diameter 3 mm [0.12 in]	140 bar [2,030 psi]
With sensor diameter 6 mm [0.24 in]	270 bar [3,916 psi]
Permissible pollution degree per EN 61010-1	2
Vibration resistance per IEC 60068-2-6	5 g (10 ... 200 Hz) ⁴⁾
Shock resistance per IEC 60068-2-27	10 g, 11 ms
Free fall per IEC 60068-2-31	Individual packaging 1.2 m [3.94 ft]
Ingress protection per IEC/EN 60529	<ul style="list-style-type: none"> ■ IP65 ■ IP67
Weight	Approx. 0.05 ... 0.7 kg [0.11 ... 1.54 lbs] - depending on version

1) Version -40 ... +60°C [-40 ... +140 °F] on request:

2) Dependent on the instrument version. In combination with an additional thermowell, this determines the maximum operating pressure

3) Reduced operating pressure when using a compression fitting: Stainless steel: max. 100 bar [1,450 psi] / PTFE = max. 8 bar [116 psi]

4) Dependent on the instrument version. Specification applies to instrument versions without neck tube and for a maximum insertion length < 100 mm [3.94 in].
For insertion lengths > 100 mm [3.94 in] with limitation to 3 g max.

Alarms	
Alarms	Various alarms can be set. → See operating instructions for details

Approvals

Logo	Description	Country
CE	EU declaration of conformity	European Union
	RED - Radio Equipment Directive EN 61326 emission (group 1, class B) and immunity (industrial application) This wireless device may be used without restriction in the member states of the EU and in the countries UK, CH, NO, LI. Use in other countries is not permitted.	
	RoHS directive	

Certificates

Certificates	
Certificates	<ul style="list-style-type: none"> ■ 2.2 test report per EN 10204 (e.g. state-of-the-art manufacturing, material proof) ■ 3.1 inspection certificate per EN 10204 (e.g. material proof for wetted metal parts)

→ For approvals and certificates, see website

Dimensions in mm [in]

Legend:	$\varnothing d$ Sensor diameter
A Insertion length	X Height process connection
L1 Thread length	1/4 NPT = 15 mm [0.59 in]
N (MH) Neck length	1/2 NPT = 19 mm [0.75 in]

Process connection with parallel thread (or without process connection)

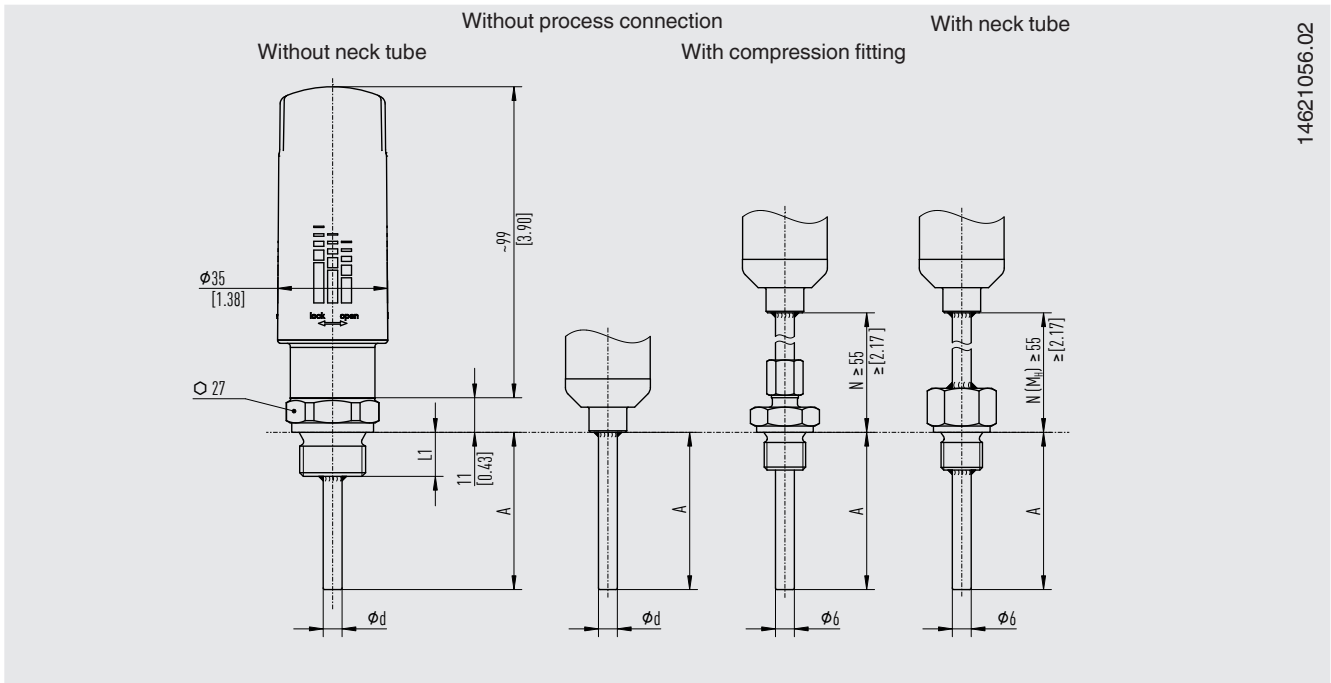

14621056.02

Process connection with parallel thread (7/16-20 UNF-2A) and O-ring

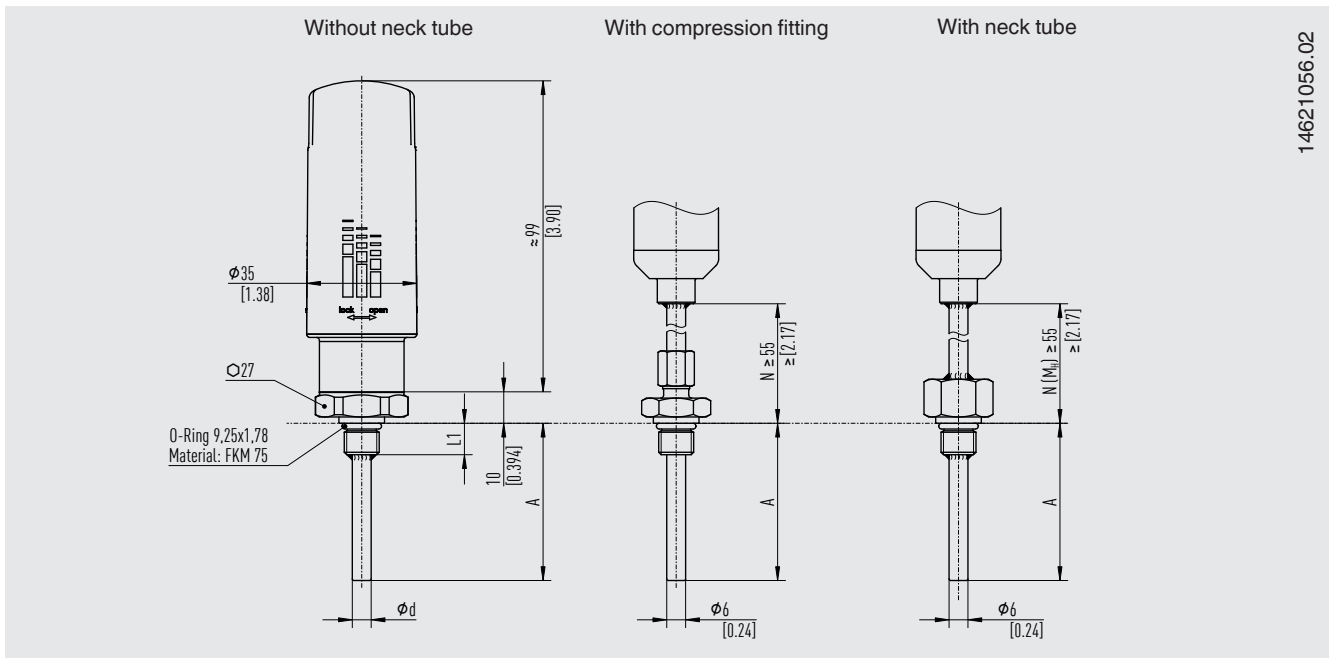

14621056.02

The FKM O-ring must be protected from temperatures lower than $-20\text{ }^{\circ}\text{C}$ [$-4\text{ }^{\circ}\text{F}$] and higher than $125\text{ }^{\circ}\text{C}$ [$257\text{ }^{\circ}\text{F}$].

Process connection with tapered thread

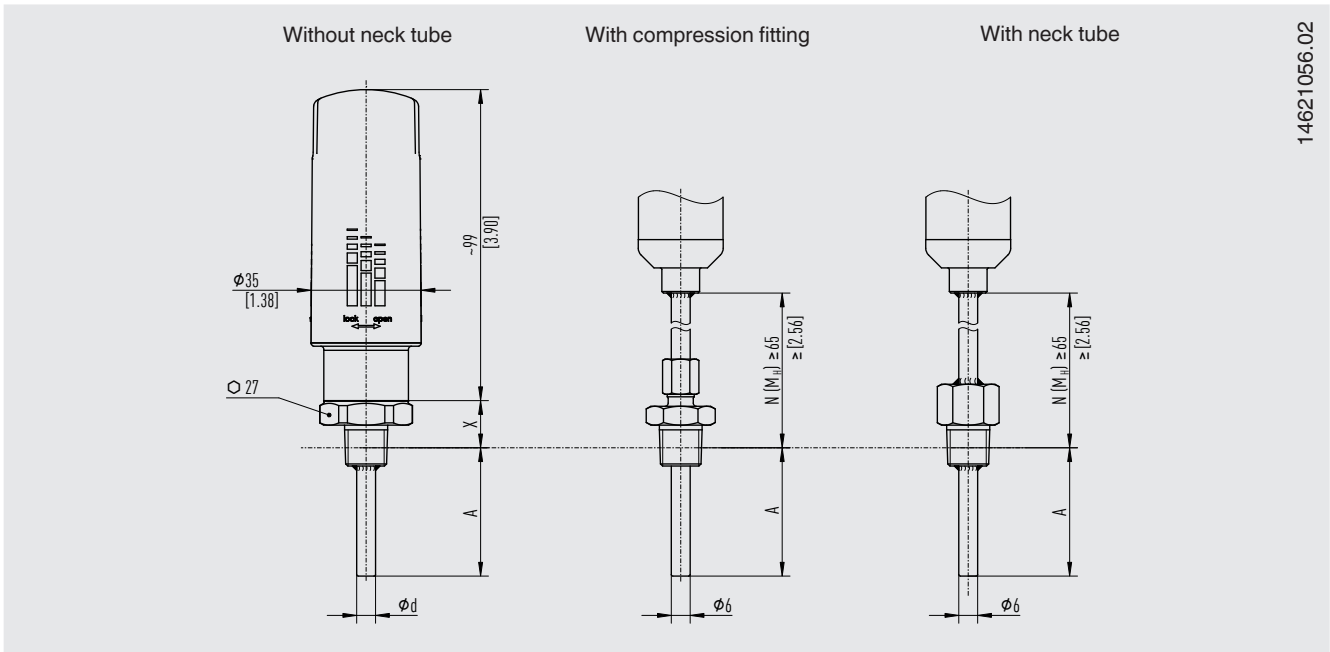

14621056.02

At a process temperature of $> 150\text{ }^{\circ}\text{C}$ [$302\text{ }^{\circ}\text{F}$], a neck length N (MH) of 70 mm [2.76 in] is necessary, otherwise N (MH) selectable (55 mm [2.17 in], 65 mm [2.56 in] or 70 mm [2.76 in]).

Spring-loaded process connection

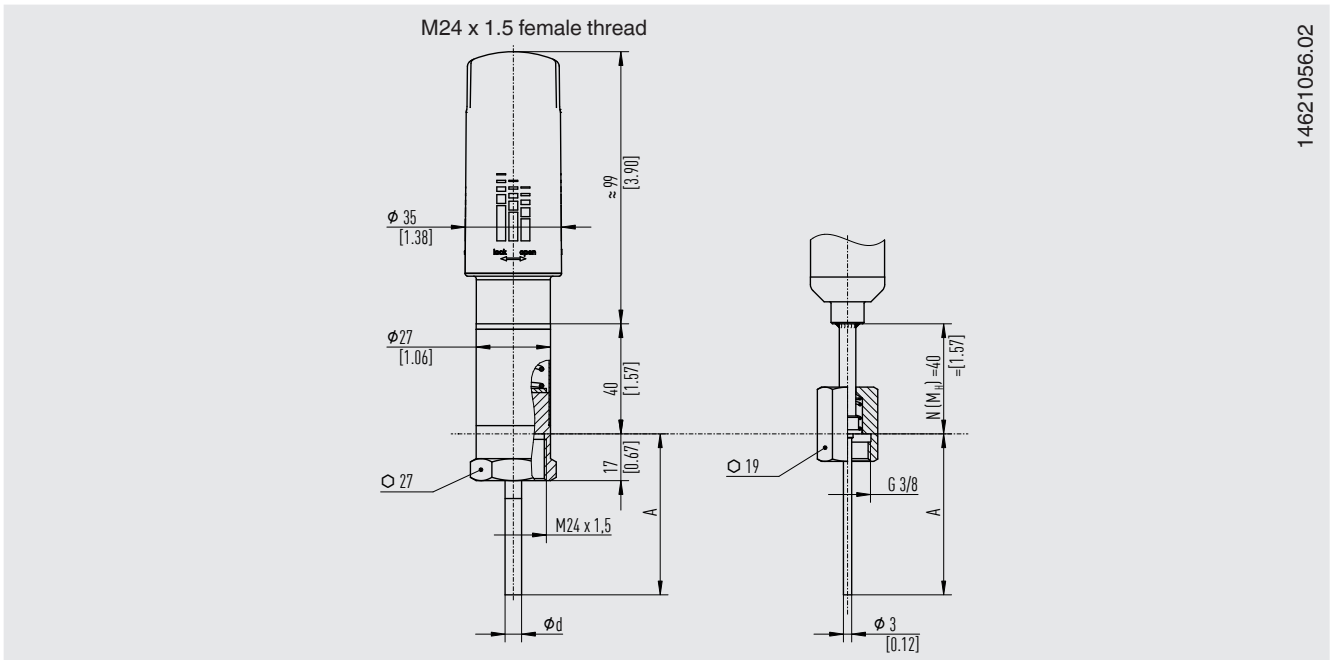

14621056.02

The neck length depends on the intended use. Usually an isolation is bridged by the neck tube. Also, in many cases, the neck tube serves as a cooling element in order to protect a possible built-in transmitter from high medium temperatures.

Process connection for surface measurement

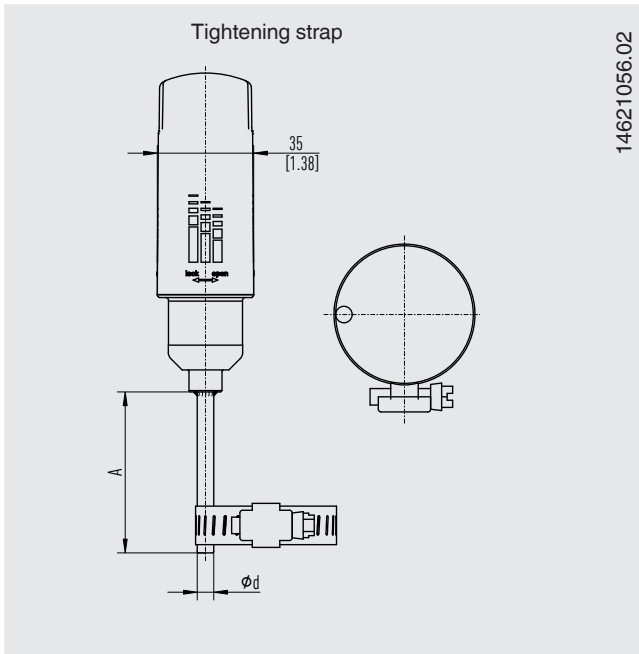

Tightening strap for pipe diameter

11 ... 15 mm [0.43 ... 0.59 in]
13 ... 25 mm [0.51 ... 0.98 in]
23 ... 62 mm [0.91 ... 2.44 in]
60 ... 93 mm [2.36 ... 3.66 in]
91 ... 125 mm [3.58 ... 4.92 in]
123 ... 158 mm [4.84 ... 6.22 in]
→ Other sizes on request: 159 ... 2,500 mm [6.26 ... 98.43 in]

→ Other process connections, see data sheet TW 95.22

Accessories

Model	Order number
LoRaWAN® gateway, preconfigured for WIKA network server	
Gateway for indoor use	On request
Gateway for outdoor use	On request

Spare parts

Model	Description	Order number
Battery	Lithium thionyl chloride battery and hybrid layer capacitor (model Tadiran HL-C1020L) as an assembly with connection cable assembled.	14392747
	Model Tadiran SL860/S	2,4 Ah

Ordering information

Model / Approvals / Process temperature / Radio standard / Region of use / Connection to platform / Process connection / Material of process connection / Sensor diameter / Sheath material / Insertion length A / Neck length N (MH) / Certificates



To order the described product the order number is sufficient.

LoRaWAN® ist eine Marke, die unter Lizenz der LoRa-Alliance® verwendet wird.

Die Bluetooth®-Wortmarke und -Logos sind eingetragene Marken im Besitz von Bluetooth SIG, Inc. und jede Verwendung dieser Marken durch WIKA erfolgt unter Lizenz. Andere Marken und Markennamen sind Eigentum der jeweiligen Inhaber.

© 09/2023 WIKA Alexander Wiegand SE & Co. KG, all rights reserved.

The specifications given in this document represent the state of engineering at the time of publishing.

We reserve the right to make modifications to the specifications and materials.

In case of a different interpretation of the translated and the English data sheet, the English wording shall prevail.



Operating instructions
Betriebsanleitung

Miniature resistance thermometer with wireless transmission,
model TRW

EN

Miniatur-Widerstandsthermometer mit Funkübertragung,
Typ TRW

DE



Miniature resistance thermometer with wireless transmission,
model TRW



EN	Operating instructions model TRW	Page	3 - 44
-----------	---	-------------	---------------

DE	Betriebsanleitung Typ TRW	Seite	45 - 87
-----------	----------------------------------	--------------	----------------

© 11/2023 WIKA Alexander Wiegand SE & Co. KG
All rights reserved. / Alle Rechte vorbehalten.
WIKA® is a registered trademark in various countries.
WIKA® ist eine geschützte Marke in verschiedenen Ländern.

LoRaWAN® ist eine Marke, die unter Lizenz der LoRa-Alliance® verwendet wird.
Die Bluetooth®-Wortmarke und -Logos sind eingetragene Marken im Besitz von Bluetooth SIG, Inc. und jede Verwendung dieser Marken durch WIKA erfolgt unter Lizenz. Andere Marken und Markennamen sind Eigentum der jeweiligen Inhaber.

Prior to starting any work, read the operating instructions!
Keep for later use!

Vor Beginn aller Arbeiten Betriebsanleitung lesen!
Zum späteren Gebrauch aufbewahren!

14642235.02.02/2024 EN/DE

Content

1. General information	5
1.1 Abbreviations, definitions6
1.2 Explanation of symbols6
2. Safety	7
2.1 Intended use7
2.2 Improper use7
2.3 Personnel qualification8
2.4 Labelling, safety markings8
2.5 Contents of the QR code on the product label (example)9
2.6 Approved batteries	10
2.7 Safety description for power supply	10
2.8 Data transmission security	11
3. Transport, packaging and storage	12
3.1 Transport	12
3.2 Packaging and storage	13
4. Design and function	14
4.1 Overview	14
4.2 Scope of delivery	14
4.3 Description	15
4.4 Functional principle	15
5. Commissioning and operation	16
5.1 First configuration	18
5.2 Establishing the power supply	19
5.3 Connecting the radio unit to a measuring instrument	19
5.4 “myWIKA wireless device” app	21
5.5 Battery status	21
5.6 Connecting the radio unit within an LPWAN	21
5.7 Alarm description	22
6. Faults	25
7. Maintenance, cleaning and calibration	27
7.1 Maintenance	27
7.2 Battery handling	27
7.3 Cleaning	29

Content

8. Dismounting, return and disposal	29
8.1 Dismounting	29
8.2 Return.	30
8.3 Disposal	31
9. Specifications	32
10. Accessories and spare parts	43
Annex: EU declaration of conformity	88

EN

1. General information

- The instrument described in the operating instructions has been designed and manufactured using state-of-the-art technology. All components are subject to stringent quality and environmental criteria during production. Our management systems are certified in accordance with ISO 9001 and ISO 14001.
- These operating instructions contain important information on handling the instrument. Working safely requires that all safety instructions and work instructions are observed.
- Observe the relevant local accident prevention regulations and general safety regulations for the instrument's range of use.
- The operating instructions are part of the product and must be kept in the immediate vicinity of the instrument and readily accessible to skilled personnel at any time. Pass the operating instructions on to the next operator or owner of the instrument.
- Skilled personnel must have carefully read and understood the operating instructions prior to beginning any work.
- In case of a different interpretation of the translated and the English operating instructions, the English wording shall prevail.
- The general terms and conditions contained in the sales documentation shall apply.
- Subject to technical modifications.
- Further information:
 - Internet address: www.wika.de / www.wika.com
 - Relevant data sheet: TE 63.04
 - Additional documentation: Special documentation for LoRaWAN® communication protocol, model TRW, 14617652
 - Contact: Tel.: +49 9372 132-0

1. General information

EN

1.1 Abbreviations, definitions

■	Bullet
▶	Instruction
1. ... x.	Follow the instruction step by step
⇒	Result of an instruction
→	See ... cross-references
RTD	Resistance thermometer
PBT	Polybutylene terephthalate

1.2 Explanation of symbols



DANGER!

... indicates a directly dangerous situation resulting in serious injury or death, if not avoided.



WARNING!

... indicates a potentially dangerous situation that can result in serious injury or death, if not avoided.



CAUTION!

... indicates a potentially dangerous situation that can result in light injuries or damage to property or the environment, if not avoided.



DANGER!

... identifies hazards caused by electrical power. Should the safety instructions not be observed, there is a risk of serious or fatal injury.



DANGER!

... indicates a potentially dangerous situation in the hazardous area that can result in serious injury or death, if not avoided.



WARNING!

... indicates a potentially dangerous situation that can result in burns, caused by hot surfaces or liquids, if not avoided.



Information

... points out useful tips, recommendations and information for efficient and trouble-free operation.

2. Safety

2.1 Intended use

The resistance thermometer TRW transmits its temperature value to a higher-level system. The instrument can be used wherever an RTD value is digitalised and made available via Bluetooth® Low Energy or LoRaWAN®. Remote monitoring of the RTD value can be made through a web-based platform.

The instrument has been designed and built solely for the intended use described here, and may only be used accordingly.

The technical specifications contained in these operating instructions must be observed, see chapter 9 "Specifications". It is assumed that the instrument is handled properly and within its technical specifications. Otherwise, the instrument must be taken out of service immediately and inspected by an authorised WIKA service engineer. Handle electronic instruments with the required care (protect from humidity, impacts, strong magnetic fields, static electricity and extreme temperatures, do not insert any objects into the instrument or its openings).

The manufacturer shall not be liable for claims of any type based on operation contrary to the intended use.

2.2 Improper use



WARNING!

Danger due to emerging fire or explosion

The use of non-approved batteries can lead to personal injury, damage to the instrument and the environment due to fire.

- ▶ Only use approved batteries, see chapter 9 "Specifications".



The remote monitoring function must not be used for control purposes, as it cannot be guaranteed that data packets won't be lost during wireless transmission.

The LoRaWAN® signal may only be used for mobile applications to a limited extent. This applies particularly to high spreading factors.

- This instrument is not permitted to be used in hazardous areas.
- For applications with direct contact with foodstuffs this instrument is not suitable.
- Any use beyond or different to the intended use is considered as improper use.
- Refrain from unauthorised modifications to the instrument.
- Do not use this instrument in safety or emergency shutdown devices.

2. Safety

2.3 Personnel qualification



The activities described in these operating instructions may only be carried out by skilled personnel who have the qualifications described below.

EN

Skilled personnel

Skilled personnel, authorised by the operator, are understood to be personnel who, based on their technical training, knowledge of measurement and control technology and on their experience and knowledge of country-specific regulations, current standards and directives, are capable of carrying out the work described and independently recognising potential hazards.

2.4 Labelling, safety markings

The labelling, safety markings must be maintained in a legible condition.

Product label (example)

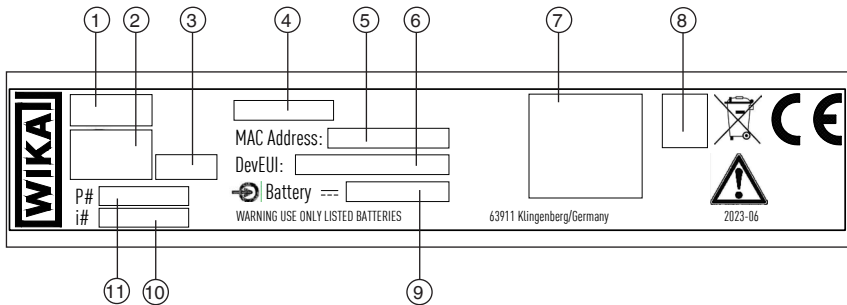

- ① Typ
- ② Funkstandards (für LoRaWAN® mit Angabe des „Regional Parameter WAN“)
- ③ Radio frequency
- ④ Ambient temperature
- ⑤ MAC-Adresse
- ⑥ DevEUI (nicht bei Bluetooth®)
- ⑦ QR-Code nach LoRa Alliance®-Spezifikation
- ⑧ Bluetooth®
- ⑨ Versorgungsspannung
- ⑩ Serial number
- ⑪ Article number

2. Safety

Symbols



Before mounting and commissioning the instrument, ensure you read the operating instructions!



Do not dispose of with household waste. Ensure a proper disposal in accordance with national regulations.



DC voltage

2.5 Contents of the QR code on the product label (example)



LW:D0:70B3D597B0000002:70B3D597B0004D71:02A30002:S1A01FZFCOJ6:PD-1883F69EBE3:CC9B3

Contents	Identifier	Example	Comment
SchemaID	-	D0	-
JoinEUI (64-bit)	-	70B3D597B0000002	JoinEUI = AppEUI
DevEUI (64-bit)	-	70B3D597B0004D71	-
ProfileID	-	02A30002	02A3 = VendorID WIKA; 0002 last 4 digits of the JoinEUI
SerNum	S	1A01FZFCOJ6	Alphanumeric WIKA serial number (11-digit)
Proprietary	P	D1883F69EBE3	Bluetooth® MAC address: D1:88:3F:69:EB:E3
Checksum	C	C9B3	-

2. Safety

2.6 Approved batteries

EN



CAUTION!

Physical injuries and damage to property and the environment

Lithium thionyl chloride batteries are not rechargeable. Improper handling can lead to leakage or escape of vapourised electrolyte vapours and cause a fire or explosion.

- ▶ Do not open the battery.
- ▶ Do not damage the battery cells.
- ▶ The positive and negative connections must not be short-circuited with conductors.
- ▶ Do not reverse the polarity.
- ▶ Do not expose the battery to excessive mechanical loads.
- ▶ Do not expose the battery to water or condensation.
- ▶ Do not heat, solder or expose the battery to fire.
- ▶ Do not use any rechargeable batteries.
- ▶ Do not use damaged batteries.

To ensure proper operation and the best possible performance, use only the battery listed, see chapter 10 “Accessories and spare parts”.

Battery

Battery pack

Lithium thionyl chloride battery and hybrid layer capacitor (model Tadiran HLC1020L) as an assembly with connection cable assembled.

Model Tadiran SL860/S

With battery version, use only the suitable case, see chapter 5.3 “Establishing the power supply” and 9 “Specifications”.

2.7 Safety description for power supply

Temperature range	-20 ... +60 °C [-4 ... +140 °F]
Voltage supply battery	3.6 V
Current supply	Max. 250 mA
Max. altitude	2,000 m [6561.68 ft]

14642235.02.02/2024 EN/DE

2.8 Data transmission security

LoRaWAN®

LoRaWAN® transmission uses the cryptographic principle of AES encryption in combination with several operating modes: for a secure data transmission, CMAC2 for integrity protection and CTR3 for encryption. Each LoRaWAN® device is personalised with a unique 128-bit AES key (AppKey) and a globally unique identifier (EUI-64-based DevEUI), both used during the device authentication process.

→ Further details can be found in the official LoRaWAN® Security White Paper from the LoRa Alliance®, see <https://lora-alliance.org>

Bluetooth® Low Energy

Bluetooth® Low Energy communicates in the licence-free 2.4 GHz ISM band and is a globally harmonised energy-efficient radio standard. Bluetooth® Low Energy uses 40 channels between 2.402 GHz and 2.480 GHz. Encryption is performed using the AES 128 encryption algorithm in combination with distributed key replacement.

The radio unit transmits the measured value as an optional broadcast message on the advertising channels 37, 38 and 39, in addition to the instrument name and the battery charge status. Further information and detailed configuration and command options are available via a point-to-point connection.



Pairing is established using a passkey entry method and requires the entry of a security code. Instrument settings can only be accessed after pairing has been completed. The pairing key is set individually for each instrument and is made available to the customer with the quick start guide. For individual applications, the pairing key can be configured by the user via the app.

If the security code is entered incorrectly 5 times, the instrument is blocked for connection with this code. After removing the battery, 5 attempts are once again available. If this is not possible for technical reasons, e.g. because the sensor cannot be reached to open the case, contact technical support.

3. Transport, packaging and storage

3. Transport, packaging and storage

3.1 Transport

EN



WARNING!

Damage from batteries and rechargeable batteries through improper transport

If loose or removed batteries are transported incorrectly, they can explode, burn or leak.

- ▶ Tape exposed contacts and pack the rechargeable batteries so that they do not move in the packaging (prevent short-circuit).
- ▶ Be careful when transporting and pay attention to the symbols on the packaging.



CAUTION!

Damage through improper transport

With improper transport, damage to property can occur.

- ▶ When unloading packed goods upon delivery as well as during internal transport, proceed carefully and observe the symbols on the packaging.
- ▶ With internal transport, observe the instructions in chapter 3.2 "Packaging and storage".

Check the instrument for any damage that may have been caused. In the event of any damage, do not commission the instrument and contact the manufacturer immediately.

If the instrument is transported from a cold into a warm environment, the formation of condensation may result in instrument malfunction. Prior to recommissioning, wait for the instrument temperature and the room temperature to equalise.

Strictly observe the following when shipping the instrument:

All instruments delivered to WIKA must be free from any kind of hazardous substances (acids, bases, solutions, etc.) and must therefore be cleaned before being returned.

Remove the batteries before returning.

The lithium-ion rechargeable batteries or lithium-metal batteries included are subject to the requirements of the dangerous goods law. Special requirements for packaging and marking must be observed when shipping. A dangerous goods expert must be consulted when preparing the package. Do not send any damaged or defective rechargeable batteries. Mask open contacts and pack the rechargeable battery so that it does not move in the packaging and also prevents short-circuits. Observe the different dangerous goods requirements relative to the respective modes of transport and any other national regulations.

14642235.02.02/2024 EN/DE

3. Transport, packaging and storage

EN

3.2 Packaging and storage

Do not remove packaging until just before mounting.

Keep the packaging as it will provide optimum protection during transport (e.g. change in place of use, sending for repair).

Permissible conditions at the place of storage:

- Storage temperature: -40 ... +70 °C [-32 ... +158 °F]
- Humidity: 35 ... 85 % relative humidity (non-condensing)

Avoid exposure to the following factors:

- Direct sunlight or proximity to hot objects
- Mechanical vibration, mechanical shock (putting it down hard)
- Soot, vapour, dust and corrosive gases
- Hazardous environments, flammable atmospheres

Store the instrument in its original packaging in a location that fulfils the previously listed conditions. Instruments that have already been commissioned must be cleaned before storage, see 7.3 „Reinigung“.

If the original packaging is not available, pack and store the instrument as described below:

1. Disconnect the battery.
2. Wrap the instrument in an anti-static plastic film.
3. Place the instrument, along with the shock-absorbent material, in the packaging.
4. If stored for a prolonged period of time (more than 30 days), place a bag containing a desiccant inside the packaging.

4. Design and function

4. Design and function

4.1 Overview

EN

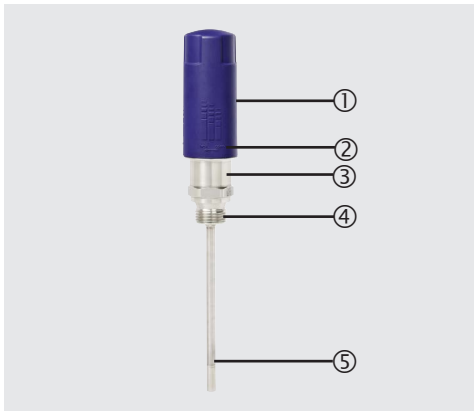

- ① Upper case part (removable)
- ② Battery compartment, Connector of the power supply
- ③ Case with product label
- ④ Process connection
- ⑤ Thermowell/protection tube

4.2 Scope of delivery

- Instrument model TRW
- Operating instructions
- Quick start guide with login credentials for commissioning (red envelope)
- Battery in the instrument

Cross-check scope of delivery with delivery note.

4. Design and function

EN

4.3 Description

The radio unit was developed in order to transmit sensor signals wirelessly. The instrument is connected to a sensor and takes readings from it. These values are made available in the respective radio protocol.

The wireless transmission is achieved via LoRaWAN[®] based on LPWAN technology (low-power wide-area network) to enable large transmission ranges and long battery life, or via Bluetooth[®] Low Energy. The instrument is powered by a battery.

The radio unit meets all safety requirements of relevant standards and regulations of the Radio Equipment Directive for data communication. The radio unit is a product that meets high requirements and transmits data with excellent reliability.

The transmission of the sensor signal to the IIoT platform is carried out at a preset sending interval. The sending intervals, and also the alarm limits, can be configured over the IIoT platform. In addition, the instrument status (current measured value, battery life, etc.) can also be queried and set on-site via a mobile device using a local interface via Bluetooth[®] Low Energy.

4.4 Functional principle

The radio unit uses the Bluetooth[®] Low Energy 4.2 radio standard which is designed for energy-saving operation. In connected mode, the radio unit can be configured on-site using a mobile device with the “myWIKA wireless device” app.

The last measured value recorded is transmitted via Bluetooth[®] Low Energy in “Advertising Mode” with an interval of 1.25 s. The measured value data can optionally be removed from the advertising.

→ For details on the Bluetooth[®] connection, see chapter 2.8 “Data transmission security” and the additional documentation “Special documentation for BLE communication specifications, model TRW”

Typical applications

- Signal recording
- Setting the alarm parameters
- Fault diagnosis
- Configuration ID (for the identification of changes in the sending rate)
- Configuration change (e.g. sending rate, alarm parameter etc.)



The analogue signal or RTD signal to be measured can only be set via Bluetooth[®].

5. Commissioning and operation

5. Commissioning and operation

Personnel: Skilled personnel

EN



WARNING!

Physical injury

When commissioning, there is a danger from aggressive media and high pressures

- ▶ Observe the information in the material safety data sheet for the corresponding medium.
- ▶ Before connecting to a vessel, pipeline or system, depressurise them.



WARNING!

Physical injuries and damage to property and the environment caused by hazardous media

Upon contact with hazardous media (e.g. oxygen, acetylene, flammable or toxic substances), harmful media (e.g. corrosive, toxic, carcinogenic, radioactive), and also with refrigeration plants and compressors, there is a danger of physical injuries and damage to property and the environment. Should a failure occur, hazardous media with extreme temperatures (over 55 °C [131 °F]) may be present at the instrument.

- ▶ For these media, in addition to all standard regulations, The appropriate existing codes or regulations must also be followed.
- ▶ Wear the requisite protective equipment.



WARNING!

Physical injuries and damage to property and the environment caused by hazardous media

Upon contact with hazardous media (e.g. oxygen, acetylene, flammable or toxic substances), harmful media (e.g. corrosive, toxic, carcinogenic, radioactive), and also with refrigeration plants and compressors, there is a danger of physical injuries and damage to property and the environment. Should a failure occur, hazardous media under high pressure or vacuum may be present at the instrument.

- ▶ For these media, in addition to all standard regulations, The appropriate existing codes or regulations must also be followed.
- ▶ Wear the requisite protective equipment.

5. Commissioning and operation

EN



WARNING!

Physical injuries and damage to property and the environment caused by media escaping under high pressure

With the pressurisation of the instrument, as a result of poor sealing of the process connection, media under high pressure can escape. Due to the high energy of the media that can escape in the event of a failure, the possibility of physical injuries and damage to property exists

- ▶ The sealing of the process connection must be carried out expertly and checked for leak tightness.



CAUTION!

Damage to property due to electrostatic discharge (ESD)

When working on open circuits (PCBs) there is a danger of damaging sensitive electronic components through electrostatic discharge.

- ▶ The correct use of grounded working surfaces and personal armbands is required.
- ▶ When the battery compartment is open, e.g. when changing the battery, sufficient ESD protection must be ensured.
- ▶ Do not touch PCBs and electrical components.
- ▶ Before removing the plastic cover, touch any part of the grounded metal case or an adjacent grounded metal object (e.g. radiator, pipelines) (static charges are dissipated from the body).
- ▶ Avoid contact between the electronics and clothing.

Only use original parts, see chapter 10 “Accessories and spare parts”.

Check the instrument for any damage that may have been caused.

In the event of any damage, do not commission the instrument and contact the manufacturer immediately.



Information

Avoid putting any mechanical loading on the electrical connections and on the cases. Connections must only be opened once the instrument has been depressurised and has cooled down.

Maximum permissible temperatures

- At the case: 70 °C [158 °F]
- At the process connection (version with FKM O-ring): -20 ... +125 °C [-4 ... +257 °F]

5. Commissioning and operation

5.1 Mechanical mounting

If the resistance thermometer is screwed directly into the process, the insertion length, along with the flow rate and viscosity of the process media can reduce the maximum probe load.

EN

The case must be grounded against electromagnetic fields and electrostatic charge. It is not necessary to connect the case separately to the equipotential bonding system, provided that it has a fixed and secure contact to the metal vessel, its components or pipes, and that these are connected to the equipotential bonding system.

In the event of non-metallic contact with the container or its structural parts or pipes, all electrically conductive thermometer components protruding into the hazardous area must be connected to an equipotential bonding system.

Tightening torques for compression fittings

Sealing	Turns	Max. pressure in bar [psi]
Stainless steel ferrule	1 ¼ ... 1 ½	100 [1,450]
Stainless steel bite-type ferrule	1 ¼ ... 1 ½	100 [1,450]
PTFE ferrule	1 ¼ ... 1 ½	8 [116]

5.2 First configuration

Check the radio unit for any damage that may have been caused. Obvious damage must be reported immediately.



First commission the radio unit without any measuring instrument connected. The configuration with the appropriate WIKA sensor must be carried out in advance, in order to avoid damage to the measuring instrument or the radio unit.

5. Commissioning and operation

5.3 Establishing the power supply

The power supply is established via the internal battery.

Connect battery

In as-delivered condition, the battery is not connected to the electronics.

Connecting the battery, see chapter 7.2 "Battery handling":

1. Open the case: As required by the version of the radio unit - a bayonet lock (plastic version) or a screw-on lid (metal version) is fitted. To do this, grip the upper and lower sides of the instrument with your hands and turn them as shown by the marking on the cover.
2. Plug in the battery connector and snap it into place (⇒ LED lights up).
3. Put the case on and close it. To do this, grip the upper and lower sides of the instrument with your hands and turn them in opposite directions as shown by the marking on the cover.

5.4 Connecting the radio unit to a measuring instrument

For the first 25 minutes after connecting the power supply, the LED function is activated.

LED colour	Mode	Meaning
Blue	Blinks once	Internal communication between radio and sensor PCBs
Cyan	ON for the duration of the join procedure	LoRaWAN [®] join procedure running
Cyan	Blinks once	LoRaWAN [®] join procedure successful
Red	Blinks twice	LoRaWAN [®] join procedure not successful
Red	Blinks twice	LoRaWAN [®] data transmission not successful (confirmed message)
Green	Blinks twice	LoRaWAN [®] data transmission successful (confirmed message)

Notes on the sending characteristics

- In order to achieve the best possible transmission quality, the radio link from the terminal device to the receiving gateway should be as free of barriers as possible.
- The signal strength is from slightly to severely affected by concrete walls, metal shielding, enclosures and hilly landscapes.
- For the best possible transmission performance of the antenna, no metal objects, such as pipelines, may be closer than 10 cm [3.94 in] to the antenna.
- With installation, pay attention to the sending characteristic of the instrument as well as the information from the following figure:

5. Commissioning and operation

Radiation characteristics

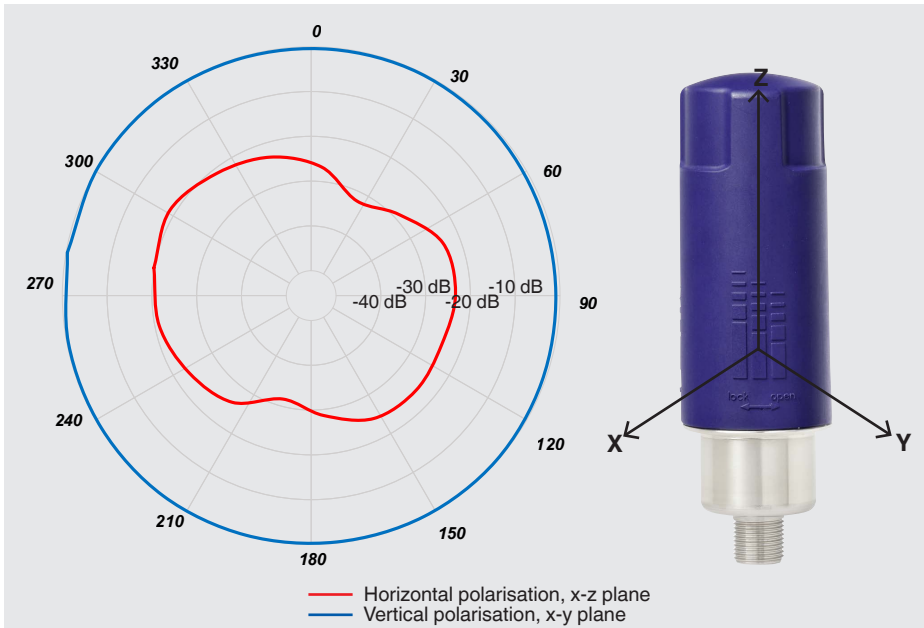

Information on the installation of the receiving gateway

Position the gateway in such a way that the transmission power of the instrument is optimally utilised. For this, the following recommendations should be observed:

- Depending on the application, a gateway for indoor or outdoor use should be selected.
- The radiation characteristics of the antenna should be taken into account when positioning the gateway.
- If the sensors are located on one level, vertical mounting of the LoRaWAN[®] antenna on the gateway is recommended. The location should ideally be in the middle of the area to be covered.
- If the sensors are located on several levels, the gateway should be placed in the middle of the building and the gateway antenna should be aligned horizontally.
- Another option is to place the gateway outside the building and align the antenna vertically. In this way, a sufficient radio connection can be established from the outside to several floors.
- In outdoor areas, ensure that the gateway is mounted at a sufficient height and is not covered by anything in the immediate vicinity. The higher the gateway is positioned, the further the LoRaWAN[®] connection reaches.

5. Commissioning and operation

5.5 “myWIKa wireless device” app



Via the “myWIKa wireless device” app and a Bluetooth® Low Energy connection, the functionality of the LoRaWAN® communication can be activated and deactivated through the mobile device. Furthermore, the instrument data and the current measured value can be read via the app. For this, follow the instructions on the screen.

EN

5.6 Battery status

The battery life is affected by factors such as the transmission rate, the spreading factor or the ambient temperature. The calculation of the value is based on a constant ambient temperature of 20 °C [68 °F] is assumed. The battery life is displayed as a percentage value over Bluetooth® in the advertising frame and transmitted via LoRaWAN®. At values below 20 % of the expected remaining service life a battery change is recommended. If the battery is completely discharged, no more values are transmitted via the radio unit.

5.7 Connecting the radio unit within an LPWAN

The WIKa radio unit can be connected via LoRaWAN® to an IIoT infrastructure. For this, the radio unit is connected to a LoRaWAN® gateway and the measured values are transferred to the IIoT infrastructure (e.g. cloud platform, PC, mobile device, etc.) at freely configurable intervals.

For the IIoT connection, all relevant data for registration and commissioning, as well as an interface specification for further processing of the data are provided, see the additional documentation “Special documentation for LoRaWAN® communication protocol, TRW”, 14617652.

The deployment package includes the following registration information:

- DevEUI (64-bit end device, unique identifier)
- AppEUI (64-bit unique application identifier)
- AppKey (128-bit key)

5. Commissioning and operation



With a customer-specific integration, the payload integration must be carried out by the customer in accordance with the additional documentation “Special documentation for LoRaWAN® communication specifications, model TRW” on the WIKA website.

EN

5.8 Alarm description

Three basic alarm types can be configured: alarm limit, alarm limit with delay, measuring signal change.

These alarms can be set using the “myWIKa wireless device” app via Bluetooth® or via a LoRaWAN® connection via the WIKa cloud.

For a customer connection without a WIKa app or WIKa cloud, the “Special documentation for LoRaWAN® communication specifications, model TRW” must be observed.

A combination of alarm functions is possible, e.g. alarm limit for rising and falling measured value to define an operating window for the application.

Alarm limit, rising measured value

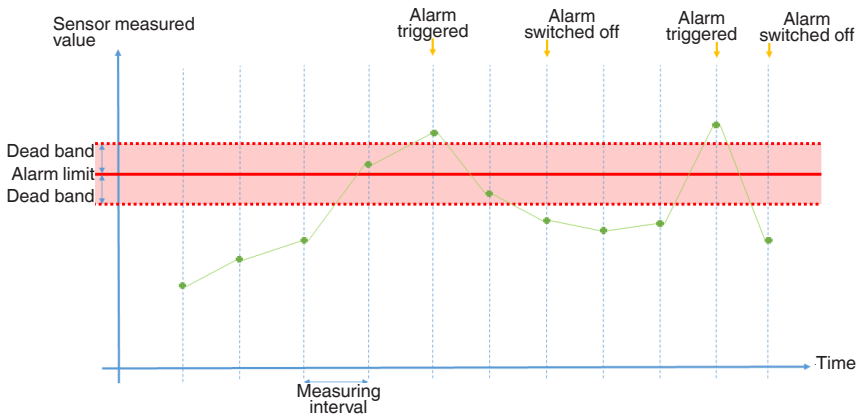

5. Commissioning and operation

EN

Alarm limit, falling measured value

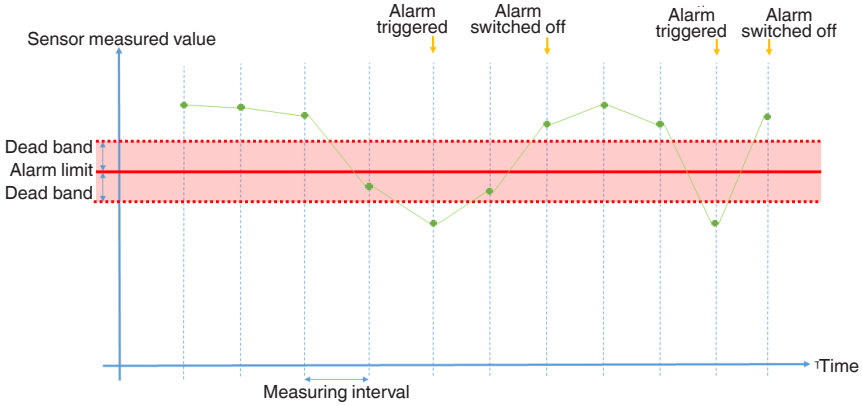

Alarm limit, rising measured value with delay

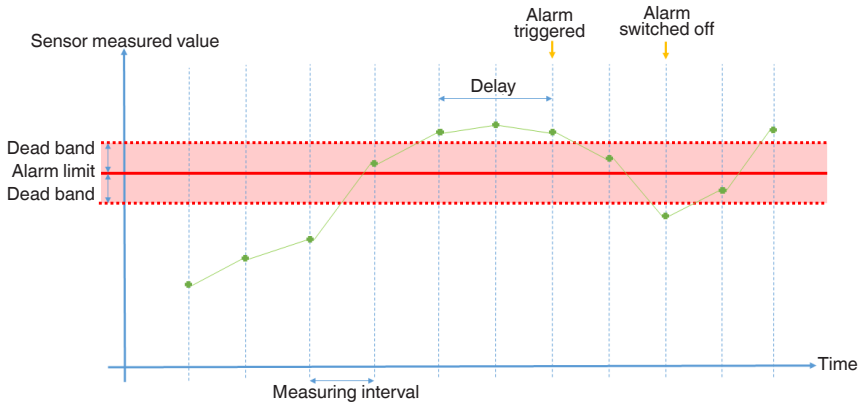

5. Commissioning and operation

Alarm limit, falling measured value with delay

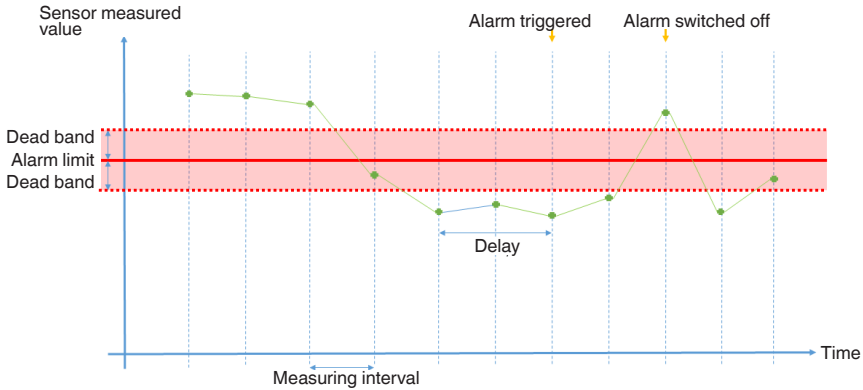

→ For decommissioning and if you intend to take the system out of operation for a longer period, see chapter .8.1 “Dismounting”.

Change in measured value (slope) falling

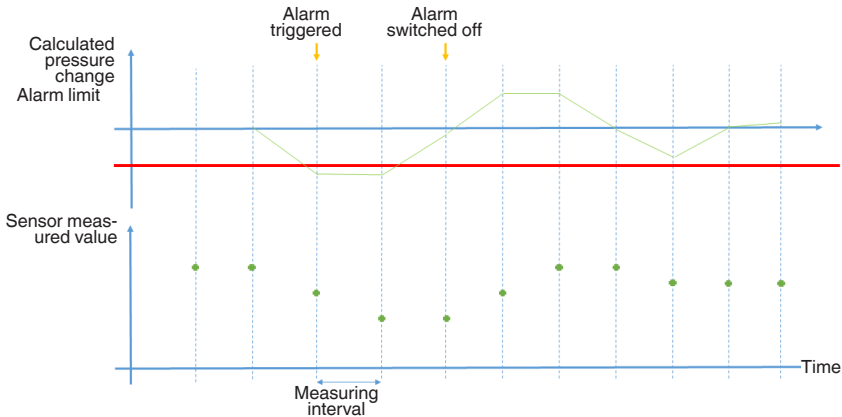

A heat input (e.g. heat flow from the process or radiant heat from the environment) that exceeds the permissible ambient temperature of the case is not permitted and must be prevented by suitable thermal decoupling or a sufficiently long neck tube or suitable on-site measures. The heat input must be determined by the user by calculation or measurement.

6. Faults

Personnel: Skilled personnel



CAUTION!

Physical injuries and damage to property and the environment

If faults cannot be eliminated by means of the listed measures, the instrument must be taken out of operation immediately.

- ▶ Ensure that no signal is transmitted anymore and protect against being put into operation accidentally.
- ▶ Contact the manufacturer.
- ▶ If a return is needed, please follow the instructions given in chapter 8 “Dismounting, return and disposal”.



For contact details, see chapter 1 „General information“ or the back page of the operating instructions.

Fault	Causes	Measures
Connection to the IIoT platform is not successful	Login credentials lost	Contact customer service
	Incorrect login credentials	Check using the supplied login credentials
	Customer firewall blocks interfaces	Contact the person responsible for infrastructure
	Instrument is outside the range of the gateway	Observe instructions in accordance with the operating instructions.
	Faulty commissioning or improper, unsuitable installation location	Observe instructions in accordance with the operating instructions
QR code is not readable	Unfavourable light and distance conditions	Optimisation by the operator

6. Faults

EN

Fault	Causes	Measures
No measured value transmission after previously unrestricted function	Battery empty	Change the battery, see chapter 7.2 "Battery handling"
	Incorrect battery replacement	Checking the battery change or battery charge status
	Instrument outside the range of the gateway	Observe instructions in accordance with the operating instructions, see chapter „Information on the installation of the receiving gateway“
	Damage due to improper use	Observe the intended use, see chapter 2.1 "Intended use"
	Changes in the infrastructure	Contact the person responsible for the infrastructure
No connection to gateway	Gateway is switched off	Switch the gateway on and ensure that a connection to the network server exists
Individual measured value not transmitted	Collision in the data transmission	Unavoidable! Adaptation of infrastructure possible
Bluetooth® transmission does not work	Battery not yet connected	Remove the case and connect the battery, see chapter 7.2 "Battery handling"
	Battery empty	For removing the case and changing the battery, see chapter 7.2 "Battery handling"
	Instrument out of range	Reduce the distance to the instrument
	Bluetooth® of the mobile device is not activated	Activate the Bluetooth® function of the mobile device
Mechanical damage	Improper handling	Replace instrument
	Impermissible loading at the installation location (e.g. fire).	
Pairing over Bluetooth® does not work	Improper handling (5x incorrect input of the key)	Carry out a battery reset and log in with the correct BLE key
		Contact the manufacturer

14642235.02.02/2024 EN/DE

7. Maintenance, cleaning and calibration

Personnel: Skilled personnel



For contact details, see chapter 1 „General information“ or the back page of the operating instructions.

7.1 Maintenance

Repairs must only be carried out by the manufacturer.

This does not apply to the battery, fuse or seal replacement.

Only use original parts, see chapter 10 “Accessories and spare parts”.

7.2 Battery handling

For battery replacement observe the following instructions:

- Only change the batteries in a dry environment.
- Do not use rechargeable batteries.
- Only use approved batteries, see chapter 7.2 “Battery handling”.
- Do not use power tools for screwing in.



During longer times of inactivity, remove the batteries from the instrument.

After changing the battery, the command “Battery changed” must be sent in the app “myWIKA wireless device” under Actions or alternatively via the cloud.



After executing the “Battery changed” command, do not disconnect the battery from the sensor for at least 24 hours.

7. Maintenance, cleaning and calibration

Removing the battery:



Procedure

1. Open the case top. Grip the upper and lower sides of the instrument with your hands and turn them in opposite directions.
2. Remove the case top upwards.
3. Pull the battery connector off.
4. Remove the battery.

Inserting the battery:



Procedure

1. Place the new battery in the holder.
 2. Connect the connector to the PCB.
 3. Replace the case top to close the sensor. Grip the upper and lower sides of the instrument with your hands and turn them in opposite directions to tighten.
- On closing the case top, ensure that the battery connection cables do not become pinched.

7.3 Cleaning



CAUTION!

Physical injuries and damage to property and the environment

Residual media can result in a risk to persons, the environment and equipment.

- ▶ Carry out the cleaning process in accordance with the manufacturer's instructions.



CAUTION!

Damage to property due to improper cleaning

Improper cleaning may lead to damage to the instrument.

- ▶ Do not use any aggressive cleaning agents.
- ▶ Do not use any hard or pointed objects for cleaning.
- ▶ Do not use any abrasive cloths or sponges.

1. Prior to cleaning, properly disconnect the instrument from the power supply and, if required, deactivate the data transmission from the radio unit during cleaning.
2. Clean the instrument with a moist cloth.

8. Dismounting, return and disposal

Personnel: Skilled personnel

8.1 Dismounting



WARNING!

Physical injuries and damage to property and the environment through residual media

Upon contact with hazardous media (e.g. oxygen, acetylene, flammable or toxic substances), harmful media (e.g. corrosive, toxic, carcinogenic, radioactive), and also with refrigeration plants and compressors, there is a danger of physical injuries and damage to property and the environment.

- ▶ Before storage of the dismantled instrument (following use) wash or clean it. Observe the information in the material safety data sheet for the corresponding medium.



DANGER!

Risk of burns

On contact, there is a risk of burns through hot surfaces.

- ▶ Let the instrument cool down sufficiently before dismantling it!

8. Dismounting, return and disposal



WARNING!

Physical injury

When dismounting, there is a danger from aggressive media and high pressures.

- ▶ Observe the information in the material safety data sheet for the corresponding medium.
- ▶ Only disconnect the resistance thermometer once the system has been depressurised!

EN

1. Loosen the instrument with a spanner, using the spanner flats.
2. Screw out the instrument by hand.



If the plug connection is disconnected, do not allow the electrical connection to come into contact with moisture!

For decommissioning and storage, observe the following:

- Reset personal passwords.
- Switch off the machine/plant properly.
- Remove the batteries or disconnect the voltage supply.

8.2 Return

Strictly observe the following when shipping the instrument:

- All instruments delivered to WIKA must be free from any kind of hazardous substances (acids, bases, solutions, etc.) and must therefore be cleaned before being returned, see chapter 7.3 “Cleaning”.
- When returning the instrument, use the original packaging or a suitable transport packaging.

To avoid damage:

1. Wrap the instrument in an anti-static plastic film. (for instruments with electrical components).
2. Place the instrument, along with the shock-absorbent material, in the packaging.
3. If possible, place a bag, containing a desiccant, inside the packaging.
4. Label the shipment as carriage of a highly sensitive measuring instrument.



Information on returns can be found under the heading “Service” on our local website (product return form).
Before returning, the data transmission of the radio unit must be deactivated.

8. Dismounting, return and disposal

8.4 Disposal

Incorrect disposal can put the environment at risk.

Dispose of instrument components and packaging materials in an environmentally compatible way and in accordance with the country-specific waste disposal regulations.



Do not dispose of with household waste. Ensure a proper disposal in accordance with national regulations.

Disposal of batteries

The separate collection and recycling of batteries makes an important contribution to protecting the environment and avoiding health hazards.



Batteries contain valuable raw materials such as iron, zinc, manganese or nickel that can be recovered.

9. Specifications

9. Specifications

Accuracy specifications

Overall accuracy	■ Measuring range ≤ 300 °C: +/- 1,4 °K
	■ Measuring range > 300 °C: +/- 2,9 °K

Reference conditions	Per IEC 62828-1
-----------------------------	-----------------

Measuring range

Temperature range ¹⁾	■ -196 ... +300 °C [-321 ... +572 °F]
	■ -50 ... +300 °C [-58 ... +572 °F]
	■ -50 ... +500 °C [-58 ... +932 °F]

Version with FKM O-ring	-20 ... +125 °C [-4 ... +257 °F]
-------------------------	----------------------------------

1) The temperature transmitter should therefore be protected from temperatures below -20 °C [-4 °F] and over +60 °C [+140 °F].

Process connection

Type of process connection	<ul style="list-style-type: none">■ G ¼ B■ G ⅜ B■ G ½ B■ ¼ NPT■ ½ NPT■ M12 x 1.5■ M20 x 1.5■ 7/16-20 UNF-2A■ without■ G ¼ B compression fitting (metal ferrule)■ G ⅜ B compression fitting (metal ferrule)■ G ½ B compression fitting (metal ferrule)■ ¼ NPT compression fitting (metal ferrule)■ ½ NPT compression fitting (metal ferrule)■ G ¼ B compression fitting (PTFE ferrule)■ G ⅜ B compression fitting (PTFE ferrule)■ G ½ B compression fitting (PTFE ferrule)■ ¼ NPT compression fitting (PTFE ferrule)■ ½ NPT compression fitting (PTFE ferrule)■ G ⅜ union nut, spring-loaded sensor (for additional thermowell)■ M24 x 1.5 female thread, spring-loaded sensor (for additional thermowell / neck tube)■ Tightening strap (for fitting on surface)
-----------------------------------	---

Sensor

Sensor diameter	■ 3 mm [0.12 in]
	■ 6 mm [0.24 in]

14642235.02.02/2024 EN/DE

9. Specifications

EN

Process connection

Insertion length ¹⁾	<ul style="list-style-type: none"> ■ 50 mm [1.97 in] ■ 75 mm [2.95 in] ■ 100 mm [3.94 in] ■ 120 mm [4.72 in] ■ 150 mm [5.91 in] ■ 200 mm [7.87 in] ■ 250 mm [9.84 in] ■ 300 mm [11.81 in] ■ 350 mm [13.78 in] ■ 400 mm [15.75 in]
	→ Other insertion lengths on request

Thermowell ²⁾

Connection to thermometer	<ul style="list-style-type: none"> ■ G 3/8 union nut, spring-loaded sensor ■ M24 x 1,5 female thread, spring-loaded sensor
---------------------------	--

- 1) The first 60 mm [2.59 in] of the probe tip must not be bent. At the transition to the transmitter, bending is allowed at a distance of 30 mm [1.18 in] from the case. The sheathed resistance thermometer may be bent with a radius of 5 times the diameter.
- 2) Various thermowells/protection tubes can be combined with the TRW.

Thermowell/Protection tube examples for sanitary applications

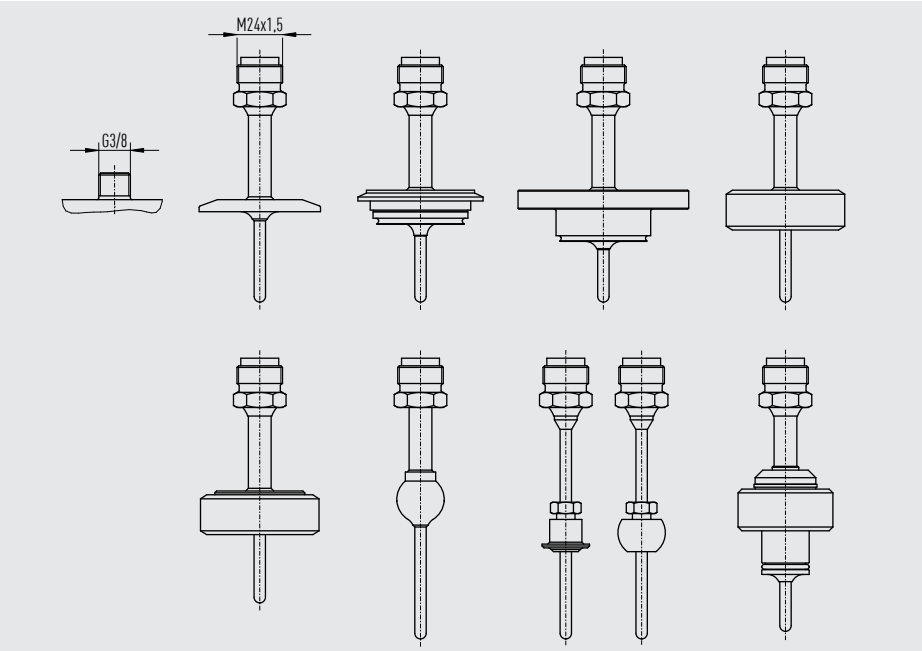

→ For details, see data sheet TW 95.22

14642235.02.02/2024 EN/DE

Radio standard

LoRaWAN®

Specification	LoRaWAN® 868 MHz EU	
Protocol version	1.0.3	
Protocol functions	<ul style="list-style-type: none"> ■ Registration ■ Configuration ■ Sending measured values ■ Alarm management ■ Battery status 	
Frequency range	863 ... 870 MHz	
Range in free field	Typically 10 km [6 mi] → Depending on the ambient conditions, such as topography and building structures.	
Antenna	PCB antenna, internal	
Channel spacing	200 kHz	
Bandwidth	125 kHz	
Max. transmission power	14 dBm	
Transmission interval	Standard	30 minutes
	Minimum	1 minute (maximum transmission rate limited per ETSI EN 300 220) → Limitation of the transmission interval in accordance with ETSI EN 300 220 possible. The maximum transmission frequency and duty cycle comply with the standard ETSI EN300 220.
	Maximum	7 days
Security	Full end-to-end encryption per AES-128 → For details on security, see website: https://loro-alliance.org	

Bluetooth®

Version	Bluetooth® 5.0 or newer → Compatible with all Bluetooth® Low Energy versions 4.2 or newer	
Functions	<ul style="list-style-type: none"> ■ Registration ■ Configuration ■ Sending measured values ■ Alarm management ■ Battery status ■ Data logger 	
Frequency range	2.4 GHz	

9. Specifications

EN

Radio standard	
Range in free field	Typically 10 m [32.8 ft], free field → Depending on the ambient conditions, such as topography and building structures.
Max. transmission power	4 dBm
Antenna	Chip antenna, internal
Transmission interval	1.25 seconds
	→ Update of the measured value only occurs in the set measuring interval.

→ For further information on the radio protocols, see www.wika.com.

Voltage supply and performance data		
Battery pack	Lithium thionyl chloride battery (model Tadiran SL860/S and hybrid layer capacitor (model Tadiran HLC1020L) as an assembly with connection cable assembled, see chapter 10 "Accessories and spare parts".	
Battery voltage	DC 3.6 V	
Battery life	> 10 years (measuring and transmission interval 1 hour, spreading factor 10)	
	→ At reference conditions	
Current supply	Max. 50 mA	
Measuring interval	Standard	1 minute
	Minimum	10 seconds → Smaller measuring intervals on request
	Maximum	7 days

Material	
Materials (wetted)	
Sheath material	<ul style="list-style-type: none"> ■ Stainless steel 1.4571 ■ Stainless steel 316L
Process connection	<ul style="list-style-type: none"> ■ Stainless steel 1.4571 ■ Stainless steel 316L

14642235.02.02/2024 EN/DE

9. Specifications

Operating conditions

Ambient temperature range	-20 ... +60 °C [-4 ... +140 °F] ¹⁾
Storage temperature range	-40 ... +70 °C [-40 ... +158 °F] Version with FKM O-ring -20 °C [-4 °F]
Altitude in accordance with EN 61010-1	Max. 2,000 m [6.56 ft] above sea level
Relative humidity	20 ... 90 %, non-condensing
Maximum operating pressure ^{2) 3)}	
With sensor diameter 3 mm [0.12 in]	140 bar [2,030 psi]
With sensor diameter 6 mm [0.24 in]	270 bar [3,916 psi]
Permissible pollution degree per EN 61010-1	2
Vibration resistance per IEC 60068-2-6	5 g (10 ... 200 Hz) ⁴⁾
Shock resistance per IEC 60068-2-27	10 g, 11 ms
Free fall per IEC 60068-2-31	Individual packaging 1.2 m [3.94 ft]
Ingress protection per IEC/EN 60529	<ul style="list-style-type: none"> ■ IP65 ■ IP67
Weight	Approx. 0.05 ... 0.7 kg [0.11 ... 1.54 lbs] - depending on version

1) Version -40 ... +60°C [-40 ... +140 °F] on request:

2) Dependent on the instrument version. In combination with an additional thermowell, this determines the maximum operating pressure

3) Reduced operating pressure when using a compression fitting: Stainless steel: max. 100 bar [1,450 psi] / PTFE = max. 8 bar [116 psi]

4) Dependent on the instrument version. Specification applies to instrument versions without neck tube and for a maximum insertion length < 100 mm [3.94 in].
For insertion lengths > 100 mm [3.94 in] with limitation to 3 g max.

Alarms

Alarms

Various alarms can be set.
→ See operating instructions for details

9. Specifications

Approvals

Logo	Description	Country
	EU declaration of conformity	European Union
	RED - Radio Equipment Directive EN 61326 emission (group 1, class B) and immunity (industrial application) This wireless device may be used without restriction in the member states of the EU and in the countries UK, CH, NO, LI. Use in other countries is not permitted.	
	RoHS directive	

EN

Certificates

Certificates	
Certificates	<ul style="list-style-type: none">■ 2.2 test report per EN 10204 (e.g. state-of-the-art manufacturing, material proof)■ 3.1 inspection certificate per EN 10204 (e.g. material proof for wetted metal parts)

→ For approvals and certificates, see website

9. Specifications

Dimensions in mm [in]

Process connection with parallel thread (or without process connection)

EN	Legend:	Ød	Sensor diameter	
	A	Insertion length	X	Height process connection
	L1	Thread length	1/4 NPT = 15 mm [0.59 in]	
	N (MH)	Neck length	1/2 NPT = 19 mm [0.75 in]	

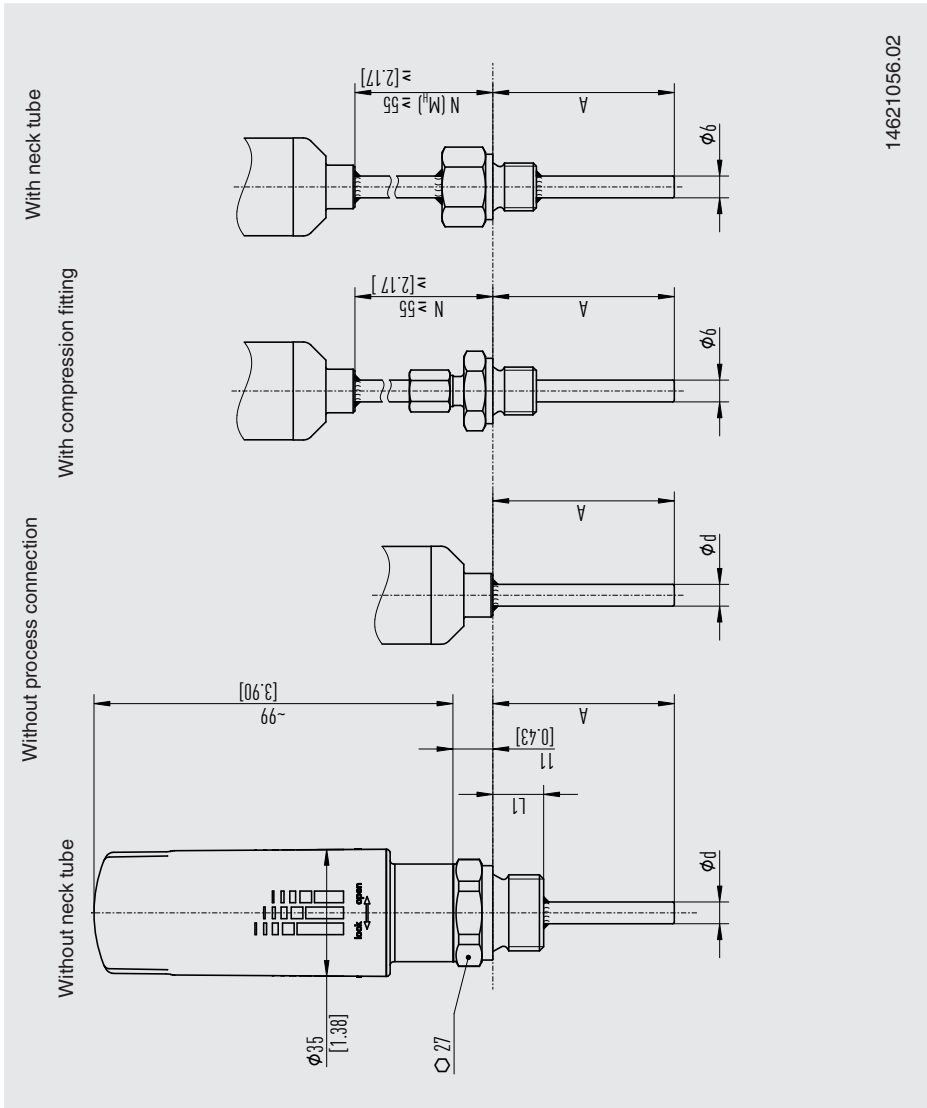

14621056.02

14642235.02 02/2024 EN/DE

9. Specifications

Process connection with parallel thread (7/16-20 UNF-2A) and O-ring

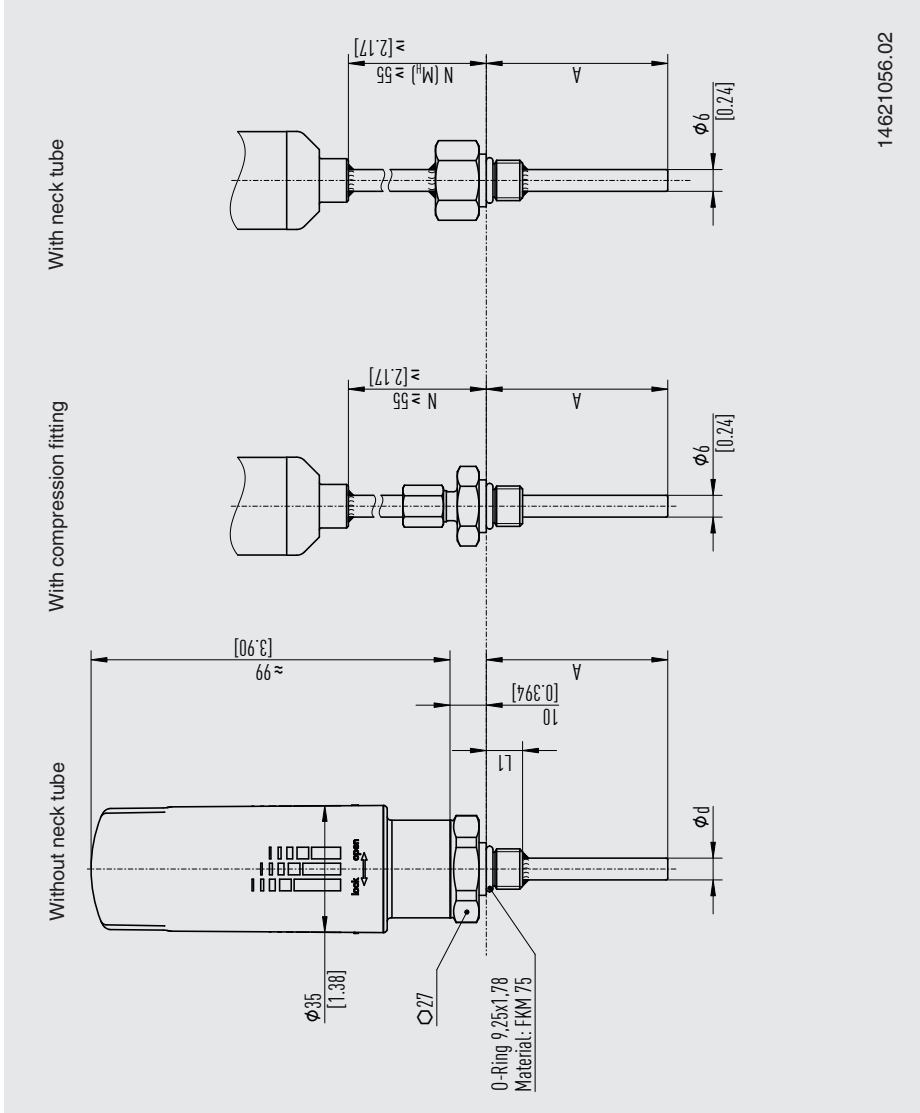

EN

14642235.02 02/2024 EN/DE

The FKM O-ring must be protected from temperatures lower than $-20\text{ }^\circ\text{C}$ [$-4\text{ }^\circ\text{F}$] and higher than $125\text{ }^\circ\text{C}$ [$257\text{ }^\circ\text{F}$].

9. Specifications

Process connection with tapered thread

With neck tube

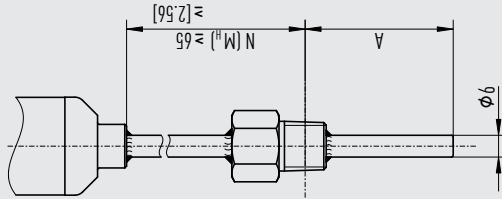

With compression fitting

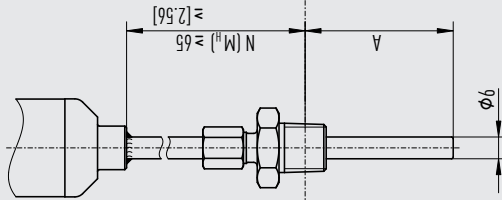

Without neck tube

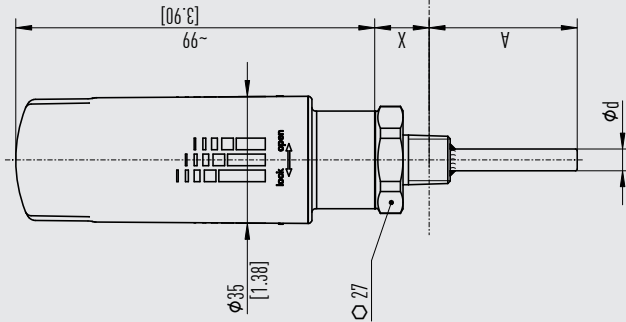

14621056.02

At a process temperature of $> 150\text{ }^{\circ}\text{C}$ [$302\text{ }^{\circ}\text{F}$], a neck length N (MH) of 70 mm [2.76 in] is necessary, otherwise N (MH) selectable (55 mm [2.17 in], 65 mm [2.56 in] or 70 mm [2.76 in]).

14642235.02 02/2024 EN/DE

9. Specifications

Spring-loaded process connection

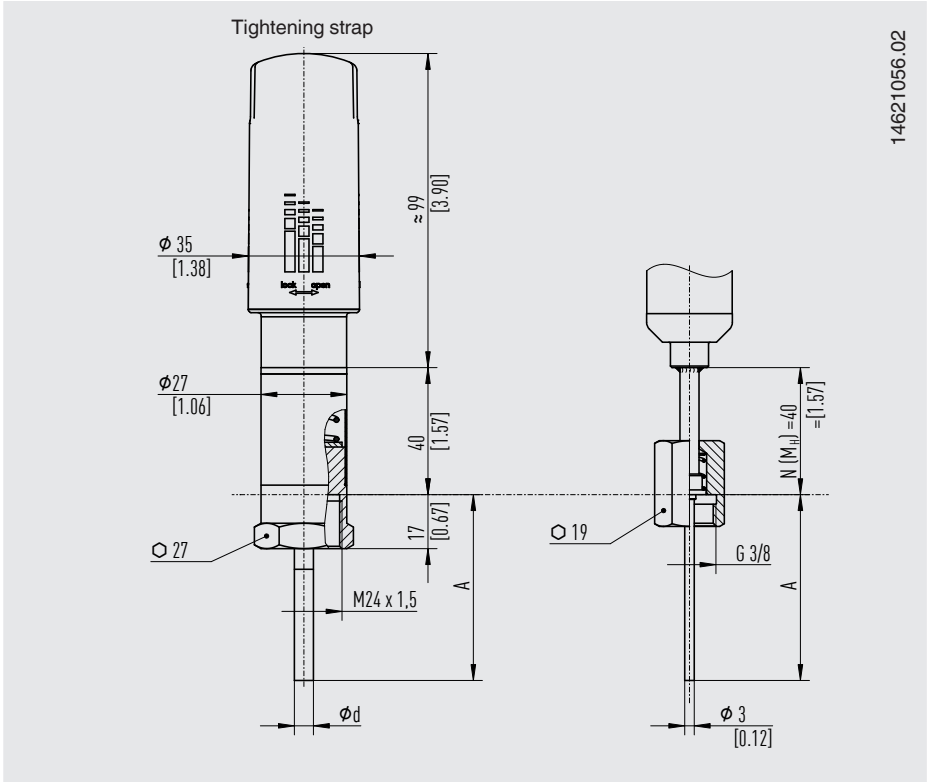

14621056.02

EN

The neck length depends on the intended use. Usually an isolation is bridged by the neck tube. Also, in many cases, the neck tube serves as a cooling element in order to protect a possible built-in transmitter from high medium temperatures.

14642235.02.02/2024 EN/DE

9. Specifications

Process connection for surface measurement

EN

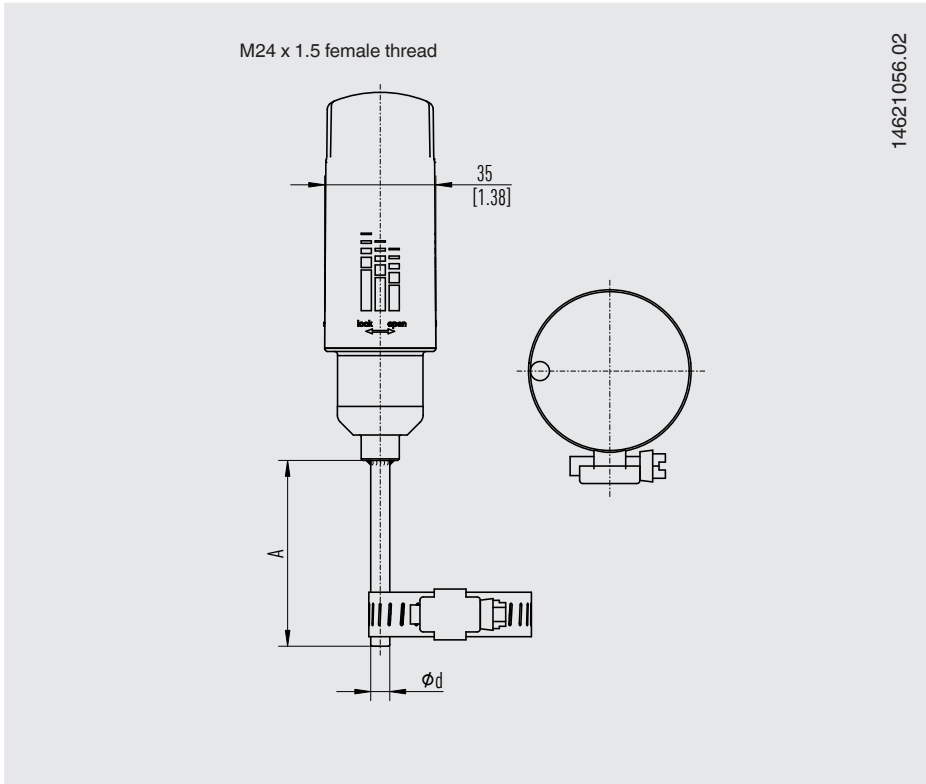

→ Other process connections, see data sheet TW 95.22

Tightening strap for pipe diameter

11 ... 15 mm [0.43 ... 0.59 in]

13 ... 25 mm [0.51 ... 0.98 in]

23 ... 62 mm [0.91 ... 2.44 in]

60 ... 93 mm [2.36 ... 3.66 in]

91 ... 125 mm [3.58 ... 4.92 in]

123 ... 158 mm [4.84 ... 6.22 in]

→ Other sizes on request: 159 ... 2,500 mm [6.26 ... 98.43 in]

14642235.02 02/2024 EN/DE

10. Accessories and spare parts

10. Accessories and spare parts

Accessories

Model	Order number
LoRaWAN® gateway, preconfigured for WIKA network server	
Gateway for indoor use	On request
Gateway for outdoor use	On request

EN

Spare parts

Model	Description	Order number
Battery	Lithium thionyl chloride battery and hybrid layer capacitor (model Tadiran HLC1020L) as an assembly with connection cable assembled.	14392747
	Model Tadiran SL860/S 2,4 Ah	

Inhalt

1. Allgemeines	47
1.1 Abkürzungen, Definitionen	48
1.2 Symbolerklärung	48
2. Sicherheit	49
2.1 Bestimmungsgemäße Verwendung	49
2.2 Fehlgebrauch	50
2.3 Personalqualifikation	51
2.4 Beschilderung, Sicherheitskennzeichnungen	51
2.5 Inhalt des QR-Codes auf dem Typenschild (Beispiel)	52
2.6 Freigegebene Batterien	53
2.7 Sicherheitsbeschreibung für Stromversorgung	53
2.8 Datenübertragungssicherheit	54
3. Transport, Verpackung und Lagerung	55
3.1 Transport	55
3.2 Verpackung und Lagerung	56
4. Aufbau und Funktion	57
4.1 Übersicht	57
4.2 Lieferumfang	57
4.3 Beschreibung	58
4.4 Funktionsprinzip	58
5. Inbetriebnahme und Betrieb	59
5.1 Mechanische Montage	61
5.2 Erste Konfiguration	61
5.3 Herstellen der Energieversorgung	62
5.4 Verbinden der Funkeinheit mit einem Messgerät	62
5.5 App „myWIKA wireless device“	64
5.6 Batteriestatus	64
5.7 Anbindung der Funkeinheit in ein LPWAN	64
5.8 Alarmbeschreibung	65
6. Störungen	68
7. Wartung	70
7.1 Wartung	70
7.2 Batteriehandhabung	70
7.3 Reinigung	72

DE

8. Demontage, Rücksendung und Entsorgung	73
8.1 Demontage	73
8.2 Rücksendung	74
8.3 Entsorgung	74
9. Technische Daten	76
10. Zubehör und Ersatzteile	87
Annex: EU declaration of conformity	88

1. Allgemeines

- Das in der Betriebsanleitung beschriebene Gerät wird nach dem aktuellen Stand der Technik konstruiert und gefertigt. Alle Bauteile unterliegen während der Herstellung strengen Qualitäts- und Umweltkriterien. Unsere Managementsysteme sind nach ISO 9001 und ISO 14001 zertifiziert.
- Diese Betriebsanleitung gibt wichtige Hinweise zum Umgang mit dem Gerät. Voraussetzung für sicheres Arbeiten ist die Einhaltung aller angegebenen Sicherheitshinweise und Handlungsanweisungen.
- Die für den Einsatzbereich des Geräts geltenden örtlichen Unfallverhütungsvorschriften und allgemeinen Sicherheitsbestimmungen einhalten.
- Die Betriebsanleitung ist Produktbestandteil und muss in unmittelbarer Nähe des Geräts für das Fachpersonal jederzeit zugänglich aufbewahrt werden. Betriebsanleitung an nachfolgende Bediener oder Besitzer des Geräts weitergeben.
- Das Fachpersonal muss die Betriebsanleitung vor Beginn aller Arbeiten sorgfältig durchgelesen und verstanden haben.
- Bei unterschiedlicher Auslegung der übersetzten und der englischen Betriebsanleitung ist der englische Wortlaut maßgebend.
- In diesem Dokument wird zur besseren Lesbarkeit das generische Maskulinum verwendet. Weibliche und anderweitige Geschlechteridentitäten werden dabei ausdrücklich eingeschlossen.
- Es gelten die allgemeinen Geschäftsbedingungen in den Verkaufsunterlagen.
- Technische Änderungen vorbehalten.
- Weitere Informationen:
 - Internet-Adresse: www.wika.de / www.wika.com
 - Zugehöriges Datenblatt: TE 63.04
Special documentation for LoRaWAN®
communication protocol, model TRW,
14617652
 - Zusatzdokumentation
 - Kontakt: Tel.: +49 9372 132-0

1. Allgemeines

1.1 Abkürzungen, Definitionen

■	Aufzählungssymbol
▶	Handlungsanweisung
1. ... x.	Handlungsanweisung Schritt für Schritt durchführen
⇒	Ergebnis einer Handlungsanweisung
→	Siehe ... Querverweise
RTD	Widerstandsthermometer
PBT	Polybutylenterephthalat

DE

1.2 Symbolerklärung



GEFAHR!

... weist auf eine unmittelbar gefährliche Situation hin, die zum Tod oder zu schweren Verletzungen führt, wenn sie nicht gemieden wird.



WARNUNG!

... weist auf eine möglicherweise gefährliche Situation hin, die zum Tod oder zu schweren Verletzungen führen kann, wenn sie nicht gemieden wird.



VORSICHT!

... weist auf eine möglicherweise gefährliche Situation hin, die zu geringfügigen oder leichten Verletzungen bzw. Sach- und Umweltschäden führen kann, wenn sie nicht gemieden wird.



GEFAHR!

... kennzeichnet Gefährdungen durch elektrischen Strom. Bei Nichtbeachtung der Sicherheitshinweise besteht die Gefahr schwerer oder tödlicher Verletzungen.



GEFAHR!

... weist auf eine möglicherweise gefährliche Situation im explosionsgefährdeten Bereich hin, die zum Tod oder zu schweren Verletzungen führen kann, wenn sie nicht gemieden wird.



WARNUNG!

... weist auf eine möglicherweise gefährliche Situation hin, die durch heiße Oberflächen oder Flüssigkeiten zu Verbrennungen führen kann, wenn sie nicht gemieden wird.



Information

... hebt nützliche Tipps und Empfehlungen sowie Informationen für einen effizienten und störungsfreien Betrieb hervor.

2. Sicherheit

2.1 Bestimmungsgemäße Verwendung

Das Widerstandsthermometer TRW überträgt seinen Temperaturwert an ein übergeordnetes System. Das Gerät kann überall dort eingesetzt werden, wo ein RTD-Wert digitalisiert und über Bluetooth® Low Energy oder LoRaWAN® zur Verfügung gestellt wird. Eine Fernüberwachung des RTD-Werts kann über eine webbasierte Plattform erfolgen.

Das Gerät ist ausschließlich für den hier beschriebenen bestimmungsgemäßen Verwendungszweck konzipiert und konstruiert und darf nur dementsprechend verwendet werden.

Die technischen Spezifikationen in dieser Betriebsanleitung sind einzuhalten siehe Kapitel 9 „Technische Daten“. Eine sachgemäße Handhabung und das Betreiben des Geräts innerhalb der technischen Spezifikationen wird vorausgesetzt. Andernfalls ist eine sofortige Stilllegung und Überprüfung durch einen autorisierten WIKA-Servicemitarbeiter erforderlich.

Elektronische Geräte mit erforderlicher Sorgfalt behandeln (vor Nässe, Stößen, starken Magnetfeldern, statischer Elektrizität und extremen Temperaturen schützen, keine Gegenstände in das Gerät bzw. Öffnungen einführen).

Ansprüche jeglicher Art aufgrund von nicht bestimmungsgemäßer Verwendung sind ausgeschlossen.

2.2 Fehlgebrauch



WARNUNG!

Gefahr durch entstehendes Feuer oder Explosion

Die Verwendung nicht freigegebener Batterien kann durch entehendes Feuer zu Schäden an Personen, am Gerät und der Umgebung führen.

- ▶ Nur freigegebene Batterien verwenden, siehe Kapitel 9 „Technische Daten“.

DE



Die Fernüberwachungsfunktion darf nicht für Regel- bzw. Steuerungszwecke genutzt werden, da nicht ausgeschlossen werden kann, dass es bei der Funkübertragung zum Verlust von Datenpaketen kommen kann.

Das LoRaWAN[®]-Signal darf nur eingeschränkt für mobile Anwendungen eingesetzt werden. Dies gilt insbesondere für hohe Spreizfaktoren.

- Dieses Gerät ist nicht für den Einsatz in explosionsgefährdeten Bereichen zugelassen.
- Für Anwendungen mit direkter Lebensmittelberührung ist dieses Gerät nicht geeignet.
- Jede über die bestimmungsgemäße Verwendung hinausgehende oder andersartige Benutzung gilt als Fehlgebrauch.
- Eigenmächtige Umbauten am Gerät unterlassen.
- Dieses Gerät nicht in Sicherheits- oder in Not-Aus-Einrichtungen benutzen.

2.3 Personalqualifikation



Die in dieser Betriebsanleitung beschriebenen Tätigkeiten nur durch Fachpersonal nachfolgend beschriebener Qualifikation durchführen lassen.

Fachpersonal

Das vom Betreiber autorisierte Fachpersonal ist aufgrund seiner fachlichen Ausbildung, seiner Kenntnisse der Mess- und Regelungstechnik und seiner Erfahrungen sowie Kenntnis der landesspezifischen Vorschriften, geltenden Normen und Richtlinien in der Lage, die beschriebenen Arbeiten auszuführen und mögliche Gefahren selbstständig zu erkennen.

DE

2.4 Beschilderung, Sicherheitskennzeichnungen

Die Beschilderung, Sicherheitskennzeichnungen sind lesbar zu halten.

Typenschild (Beispiel)

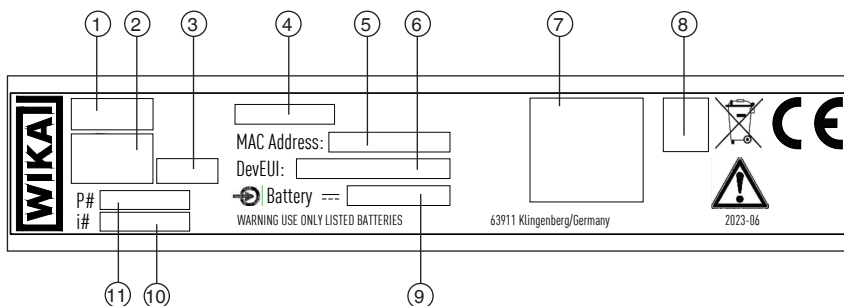

- ① Typ
- ② Funkstandards (für LoRaWAN[®] mit Angabe des „Regional Parameter WAN“)
- ③ Funkfrequenz
- ④ Umgebungstemperaturbereich
- ⑤ MAC-Adresse
- ⑥ DevEUI (nicht bei Bluetooth[®])
- ⑦ QR-Code nach LoRa Alliance[®]-Spezifikation
- ⑧ Bluetooth[®]
- ⑨ Versorgungsspannung
- ⑩ Seriennummer
- ⑪ Artikelnummer

2. Sicherheit

Symbole



Vor Montage und Inbetriebnahme des Geräts unbedingt die Betriebsanleitung lesen!



Nicht mit dem Hausmüll entsorgen. Für eine geordnete Entsorgung nach nationalen Vorgaben sorgen.

DE



Gleichspannung

2.5 Inhalt des QR-Codes auf dem Typenschild (Beispiel)



LW:D0:70B3D597B0000002:70B3D597B0004D71:02A30002:S1A01FZFCOJ6:PD1883F69EBE3:CC9B3

Inhalt	Identifizier	Beispiel	Kommentar
SchemaID	-	D0	-
JoinEUI (64 -bit)	-	70B3D597B0000002	JoinEUI = AppEUI
DevEUI (64-bit)	-	70B3D597B0004D71	-
ProfileID	-	02A30002	02A3 = VendorID WIKA; 0002 letzte 4 Stellen der JoinEUI
SerNum	S	1A01FZFCOJ6	Alphanumerische WIKA Seriennummer (11-stellig)
Proprietary	P	D1883F69EBE3	Bluetooth® MAC-Address: D1:88:3F:69:EB:E3
Checksum	C	C9B3	-

2.6 Freigegebene Batterien



VORSICHT!

Körperverletzungen, Sach- und Umweltschäden

Lithium-Thionylchlorid-Batterien sind nicht wiederaufladbar. Unsachgemäße Handhabung kann zu Leckagen oder zum Ausströmen verdampfter Elektrolytdämpfe führen und einen Brand oder eine Explosion verursachen.

- ▶ Die Batterie nicht öffnen.
- ▶ Die Batteriezellen nicht beschädigen.
- ▶ Die positiven und negativen Anschlüsse nicht mit Leitern kurzschließen.
- ▶ Die Polarität nicht umpolen.
- ▶ Die Batterie keiner übermäßigen mechanischen Belastung aussetzen.
- ▶ Die Batterie nicht mit Wasser oder Kondenswasser in Berührung bringen.
- ▶ Die Batterie nicht erhitzen, löten oder mit Feuer in Berührung bringen.
- ▶ Keine Akkumulatoren (wiederaufladbare Batterien) verwenden.
- ▶ Keine beschädigten Batterien verwenden.

Um eine einwandfreie Funktion und die bestmögliche Leistung zu gewährleisten, nur die aufgelistete Batterie verwenden, siehe Kapitel 10 „Zubehör und Ersatzteile“.

Batterie

Batteriepack

Lithium-Thionylchlorid-Batterie und Hybrid Layer Capacitor (Typ Tadiran HLC1020L) als Zusammenbau mit Anschlusskabel konfektioniert.

Typ Tadiran SL860/S

Bei Ausführung mit Batterie nur die geeigneten Gehäuse verwenden, siehe Kapitel 5.3 „Herstellen der Energieversorgung“ und 9 „Technische Daten“.

2.7 Sicherheitsbeschreibung für Stromversorgung

Temperaturbereich	-20 ... +60 °C [-4 ... +140 °F]
Spannungsversorgung Batterie	3,6 V
Stromaufnahme	Max. 250 mA
Max. Höhenlage	2.000 m [6561.68 ft]

2.8 Datenübertragungssicherheit

LoRaWAN®

Die LoRaWAN®-Übertragung verwendet das kryptografische Prinzip der AES-Verschlüsselung in Kombination mit mehreren Betriebsarten: für eine sichere Datenübertragung, CMAC2 für den Integritätsschutz und CTR3 für die Verschlüsselung. Jedes LoRaWAN®-Gerät wird mit einem einzigartigen 128-Bit-AES-Schlüssel (AppKey) und einem weltweit einzigartigen Identifikator (EUI-64-basiertes DevEUI) personalisiert, die beide während des Geräteauthentifizierungsprozesses verwendet werden.

→ Weitere Details können im offiziellen LoRaWAN® Security White Paper von der LoRa Alliance® nachgelesen werden, siehe <https://loro-alliance.org>.

Bluetooth® Low Energy

Bluetooth® Low Energy kommuniziert im lizenzfreien 2,4 GHz ISM-Band und ist ein global einheitlicher energieeffizienter Funkstandard. Bluetooth® Low Energy verwendet 40 Kanäle zwischen 2,402 GHz und 2,480 GHz. Die Verschlüsselung erfolgt mithilfe des AES 128 Encryption-Algorithmuses in Kombination mit einer verteilten Schlüsselauswechslung.

Die Funkeinheit überträgt als Broadcast Message auf den Advertising-Kanälen 37, 38 und 39 neben dem Gerätenamen und dem Batterieladezustand optional den Messwert. Über eine Punkt-zu-Punkt-Verbindung stehen weitere Informationen und ausführliche Konfigurations- und Befehlsmöglichkeiten zur Verfügung.



Das Pairing wird über eine Passkey-Entry-Methode hergestellt und verlangt die Eingabe eines Sicherheitscodes. Erst nach erfolgtem Pairing kann auf Geräte-Einstellungen zugegriffen werden. Der Pairing Key ist für jedes Gerät individuell eingestellt und wird mit dem Quick-Start-Guide dem Kunden zur Verfügung gestellt. Zur individuellen Vergabe kann der Pairing Key vom Nutzer über die App konfiguriert werden.

Wird der Sicherheitscode 5-mal falsch eingegeben, ist das Gerät für die Verbindung mit diesem Code gesperrt. Nach dem Entnehmen der Batterie sind wieder 5 Versuche verfügbar. Sollte das aus technischen Gründen nicht möglich sein, da z. B. der Sensor zum Öffnen des Gehäuses nicht erreichbar ist, den Technischen Support kontaktieren.

3. Transport, Verpackung und Lagerung

3.1 Transport



WARNUNG!

Beschädigungen von Akkus und Batterien durch unsachgemäßen Transport

Bei unsachgemäßem Transport von losen bzw. ausgebauten Akkus und Batterien können diese explodieren, brennen oder auslaufen.

- ▶ Offene Kontakte abkleben und die Akkus bzw. die Batterien so verpacken, dass sie sich nicht in der Verpackung bewegen (Kurzschlüsse verhindern).
- ▶ Beim Transport vorsichtig vorgehen und die Symbole auf der Verpackung beachten.



VORSICHT!

Beschädigungen durch unsachgemäßen Transport

Bei unsachgemäßem Transport können Sachschäden entstehen.

- ▶ Bei Abladen der Packstücke bei Anlieferung sowie innerbetrieblichem Transport vorsichtig vorgehen und die Symbole auf der Verpackung beachten.
- ▶ Bei innerbetrieblichem Transport die Hinweise im Kapitel 3.2 „Verpackung und Lagerung“ beachten.

Gerät auf eventuell vorhandene Schäden untersuchen.

Bei Schäden Gerät nicht in Betrieb nehmen und unverzüglich Kontakt mit dem Hersteller aufnehmen.

Wird das Gerät von einer kalten in eine warme Umgebung transportiert, kann durch Kondensatbildung eine Störung der Gerätefunktion eintreten. Vor einer erneuten Inbetriebnahme die Angleichung der Gerätetemperatur an die Raumtemperatur abwarten.

Beim Versand des Geräts unbedingt beachten:

Alle an WIKA gelieferten Geräte müssen frei von Gefahrstoffen (Säuren, Laugen, Lösungen, etc.) sein und sind daher vor der Rücksendung zu reinigen.

Die Batterie vor der Rücksendung entfernen.

Die enthaltenen Lithium-Ionen-Akkus oder Lithium-Metall-Batterien unterliegen den Anforderungen des Gefahrgutrechts. Beim Versand sind besondere Anforderungen an Verpackung und Kennzeichnung zu beachten. Hier muss bei der Vorbereitung des Versandstücks ein Gefahrgut-Experte hinzugezogen werden. Keine beschädigten oder defekte Akkus versenden. Offene Kontakte abkleben und den Akku so verpacken, dass er sich nicht in der Verpackung bewegt bzw. Kurzschlüsse verhindert werden. Die unter-

3. Transport, Verpackung und Lagerung

schiedlichen gefahrgutrechtlichen Vorgaben der jeweiligen Verkehrsträger und auch eventuelle weiterführende nationale Vorschriften beachten.

3.2 Verpackung und Lagerung

Verpackung erst unmittelbar vor der Montage entfernen.

Die Verpackung aufbewahren, denn diese bietet bei einem Transport einen optimalen Schutz (z. B. wechselnder Verwendungsort, Reparatursendung).

DE

Zulässige Bedingungen am Lagerort:

- Lagertemperatur: -40 ... +70 °C [-32 ... +158 °F]
- Feuchte: 35 ... 85 % relative Feuchte (keine Betauung)

Folgende Einflüsse vermeiden:

- Direktes Sonnenlicht oder Nähe zu heißen Gegenständen
- Mechanische Vibration, mechanischer Schock (hartes Aufstellen)
- Ruß, Dampf, Staub und korrosive Gase
- Explosionsgefährdete Umgebung, entzündliche Atmosphären

Das Gerät in der Originalverpackung an einem Ort lagern, der die zuvor aufgelisteten Bedingungen erfüllt. Bereits in Betrieb genommene Geräte sind vor der Einlagerung zu reinigen, siehe Kapitel 7.3 „Reinigung“.

Wenn die Originalverpackung nicht vorhanden ist, dann das Gerät wie folgt verpacken und lagern:

1. Die Batterie dekontaktieren.
2. Das Gerät in eine antistatische Plastikfolie einhüllen.
3. Das Gerät in der Verpackung platzieren und gleichmäßig dämmen.
4. Bei längerer Einlagerung (mehr als 30 Tage) einen Beutel mit Trocknungsmittel der Verpackung beilegen.

4. Aufbau und Funktion

4.1 Übersicht

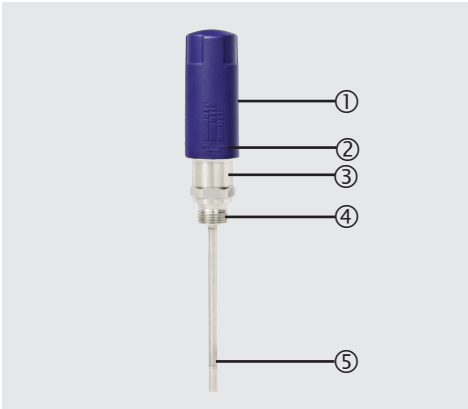

- ① Gehäuseoberteil (abnehmbar)
- ② Batteriefach, Stecker der Stromversorgung
- ③ Gehäuse mit Typenschild
- ④ Prozessanschluss
- ⑤ Schutzrohr

4.2 Lieferumfang

- Gerät Typ TRW
- Betriebsanleitung
- Quick-Start-Guide mit Zugangsdaten für die Inbetriebnahme (roter Umschlag)
- Batterie im Gerät

Lieferumfang mit dem Lieferschein abgleichen.

4.3 Beschreibung

Die Funkeinheit wurde entwickelt, um Sensorsignale drahtlos zu übertragen. Das Gerät wird an einen Sensor angeschlossen und nimmt von diesem Messwerte entgegen. Diese Werte werden im jeweiligen Funkprotokoll zur Verfügung gestellt. Die Funkübertragung erfolgt entweder via LoRaWAN[®] basierend auf der LPWAN-Technologie („Low Power Wide Area Network“), um hohe Übertragungreichweiten und eine lange Batterielebensdauer zu ermöglichen, oder über Bluetooth[®] Low Energy. Das Gerät wird über eine Batterie mit Strom versorgt. Die Funkeinheit erfüllt sämtliche sicherheitstechnischen Anforderungen einschlägiger Normen und Vorschriften der Funkanlagenrichtlinie zur Datenkommunikation. Die Funkeinheit ist ein Produkt, das hohe Anforderungen erfüllt und mit ausgezeichneter Zuverlässigkeit Daten übermittelt. Die Übertragung des Sensorsignals in die IIoT-Plattform erfolgt in einem voreingestellten Sendeintervall. Die Sendeintervalle sowie die Alarmgrenzen lassen sich über die IIoT-Plattform konfigurieren. Zudem kann der Gerätestatus (aktueller Messwert, Batterielebensdauer etc.) auch vor Ort über ein mobiles Endgerät, durch eine lokale Schnittstelle via Bluetooth[®] Low Energy abgefragt und eingestellt werden.

4.4 Funktionsprinzip

Die Funkeinheit nutzt den Funkstandard Bluetooth[®] Low Energy 4.2 für einen energiesparenden Betrieb. Im Connected Mode kann die Funkeinheit vor Ort über ein mobiles Endgerät mit der APP „myWIKA wireless device“ konfiguriert werden.

Der zuletzt aufgenommene Messwert wird über Bluetooth[®] Low Energy im „Advertising Mode“ mit einem Interval von 1,25 s übertragen. Die Messwertdaten können aus dem Advertising optional entfernt werden.

→ Für Details zur Bluetooth[®]-Verbindung, siehe Kapitel 2.8 „Datenübertragungssicherheit“ und die Zusatzdokumentation „Special documentation for BLE communication protocol, model TRW“ auf der WIKA-Webseite

Typische Anwendungen

- Signalaufnahme
- Setzen der Alarmparameter
- Fehlerdiagnose
- Konfigurations-ID (zur Identifikation von Änderungen der Senderate)
- Konfigurationsänderung (z. B. Senderate, Alarmparameter etc.)



Einstellung des zu messenden Analogsignals bzw. RTD-Signals kann nur über Bluetooth[®] erfolgen.

5. Inbetriebnahme und Betrieb

Personal: Fachpersonal



WARNUNG!

Körperverletzung

Bei der Inbetriebnahme besteht Gefahr durch aggressive Messstoffe und hohe Drücke.

- ▶ Angaben im Sicherheitsdatenblatt für den entsprechenden Messstoff beachten.
- ▶ Vor Anschluss an einen Behälter, eine Rohrleitung oder ein System, diese drucklos schalten.



WARNUNG!

Körperverletzungen, Sach- und Umweltschäden durch gefährliche Messstoffe

Bei Kontakt mit gefährlichen Messstoffen (z. B. Sauerstoff, Acetylen, brennbaren oder giftigen Stoffen), gesundheitsgefährdenden Messstoffen (z. B. ätzend, giftig, krebserregend, radioaktiv) sowie bei Kälteanlagen, Kompressoren besteht die Gefahr von Körperverletzungen, Sach- und Umweltschäden. Im Fehlerfall können am Gerät gefährliche Messstoffe mit extremer Temperatur (über 55 °C [131 °F]) anliegen.

- ▶ Bei diesen Messstoffen müssen über die gesamten allgemeinen Regeln hinaus die einschlägigen Vorschriften beachtet werden.
- ▶ Notwendige Schutzausrüstung tragen.



WARNUNG!

Körperverletzungen, Sach- und Umweltschäden durch gefährliche Messstoffe

Bei Kontakt mit gefährlichen Messstoffen (z. B. Sauerstoff, Acetylen, brennbaren oder giftigen Stoffen), gesundheitsgefährdenden Messstoffen (z. B. ätzend, giftig, krebserregend, radioaktiv) sowie bei Kälteanlagen, Kompressoren besteht die Gefahr von Körperverletzungen, Sach- und Umweltschäden. Im Fehlerfall können am Gerät gefährliche Messstoffe unter hohem Druck oder Vakuum anliegen.

- ▶ Bei diesen Messstoffen müssen über die gesamten allgemeinen Regeln hinaus die einschlägigen Vorschriften beachtet werden.
- ▶ Notwendige Schutzausrüstung tragen.



WARNUNG!

Körperverletzungen, Sach- und Umweltschäden durch unter hohem Druck austretende Messstoffe

Bei der Druckbeaufschlagung des Geräts kann aufgrund schlechter Abdichtung des Prozessanschlusses Messstoff unter hohem Druck entweichen. Durch die hohe Energie des im Fehlerfall austretenden Messstoffs besteht die Gefahr von Körperverletzungen und Sachschäden.

- ▶ Die Abdichtung des Prozessanschlusses muss fachgerecht ausgeführt und auf Dichtheit überprüft werden.



VORSICHT!

Sachschaden durch elektrostatische Entladung (ESD)

Bei Arbeiten mit offenen Schaltkreisen (Leiterplatten) besteht die Gefahr empfindliche elektronische Bauteile durch elektrostatische Entladung zu beschädigen.

- ▶ Die ordnungsgemäße Verwendung geerdeter Arbeitsflächen und persönlicher Armbänder ist erforderlich.
- ▶ Bei geöffnetem Batteriefach, z. B. beim Wechsel der Batterie, ist auf einen ausreichenden ESD-Schutz zu achten.
- ▶ Leiterplatten und elektrische Bauteile nicht berühren.
- ▶ Vor dem Abnehmen des Kunststoffdeckels den geerdeten metallischen Gehäuseteil bzw. einen benachbarten geerdeten metallischen Gegenstand (z. B. Heizkörper, Rohrleitungen) berühren (statische Ladungen werden vom Körper abgeleitet).
- ▶ Den Kontakt zwischen Elektronik und Kleidungsstücken vermeiden.

Nur Originalteile verwenden, siehe Kapitel 10 „Zubehör und Ersatzteile“.

Gerät auf eventuell vorhandene Schäden untersuchen.

Bei Schäden Gerät nicht in Betrieb nehmen und unverzüglich Kontakt mit dem Hersteller aufnehmen.



Information

Mechanische Belastungen der elektrischen Anschlüsse und der Gehäuse vermeiden. Alle Anschlüsse nur im drucklosen und abgekühlten Zustand öffnen.

Maximal zulässige Temperaturen

- Am Gehäuse: 70 °C [158 °F]
- Am Prozessanschluss (Ausführung mit FKM O-Ring):
-20 ... +125 °C [-4 ... +257 °F]

5. Inbetriebnahme und Betrieb

DE

5.1 Mechanische Montage

Wird das Widerstandsthermometer direkt in den Prozess eingeschraubt, können sich Einbaulänge sowie Strömungsgeschwindigkeit und Viskosität des Prozessmediums reduzierend auf die maximale Fühlerbelastung auswirken.

Das Gehäuse muss gegen elektromagnetische Felder und elektrostatische Aufladungen geerdet werden. Es muss nicht gesondert an das Potenzialausgleichssystem angeschlossen werden, wenn es festen und gesicherten metallischen Kontakt mit dem Behälter oder dessen Konstruktionsteilen oder Rohrleitungen hat, sofern diese mit dem Potenzialausgleichssystem verbunden sind.

Bei einem nichtmetallischen Kontakt mit dem Behälter oder dessen Konstruktionsteilen bzw. Rohrleitungen müssen alle in den explosionsgefährdeten Bereich ragende, elektrisch leitende Thermometerkomponenten mit einem Potenzialausgleichssystem verbunden sein.

Anzugsdrehmomente für Klemmverschraubungen

Dichtung	Umdrehungen	Max. Druck in bar [psi]
Klemmring CrNi-Stahl	1 ¼ ... 1 ½	100 [1.450]
Schneidring CrNi-Stahl	1 ¼ ... 1 ½	100 [1.450]
Klemmring PTFE	1 ¼ ... 1 ½	8 [116]

5.2 Erste Konfiguration

Die Funkeinheit auf eventuell vorhandene Schäden untersuchen. Offensichtliche Schäden unverzüglich mitteilen.



Die Funkeinheit zuerst ohne angeschlossenem Messgerät in Betrieb nehmen. Die Konfiguration mit dem passenden WIKA-Sensor muss im Vorfeld erfolgen, um Schäden am Messgerät oder der Funkeinheit zu vermeiden.

5. Inbetriebnahme und Betrieb

5.3 Herstellen der Energieversorgung

Die Energieversorgung wird über die interne Batterie hergestellt.

Batterie anschließen

Im Lieferzustand ist die Batterie nicht mit der Elektronik verbunden.

Anschluss der Batterie, siehe Kapitel 7.2 „Batteriehandhabung“:

1. Das Gehäuse öffnen: Je nach Ausführung der Funkeinheit ist ein Bajonettverschluss (Kunststoff-Ausführung) oder Schraubverschluss (Metall-Ausführung) verbaut. Dazu die Geräteober- und unterseite mit den Händen greifen und entsprechend der Kennzeichnung auf dem Deckel verdrehen.
2. Batterie-Stecker einstecken und einrasten (⇒ LED leuchtet).
3. Gehäuse aufsetzen und verschließen. Dazu Geräteober- und unterseite mit den Händen greifen und entsprechend der Kennzeichnung auf dem Deckel entgegengesetzt verdrehen.

5.4 Verbinden der Funkeinheit mit einem Messgerät

Für die ersten 25 Minuten nach Anschluss der Energieversorgung ist die LED-Funktion aktiviert.

LED-Farbe	Modus	Bedeutung
Blau	Blinkt einmal	Interne Kommunikation zwischen Funkplatine und Sensorplatine
Cyan	AN für die Dauer des Join-Prozesses	LoRaWAN® Join-Prozess läuft
Cyan	Blinkt einmal	LoRaWAN® Join-Prozess erfolgreich
Rot	Blinkt zweimal	LoRaWAN® Join-Prozess nicht erfolgreich
Rot	Blinkt zweimal	LoRaWAN® Datenübertragung nicht erfolgreich (Confirmed Message)
Grün	Blinkt zweimal	LoRaWAN® Datenübertragung erfolgreich (Confirmed Message)

Hinweise zur Sendecharakteristik

- Um eine bestmögliche Sendequalität zu erreichen, sollte die Funkstrecke vom Endgerät bis zum Empfangsgateway möglichst frei von Barrieren sein.
- Die Signalstärke wird durch Betonwände, metallische Abschirmung, Einhausungen sowie durch hügelige Landschaften leicht bis stark beeinträchtigt.
- Für eine bestmögliche Sendeleistung der Antenne dürfen sich keine metallischen Gegenstände, wie z. B. Rohrleitungen, näher als 10 cm [3,94 in] an der Antenne befinden.
- Bei der Installation die Sendecharakteristik des Geräts sowie die Hinweise aus der folgenden Abbildung beachten:

Abstrahlcharakteristik:

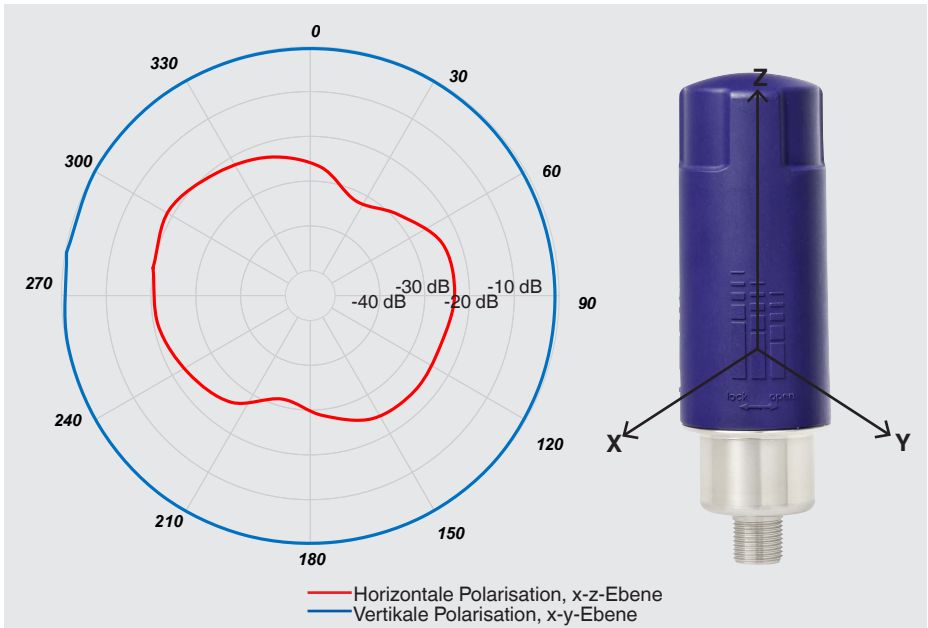

Hinweise zum Anbringen des Empfangsgateways

Das Gateway so positionieren, dass die Sendeleistung des Geräts optimal ausgenutzt wird. Dabei sollten folgende Empfehlungen beachtet werden:

- Je nach Verwendung sollte ein Gateway für den Innen- oder Außeneinsatz gewählt werden.
- Die Abstrahlcharakteristik der Antenne sollte bei der Gatewaypositionierung berücksichtigt werden.
- Befinden sich die Sensoren in einer Ebene ist eine vertikale Montage der LoRaWAN® Antenne am Gateway zu empfehlen. Der Standort sollte idealerweise mittig in der abzudeckenden Fläche sein.
- Befinden sich die Sensoren auf mehreren Ebenen sollte das Gateway mittig im Gebäude platziert werden und die Gateway-Antenne horizontal ausgerichtet werden.
- Eine weitere Möglichkeit ist es, das Gateway außerhalb des Gebäudes zu platzieren und die Antenne vertikal auszurichten. So kann von außen in mehrere Stockwerke eine ausreichende Funkverbindung hergestellt werden.
- Im Außenbereich ist darauf zu achten, dass das Gateway in ausreichender Höhe angebracht wird und in nächster Nähe von nichts verdeckt wird. Je höher das Gateway positioniert wird, desto weiter reicht die LoRaWAN® Verbindung.

5. Inbetriebnahme und Betrieb

5.5 App „myWIKa wireless device“



Über die App „myWIKa wireless device“ und eine Bluetooth® Low Energy Verbindung lässt sich die Funktionalität der LoRaWAN® Kommunikation per mobilem Endgerät aktivieren bzw. deaktivieren. Darüber hinaus lassen sich via App die Gerätedaten sowie der aktuelle Messwert auslesen. Dazu den Anweisungen auf dem Bildschirm folgen.

DE

5.6 Batteriestatus

Die Batterielebensdauer wird von Faktoren wie der Senderate, dem Spreizfaktor oder den Umgebungstemperaturen beeinflusst. Beim Berechnen des Werts wird von einer konstanten Umgebungstemperatur von 20 °C [68 °F] ausgegangen. Die Batterielebensdauer wird als prozentualer Wert über Bluetooth® im Advertising Frame und über LoRaWAN® übertragen.

Bei Werten unterhalb von 20 % der erwarteten Rest-Lebensdauer wird ein Batteriewechsel empfohlen. Bei völliger Entladung der Batterie werden keine Werte mehr über die Funkeinheit übertragen.

5.7 Anbindung der Funkeinheit in ein LPWAN

Die Funkeinheit kann über LoRaWAN® an eine IIoT-Infrastruktur angebunden werden. Hierfür wird die Funkeinheit mit einem LoRaWAN®-Gateway verbunden und die Messwerte in frei konfigurierbaren Zeitabständen in die IIoT-Infrastruktur (z. B. Cloud-Plattform, PC, mobiles Endgerät etc.) übertragen.

Für die IIoT-Anbindung werden alle relevanten Daten zur Registrierung und Inbetriebnahme, sowie eine Schnittstellenspezifikation für die Weiterverarbeitung der Daten zur Verfügung gestellt, siehe die Zusatzdokumentation „Special documentation for LoRaWAN® communication protocol, TRW“, 14617652.

Das Bereitstellungspaket beinhaltet folgende Registrierungsdaten:

- DevEUI (64-bit end-device, unique identifier)
- AppEUI (64-bit unique, application identifier)
- AppKey (128-bit Schlüssel)



Bei einer kundenspezifischen Anbindung muss die Payload-Integration entsprechend der Zusatzdokumentation „Special documentation for LoRaWAN® communication protocol, model TRW“ auf der WIKa-Webseite kundenseitig erfolgen.

5.8 Alarmbeschreibung

Drei grundsätzliche Alarmarten können konfiguriert werden: Alarmgrenze, Alarmgrenze mit Verzögerung, Messsignaländerung.

Diese Alarme können mit Hilfe der App „myWIKA wireless device“ über Bluetooth® oder per LoRaWAN®-Anbindung über die WIKA-Cloud eingestellt werden.

Für eine kundeneigene Anbindung ohne WIKA-App oder WIKA-Cloud ist die „Special documentation for LoRaWAN® communication protocol, model TRW“ zu beachten.

DE

Eine Kombination der Alarmfunktionen ist möglich, z. B. Alarmgrenze steigender und fallender Messwert, um ein Betriebsfenster der Anwendung festzulegen.

Alarmgrenze, steigender Messwert

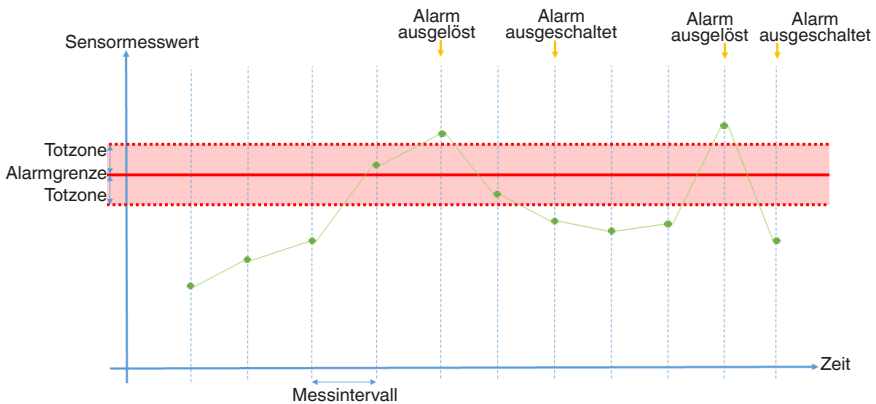

5. Inbetriebnahme und Betrieb

Alarmgrenze, fallender Messwert

DE

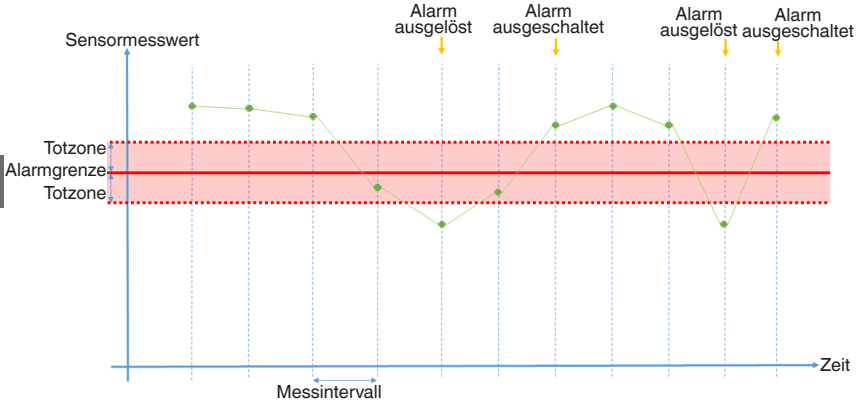

Alarmgrenze, steigender Messwert mit Verzögerung

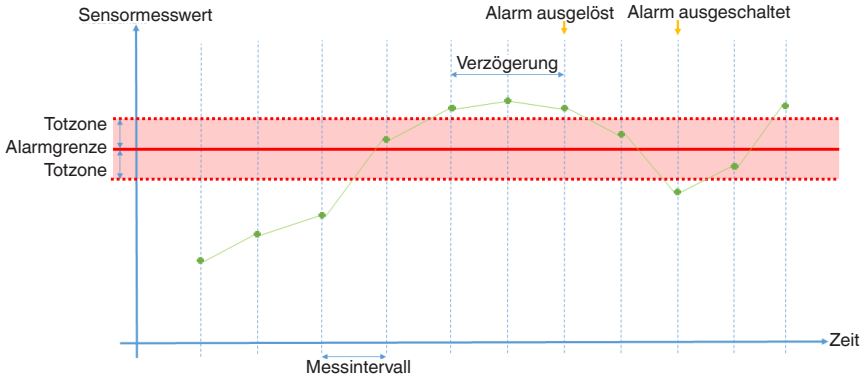

Alarmgrenze, fallender Messwert mit Verzögerung

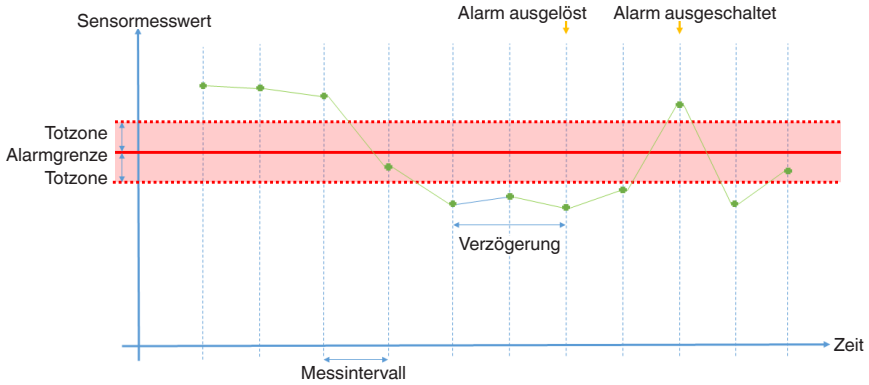

→ Zur Außerbetriebnahme und wenn beabsichtigt, die Anlage längere Zeit außer Betrieb zu setzen, siehe Kapitel 8.1 „Demontage“.

Messwertänderung (slope) fallend

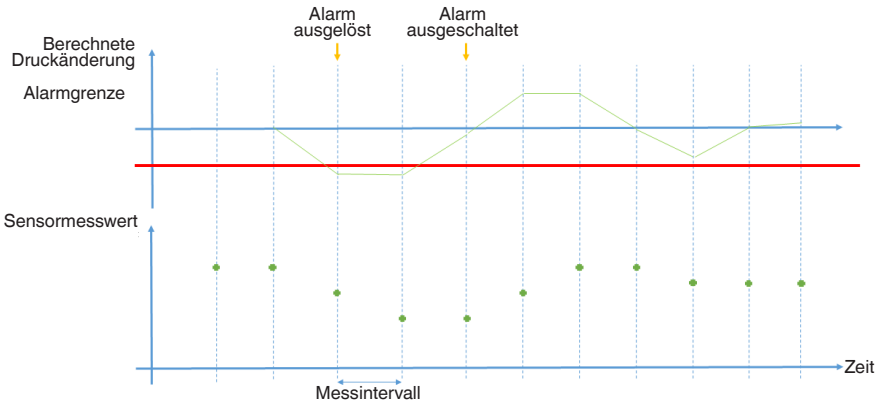

Ein Wärmeeintrag (z.B. Wärmefluss vom Prozess oder Strahlungswärme aus der Umgebung), der die zulässige Umgebungstemperatur des Gehäuses überschreitet ist nicht zulässig und muss verhindert werden. Z.B. durch geeignete thermische Entkopplung oder ein ausreichend langes Halsrohr oder geeignete Vor-Ort-Maßnahmen. Der Wärmeeintrag muss vom Anwender durch Rechnung oder Messung bestimmt werden.

6. Störungen

Personal: Fachpersonal



VORSICHT!

Körperverletzungen, Sach- und Umweltschäden

Können Störungen mit Hilfe der aufgeführten Maßnahmen nicht beseitigt werden, Gerät unverzüglich außer Betrieb setzen.

- ▶ Sicherstellen, dass kein Signal mehr übertragen wird und gegen versehentliche Inbetriebnahme schützen.
- ▶ Kontakt mit dem Hersteller aufnehmen.
- ▶ Bei notwendiger Rücksendung die Hinweise unter Kapitel 8 „Demontage, Rücksendung und Entsorgung“.

DE



Kontaktdaten siehe Kapitel 1 „Allgemeines“ oder Rückseite der Betriebsanleitung.

Störung	Ursachen	Maßnahmen
Anbindung an die IIoT-Plattform ist nicht erfolgreich	Zugangsdaten verloren	Kundendienst kontaktieren
	Falsche Zugangsdaten	Überprüfung anhand der mitgelieferten Zugangsdaten
	Kundenseitige Firewall blockiert Schnittstellen	Infrastruktur-Verantwortlichen kontaktieren
	Gerät befindet sich außerhalb der Reichweite des Gateways	Hinweise gemäß Betriebsanleitung beachten.
	Fehlerhafte Inbetriebnahme oder unzulässige, ungeeignete Einbaustelle	Hinweise gemäß Betriebsanleitung beachten
QR-Code ist nicht auslesbar	Ungünstige Licht- und Abstandsverhältnisse	Optimierung durch Nutzer

6. Störungen

DE

Störung	Ursachen	Maßnahmen
Keine Messwertübertragung nach voriger uneingeschränkter Funktion	Batterie leer	Batterie wechseln, siehe Kapitel 7.2 „Batteriehandhabung“
	Fehlerhafter Batteriewechsel	Überprüfung des Batteriewechsels bzw. Ladezustand der Batterie
	Gerät außerhalb der Reichweite des Gateways	Hinweise gemäß Betriebsanleitung beachten, siehe Kapitel „Hinweise zum Anbringen des Empfangsgateways“
	Beschädigung durch nicht bestimmungsgemäße Verwendung	Bestimmungsgemäße Verwendung beachten, siehe Kapitel 2.1 „Bestimmungsgemäße Verwendung“
	Änderungen in der Infrastruktur	Infrastruktur-Verantwortlichen kontaktieren
Keine Verbindung zum Gateway	Gateway ist ausgeschaltet	Gateway einschalten und sicherstellen, dass eine Verbindung zum Netzwerkservers besteht
Einzelner Messwert nicht übertragen	Kollision bei der Datenübertragung	Nicht vermeidbar! Anpassung der Infrastruktur möglich
Bluetooth®-Übertragung funktioniert nicht	Batterie noch nicht angeschlossen	Gehäuse abnehmen und Batterie anschließen, siehe Kapitel 7.2 „Batteriehandhabung“
	Batterie leer	Gehäuse abnehmen und Batterie wechseln, siehe Kapitel 7.2 „Batteriehandhabung“
	Gerät außer Reichweite	Abstand zum Gerät verringern
	Bluetooth® des mobilen Endgeräts nicht aktiviert	Bluetooth®-Funktion des mobilen Endgeräts aktivieren
Mechanische Beschädigungen	Unsachgemäße Handhabung	Gerät austauschen
	Unzulässige Belastung an der Einbaustelle (z. B. Brand).	
Koppelung über Bluetooth® funktioniert nicht	Unsachgemäße Handhabung (5x falsche Eingabe des Keys)	Batterie Reset tätigen und mit korrektem BLE Key anmelden
		Hersteller kontaktieren

7. Wartung

Personal: Fachpersonal



Kontaktdaten siehe Kapitel 1 „Allgemeines“ oder Rückseite der Betriebsanleitung.

DE

7.1 Wartung

Reparaturen sind ausschließlich vom Hersteller durchzuführen.

Ausgenommen ist der Austausch der Batterien, Sicherungen und Dichtungen.

Nur Originalteile verwenden, siehe Kapitel 10 „Zubehör und Ersatzteile“.

7.2 Batteriehandhabung

Für den Batteriewechsel folgende Hinweise beachten:

- Batteriewechsel nur in einer trockenen Umgebung durchführen.
- Keine Akkus verwenden.
- Nur freigegebene Batterietypen verwenden, siehe Kapitel 7.2 „Batteriehandhabung“.
- Kein elektrisches Werkzeug zum Verschrauben verwenden.



Bei längerer Inaktivität des Geräts die Batterie entnehmen.

Nach Batteriewechsel muss der Befehl „Batterie getauscht“ in der App „myWIKA wireless device“ unter Aktionen oder alternativ via Cloud gesendet werden.



Nach dem Ausführen des Befehls „Batterie getauscht“ darf die Batterie für mindestens 24 Stunden nicht vom Sensor getrennt werden.

7. Wartung

Batterie entnehmen:



DE

Vorgehensweise

1. Das Gehäuseoberteil öffnen. Die Geräteober- und unterseite mit den Händen greifen und entgegengesetzt verdrehen.
2. Gehäuseoberteil nach oben abnehmen.
3. Den Batterie-Stecker abziehen.
4. Die Batterie entnehmen.

Batterie einsetzen:



Vorgehensweise

1. Die neue Batterie in die Vorrichtung einsetzen.
 2. Den Stecker an der Leiterplatte anschließen.
 3. Zum Verschließen des Sensors das Gehäuseoberteil aufsetzen. Die Geräteober- und unterseite mit den Händen greifen und entgegengesetzt fest verdrehen.
- Beim Schließen des Gehäuseoberteils sicherstellen, dass die Batterieanschlusskabel nicht eingeklemmt sind.

7.3 Reinigung



VORSICHT!

Körperverletzungen, Sach- und Umweltschäden

Messstoffreste können zur Gefährdung von Personen, Umwelt und Einrichtung führen.

- ▶ Reinigungsvorgang nach Herstellervorgaben durchführen.

DE



VORSICHT!

Sachschaden durch unsachgemäße Reinigung

Eine unsachgemäße Reinigung führt zur Beschädigung des Geräts.

- ▶ Keine aggressiven Reinigungsmittel verwenden.
- ▶ Keine harten und spitzen Gegenstände zur Reinigung verwenden.
- ▶ Keine scheuernden Tücher oder Schwämme verwenden.

1. Vor der Reinigung das Gerät ordnungsgemäß von der Stromversorgung trennen und bei Bedarf die Datenübertragung während der Reinigung deaktivieren.
2. Das Gerät mit einem feuchten Tuch reinigen.

8. Demontage, Rücksendung und Entsorgung

Personal: Fachpersonal

8.1 Demontage



WARNUNG!

Körperverletzungen, Sach- und Umweltschäden durch Messstoffreste

Bei Kontakt mit gefährlichen Messstoffen (z. B. Sauerstoff, Acetylen, brennbaren oder giftigen Stoffen), gesundheitsgefährdenden Messstoffen (z. B. ätzend, giftig, krebserregend, radioaktiv) sowie bei Kälteanlagen, Kompressoren besteht die Gefahr von Körperverletzungen, Sach- und Umweltschäden.

- ▶ Vor der Einlagerung das ausgebaute Gerät (nach Betrieb) spülen bzw. säubern.
- ▶ Angaben im Sicherheitsdatenblatt für den entsprechenden Messstoff beachten.



GEFAHR!

Verbrennungsgefahr

Bei Berührung besteht Verbrennungsgefahr durch heiße Oberflächen.

- ▶ Vor dem Ausbau das Gerät ausreichend abkühlen lassen!



WARNUNG!

Körperverletzung

Bei der Demontage besteht Gefahr durch aggressive Messstoffe und hohe Drücke.

- ▶ Angaben im Sicherheitsdatenblatt für den entsprechenden Messstoff beachten.
- ▶ Widerstandsthermometer nur im drucklosen Zustand demontieren.

1. Gerät mit Schraubenschlüssel über die Schlüssel­fläche lösen.
2. Gerät mit der Hand herausschrauben.



Bei getrennter Steckverbindung den elektrischen Anschluss nicht mit Feuchte in Berührung bringen!

8. Demontage, Rücksendung und Entsorgung

Zur Außerbetriebnahme und Stilllegung Folgendes beachten:

- Persönliche Kennwörter zurücksetzen.
- Maschine/Anlage ordnungsgemäß abschalten.
- Batterie entnehmen bzw. Spannungsversorgung abtrennen.

8.2 Rücksendung

DE

Beim Versand des Geräts unbedingt beachten:

- Alle an WIKA gelieferten Geräte müssen frei von Gefahrstoffen (Säuren, Laugen, Lösungen, etc.) sein und sind daher vor der Rücksendung zu reinigen, siehe Kapitel 7.3 „Reinigung“.
- Zur Rücksendung des Geräts die Originalverpackung oder eine geeignete Transportverpackung verwenden.

Um Schäden zu vermeiden:

1. Das Gerät in eine antistatische Plastikfolie einhüllen. (bei Geräten mit elektrischen Bauteilen).
2. Das Gerät in der Verpackung platzieren und gleichmäßig dämmen.
3. Wenn möglich einen Beutel mit Trocknungsmittel der Verpackung beifügen.
4. Sendung als Transport eines hochempfindlichen Messgeräts kennzeichnen.



Hinweise zur Rücksendung befinden sich in der Rubrik „Service“ auf unserer lokalen Internetseite (Rücksendungs-Applikation). Vor der Rücksendung ist die Datenübertragung der Funkeinheit zu deaktivieren.

8.3 Entsorgung

Durch falsche Entsorgung können Gefahren für die Umwelt entstehen. Gerätekomponenten und Verpackungsmaterialien entsprechend den landesspezifischen Abfallbehandlungs- und Entsorgungsvorschriften umweltgerecht entsorgen.



Nicht mit dem Hausmüll entsorgen. Für eine geordnete Entsorgung nach nationalen Vorgaben sorgen.

Entsorgung der Batterien



WARNUNG!

Umwelt- und Gesundheitsschäden durch falsche Entsorgung von Batterien und Akkus

Batterien und Akkus enthalten Schadstoffe wie Schwermetalle, die bei unsachgemäßer Entsorgung der Umwelt und der Gesundheit Schaden zufügen.

- ▶ Batterien und Akkus nicht mit dem Hausmüll entsorgen.
- ▶ Für eine geordnete Entsorgung nach nationalen Vorgaben sorgen.
- ▶ Die aktuell geltenden Vorschriften dabei beachten.
- ▶ Gebrauchte Batterien und Akkus zur umweltgerechten Entsorgung beim Handel oder entsprechenden Sammelstellen nach nationalen oder lokalen Bestimmungen abgeben.

DE

Die getrennte Sammlung und Verwertung von Batterien leistet einen wichtigen Beitrag zur Entlastung der Umwelt und Vermeidung von Gefahren für die Gesundheit.



Batterien enthalten wertvolle Rohstoffe wie Eisen, Zink, Mangan oder Nickel, die wiedergewonnen werden können.

9. Technische Daten

9. Technische Daten

Genauigkeitsangaben

Gesamtgenauigkeit	<ul style="list-style-type: none">■ ≤ 300 °C: +/- 1,4 °K■ > 300 °C: +/- 2,9 °K
--------------------------	--

Referenzbedingungen	Nach IEC 62828-1
----------------------------	------------------

DE

Messbereich

Temperaturbereich ¹⁾	<ul style="list-style-type: none">■ -196 ... +300 °C [-321 ... +572 °F]■ -50 ... +300 °C [-58 ... +572 °F]■ -50 ... +500 °C [-58 ... +932 °F] <p>Ausführung mit FKM O-Ring -20 ... +125 °C [-4 ... +257 °F]</p>
--	---

1) Den Temperaturtransmitter dabei vor Temperaturen unter -20 °C [-4 °F] und über +60 °C [+140 °F] schützen.

Prozessanschluss

Art des Prozessanschlusses	<ul style="list-style-type: none">■ G ¼ B■ G ⅜ B■ G ½ B■ ¼ NPT■ ½ NPT■ M12 x 1,5■ M20 x 1,5■ 7/16-20 UNF-2A■ Klemmverschraubung G ¼ B (Metallklemmring)■ Klemmverschraubung G ⅜ B (Metallklemmring)■ Klemmverschraubung G ½ B (Metallklemmring)■ Klemmverschraubung ¼ NPT (Metallklemmring)■ Klemmverschraubung ½ NPT (Metallklemmring)■ Klemmverschraubung G ¼ B (PTFE-Klemmring)■ Klemmverschraubung G ⅜ B (PTFE-Klemmring)■ Klemmverschraubung G ½ B (PTFE-Klemmring)■ Klemmverschraubung ¼ NPT (PTFE-Klemmring)■ Klemmverschraubung ½ NPT (PTFE-Klemmring)■ Überwurfmutter G ⅜, Sensor gefedert (zum Einbau in ein Schutzrohr)■ M24 x 1,5 Innengewinde, Sensor gefedert (zum Einbau in ein Schutzrohr/Halsrohr)■ Spannband (zur Befestigung auf Oberflächen)
-----------------------------------	--

Sensor

Sensordurchmesser	<ul style="list-style-type: none">■ 3 mm [0,12 in]■ 6 mm [0,24 in]
--------------------------	---

14642235.02.02/2024 EN/DE

9. Technische Daten

DE

Prozessanschluss

Einbaulänge ¹⁾

- 50 mm [1,97 in]
 - 75 mm [2,95 in]
 - 100 mm [3,94 in]
 - 120 mm [4,72 in]
 - 150 mm [5,91 in]
 - 200 mm [7,87 in]
 - 250 mm [9,84 in]
 - 300 mm [11,81 in]
 - 350 mm [13,78 in]
 - 400 mm [15,75 in]
- → Weitere Einbaulängen auf Anfrage

Schutzrohr

Anschluss zum Thermometer

- Überwurfmutter G 3/8, Sensor gefedert
- M24 x 1,5 Innengewinde, Sensor gefedert

- 1) Die Fühlerspitze darf auf einer Länge von 60 mm [2,59 in] nicht gebogen werden. Am Übergang zum Transmitter darf im Abstand von 30 mm [1,18 in] zum Gehäuse gebogen werden. Das Mantel-Widerstandsthermometer darf mit dem Radius 5-facher Durchmesser gebogen werden.
- 2) Verschiedene Schutzrohre für den Einsatz in der sterilen Verfahrenstechnik sind mit dem TRW kombinierbar.

Schutzrohrbeispiele für die sterile Verfahrenstechnik

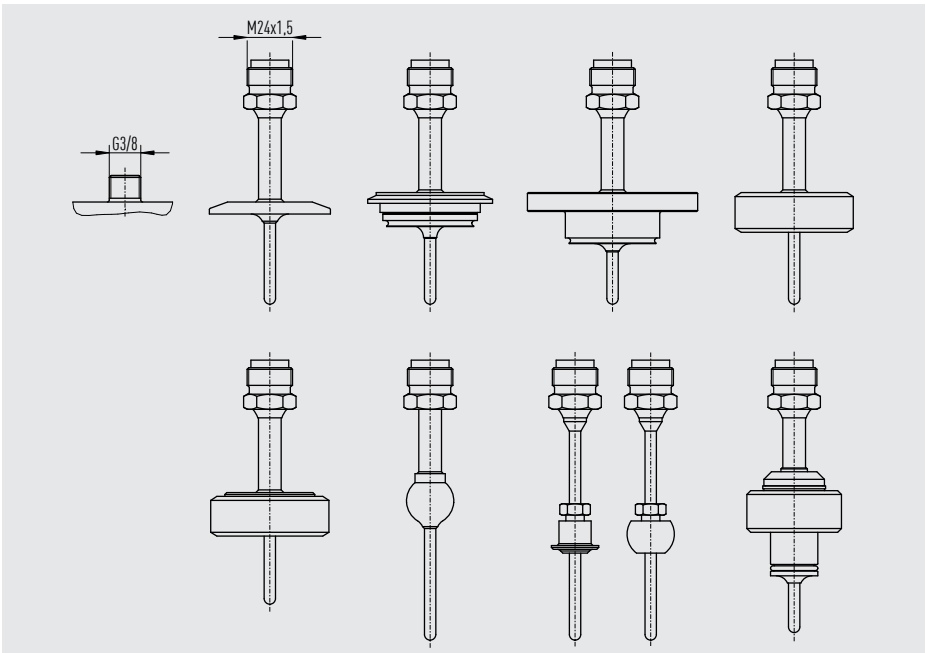

→ Details siehe Datenblatt TW 95.22

14642235.02.02/2024 EN/DE

9. Technische Daten

DE

Funkstandard		
LoRaWAN®		
Spezifikation	LoRaWAN® 868 MHz EU	
Protokollversion	1.0.3	
Funktionen des Protokolls	<ul style="list-style-type: none"> ■ Anmeldung ■ Konfiguration ■ Senden von Messwerten ■ Alarmverwaltung ■ Batteriestatus 	
Frequenzbereich	863 ... 870 MHz	
Reichweite im Freifeld	Typisch 10 km [6 mi] → Abhängig von den Umgebungsbedingungen wie Topographie und Gebäudestrukturen.	
Antenne	PCB-Antenne, intern	
Kanalabstand	200 kHz	
Bandbreite	125 kHz	
Max. Sendeleistung	14 dBm	
Sendeintervall	Standard	30 Minuten
	Minimum	1 Minute (maximale Übertragungsrate begrenzt nach ETSI EN 300 220) → Beschränkung des Sendintervalls nach ETSI EN 300 220 möglich. Die maximale Sendefrequenz und das Tastverhältnis (Duty Cycle) entsprechen der Norm ETSI EN300 220.
	Maximum	7 Tage
Sicherheit	Vollständige Ende-zu-Ende Verschlüsselung nach AES-128 → Für Details zur Sicherheit siehe Webseite: https://loralliance.org	
Bluetooth®		
Version	Bluetooth® mindestens 5.0	
	Kompatibel mit allen Bluetooth® Low Energy Versionen min. 4.2	
Funktionen	<ul style="list-style-type: none"> ■ Anmeldung ■ Konfiguration ■ Senden von Messwerten ■ Alarmverwaltung ■ Batteriestatus ■ Datenlogger 	

14642235.02.02/2024 EN/DE

9. Technische Daten

DE

Funkstandard	
Frequenzbereich	2,4 GHz
Reichweite im Freifeld	Typisch 10 m [32,8 ft], Freifeld → Abhängig von den Umgebungsbedingungen wie Topographie und Gebäudestrukturen.
Max. Sendeleistung	4 dBm
Antenne	Chip-Antennen intern
Sendeintervall	1,25 Sekunden
	→ Ein Update des Messwerts erfolgt nur im eingestellten Messintervall.

→ Weitere ausführliche Informationen zu den Funkprotokollen siehe www.wika.de

Spannungsversorgung und Leistungsdaten		
Batterie-Pack	Lithium-Thionylchlorid-Batterie (Typ Tadiran SL860/S) und Hybrid Layer Capacitor (Typ Tadiran HLC1020L) als Zusammenbau mit Anschlusskabel konfektioniert, siehe Kapitel 10 „Zubehör und Ersatzteile“	
Batteriespannung	DC 3,6 V	
Batterielebensdauer	> 10 Jahre (Mess- und Sendeintervall 1 Stunde, Spreizfaktor 10) → Bei Referenzbedingungen	
Stromaufnahme	Max. 50 mA	
Messintervall	Standard	1 Minute
	Minimum	10 Sekunden → Kleinere Messintervalle auf Anfrage
	Maximum	7 Tage

Werkstoff	
Werkstoff (messtoffberührt)	
Mantelwerkstoff	<ul style="list-style-type: none"> ■ CrNi-Stahl 1.4571 ■ CrNi-Stahl 316L
Prozessanschluss	<ul style="list-style-type: none"> ■ CrNi-Stahl 1.4571 ■ CrNi-Stahl 316L

14642235.02.02/2024 EN/DE

9. Technische Daten

Einsatzbedingungen

Umgebungstemperaturbereich	-20 ... +60 °C [-4 ... +140 °F] ¹⁾
Lagertemperaturbereich	-40 ... +70 °C [-40 ... +158 °F] Ausführung mit FKM O-Ring -20 °C [-4 °F]
Höhenlage nach EN 61010-1	Max. 2.000 m [6,56 ft] über dem Meeresspiegel
Relative Feuchte	20 ... 90 %, keine Betauung
Maximaler Betriebsdruck ^{2) 3)}	
Bei Sensordurchmesser 3 mm [0,12 in]	140 bar [2.030 psi]
Bei Sensordurchmesser 6 mm [0,24 in]	270 bar [3.916 psi]
Zulässiger Verschmutzungsgrad nach EN 61010-1	2
Schwingungsbeständigkeit nach IEC 60068-2-6	5 g (10 ... 200 Hz) ⁴⁾
Schockfestigkeit nach IEC 60068-2-27	10 g, 11 ms
Freier Fall nach IEC 60068-2-31	Einzelverpackung 1,2 m [3,94 ft]
Schutzart nach IEC/EN 60529	■ IP65 ■ IP67
Gewicht	Ca. 0,05 ... 0,7 kg [0,11 ... 1,54 lbs] - je nach Ausführung

- 1) Ausführung -40 ... +60 °C [-40 ... +140 °F] auf Anfrage
- 2) Abhängig von der Geräteausführung. In Verbindung mit einem zusätzlichen Schutzrohr bestimmt dieses den maximalen Betriebsdruck
- 3) Reduzierter Betriebsdruck bei Verwendung einer Klemmverschraubung: CrNi-Stahl: max. 100 bar [1.450 psi] / PTFE: max. 8 bar [116 psi]
- 4) Abhängig von der Geräteausführung. Angabe gilt für Geräteausführungen ohne Halsrohr und für eine maximale Einbaulänge < 100 mm [3,94 in]. Bei Einbaulänge > 100 mm [3,94 in] Einschränkung auf 3 g max.

Alarme

Alarme	Diverse Alarme einstellbar. → Siehe Betriebsanleitung für Details
---------------	--

9. Technische Daten

Zulassungen

Logo	Beschreibung	Land
	EU-Konformitätserklärung	Europäische Union
	RED - Funkanlagenrichtlinie EN 61326 Emission (Gruppe 1, Klasse B) und Störfestigkeit (industrieller Bereich) Dieses Funkgerät darf ohne Einschränkungen in den Mitgliedsstaaten der EU sowie in den Ländern UK, CH, NO, LI verwendet werden. Eine Verwendung in anderen Ländern ist nicht gestattet.	
	RoHS-Richtlinie	

DE

Zertifikate/Zeugnisse

Zertifikate/Zeugnisse	
Zeugnisse	<ul style="list-style-type: none">■ 2.2-Werkszeugnis nach EN 10204 (z. B. Fertigung nach Stand der Technik, Werkstoffnachweis)■ 3.1-Abnahmeprüfzeugnis nach EN 10204 (z. B. Werkstoffnachweis messstoffberührte metallische Teile)

→ Zulassungen und Zertifikate siehe Webseite

9. Technische Daten

Abmessungen in mm [in]

Legende:

A Einbaulänge
 L_1 Gewindelänge
 N (M_H) Halslänge

∅d Sensordurchmesser
 X Höhe Prozessanschluss
 $\frac{1}{4}$ NPT = 15 mm [0,59 in]
 $\frac{1}{2}$ NPT = 19 mm [0,75 in]

DE

Prozessanschluss mit zylindrischem Gewinde (bzw. ohne Prozessanschluss)

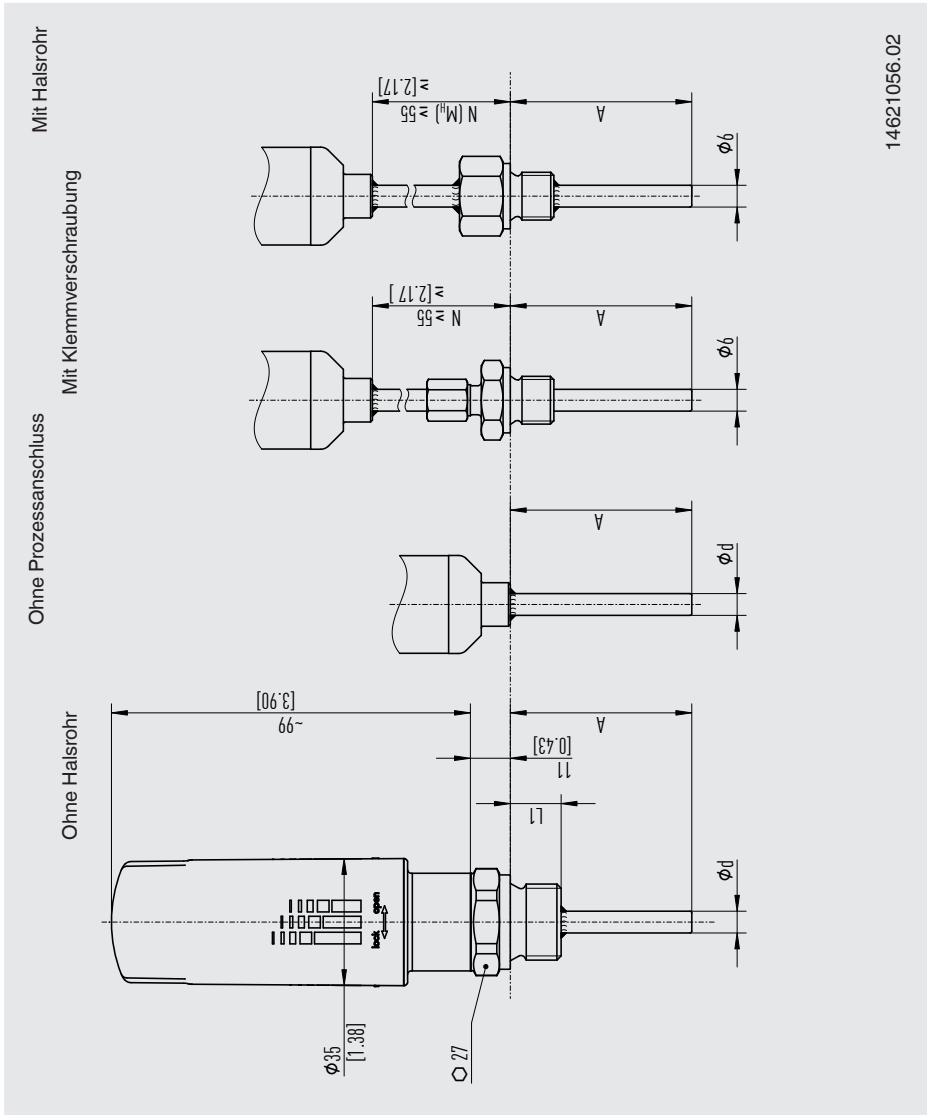

14621056.02

14642235.02 02/2024 EN/DE

9. Technische Daten

Prozessanschluss mit zylindrischem Gewinde (7/16-20 UNF-2A) und O-Ring

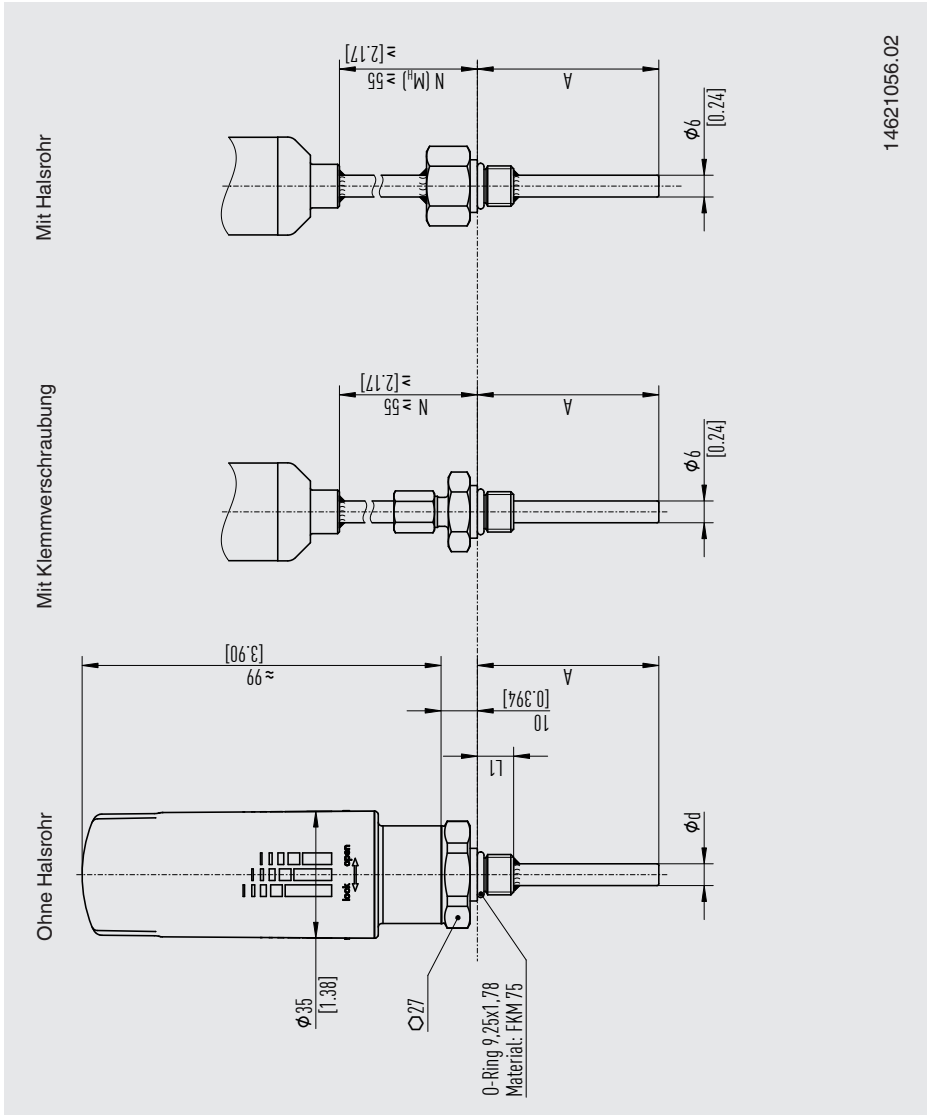

DE

14642235.02 02/2024 EN/DE

Den FKM O-Ring vor Temperaturen kleiner $-20\text{ }^\circ\text{C}$ [$-4\text{ }^\circ\text{F}$] und größer $125\text{ }^\circ\text{C}$ [$257\text{ }^\circ\text{F}$] schützen.

Prozessanschluss mit kegeligem Gewinde

DE

Mit Halsrohr

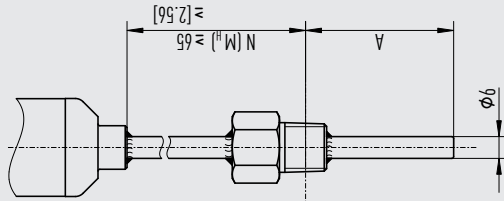

Mit Klemmverschraubung

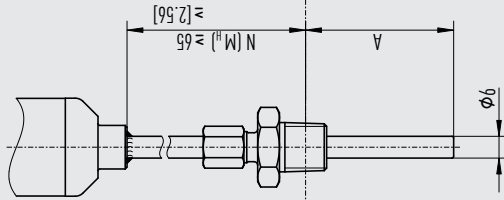

Ohne Halsrohr

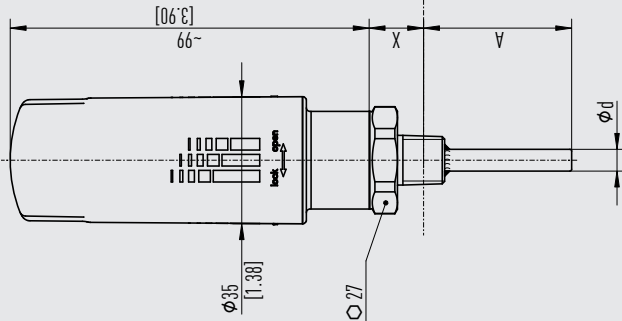

14621056.02

Bei Prozesstemperatur > 150 °C [302 °F] ist eine Halslänge N (MH) von 70 mm [2,76 in] erforderlich, ansonsten N (MH) wählbar (55 mm [2,17 in], 65 mm [2,56 in] oder 70 mm [2,76 in]).

14642235.02/2024 EN/DE

Prozessanschluss zur Oberflächenmessung

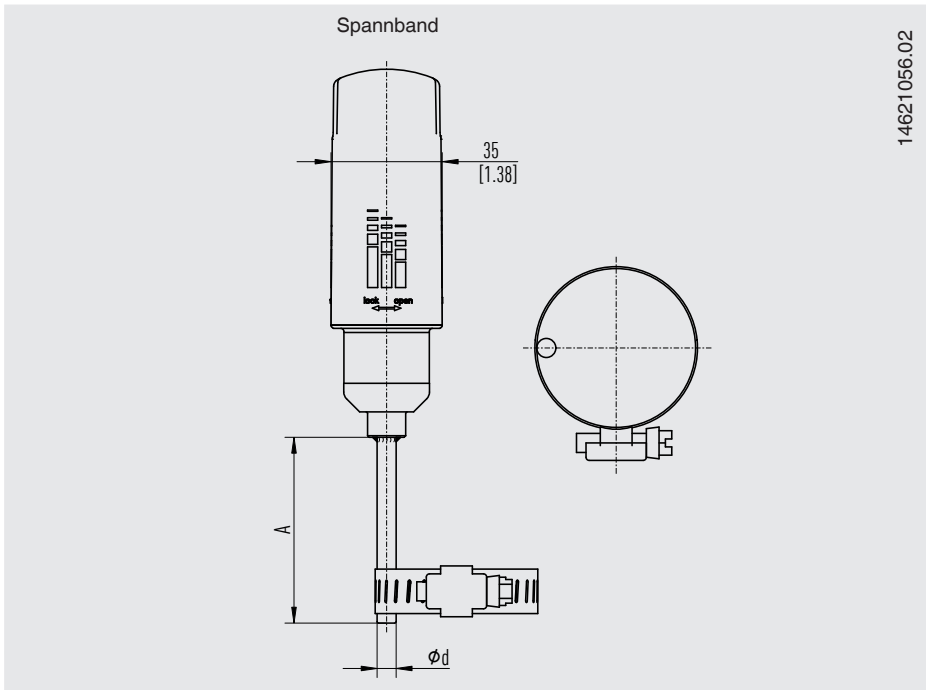

→ Weitere Prozessanschlüsse siehe Datenblatt TW 95.22

Spannbandgröße für Rohrdurchmesser

11 ... 15 mm [0,43 ... 0,59 in]

13 ... 25 mm [0,51 ... 0,98 in]

23 ... 62 mm [0,91 ... 2,44 in]

60 ... 93 mm [2,36 ... 3,66 in]

91 ... 125 mm [3,58 ... 4,92 in]

123 ... 158 mm [4,84 ... 6,22 in]

→ Weitere Größen auf Anfrage: 159 ... 2.500 mm [6,26 ... 98,43 in]

10. Zubehör und Ersatzteile

10. Zubehör und Ersatzteile

Zubehör

Typ	Bestellnummer
LoRaWAN®-Gateway, vorkonfiguriert für WIKA-Netzwerkserver	
Gateway für den Inneneinsatz	Auf Anfrage
Gateway für den Außeneinsatz	Auf Anfrage

DE

Ersatzteile

Typ	Beschreibung	Bestellnummer
Batterie	Lithium-Thionylchlorid-Batterie und Hybrid Layer Capacitor (Typ Tadiran HLC1020L) als Zusammenbau mit Anschlusskabel konfektioniert.	14392747
	Typ Tadiran SL860/S	



EU-Konformitätserklärung EU Declaration of Conformity

Dokument Nr.
Document No. 14657254

Revision
Issue 01

Wir erklären in alleiniger Verantwortung, dass die mit CE gekennzeichneten Produkte
We declare under our sole responsibility that the CE marked products

Typenbezeichnung
Type Designation

TRW-*

Beschreibung
Description

Miniatur-Widerstandsthermometer mit Funkübertragung
Miniature resistance thermometer with wireless transmission

gemäß gültigem Datenblatt
according to the valid data sheet

TE 63.04

mit den nachfolgenden relevanten Harmonisierungsvorschriften
der Union übereinstimmen
*are in conformity with the following relevant Union harmonisation
legislation*

Angewandte harmonisierte Normen oder
sonstige technische Spezifikationen:
*Applied harmonised standards or other
technical specifications:*

2011/65/EU Gefährliche Stoffe (RoHS)
Hazardous substances (RoHS)

EN IEC 63000:2018

2014/53/EU Funkanlagen
Radio Equipment

Gesundheit und Sicherheit (Artikel 3 (1) a))
Protection of health and safety (Article 3 (1) (a))
EN 61010-1:2010 + A1:2019 + A1:2019/AC:2019
EN 62479:2010

Elektromagnetische Verträglichkeit (Artikel 3 (1) b))
Electromagnetic compatibility (Article 3 (1) (b))

EN 301 489-1 V2.2.3
EN 301 489-3 V2.3.0
EN 301 489-17 V3.2.4

EN 61326-1:2013, EN 61326-2-3:2013
stimmt auch überein mit/also complies with
EN IEC 61326-1:2021, EN IEC 61326-2-3:2021

Effektive Nutzung Frequenzspektrum (Artikel 3 (2))
Effective use of spectrum (Article 3 (2))

EN 300 220-1 V3.1.1
EN 300 220-2 V3.2.1
EN 300 228 V2.2.2

Unterszeichnet für und im Namen von / *Signed for and on behalf of*

WIKAL Alexander Wiegand SE & Co. KG

Klingenberg, 2023-11-10

Stefan Heindinger, Vice President
Electrical Temperature Measurement

WIKAL Alexander Wiegand SE & Co. KG
Alexander Wiegand-Strasse 30
63911 Klingenberg
Germany
WEEE-Reg.-Nr. DE 92770372
Rev. 04/2023

Tel. +49 9372 132-0
Fax +49 9372 132-406
E-Mail info@wika.de
www.wika.de

Kommanditgesellschaft: Sitz Klingenberg –
Amtsgericht Aschaffenburg HRA 1819

Komplementärin:
WIKAL International SE – Sitz Klingenberg –
Amtsgericht Aschaffenburg HRB 10505
Vorstand: Alexander Wiegand
Vorsitzender des Aufsichtsrats: Prof. Dr. Roderich C. Thümmel
21AR-04930

Roland Stapf, Head of Quality Management
Process Instrumentation Corporate Quality

14642235.02.02/2024 EN/DE



WIKA subsidiaries worldwide can be found online at www.wika.com.
WIKA-Niederlassungen weltweit finden Sie online unter www.wika.de.



Importer for UK
WIKAI Instruments Ltd
Unit 6 and 7 Goya Business park
The Moor Road
Sevenoaks
Kent
TN14 5GY



WIKAI Alexander Wiegand SE & Co. KG
Alexander-Wiegand-Strasse 30
63911 Klingenberg • Germany
Tel. +49 9372 132-0
info@wika.de
www.wika.de

**Special Documentation for BLE communication protocol,
model TRW**

EN



**Miniature resistance thermometer with wireless transmission,
model TRW**

© 10/2023 WIKA Alexander Wiegand SE & Co. KG
All rights reserved.
WIKA® is a registered trademark in various countries.

Prior to starting work, read the operating instructions!
Keep for later use!

Content

1. General Information	3
1.1 Abbreviations and Definitions	3
1.2 Scope of this Document.....	3
1.3 Conventions.....	4
2. Protocol Description	5
2.1 General architecture	5
2.2 Device compatibility	5
2.3 Bluetooth® password protection.....	5
3. Advertising mode	6
3.1 Device name.....	6
3.2 Sensor data	6
4. Connected mode	8
4.1 GATT general description	8
4.2 Adopted Services	8
4.3 Custom Services.....	8
4.4 Device Commands	19
A. Unit Identifier	20
B. Measurand IDs.....	20

1. General Information

1.1 Abbreviations and Definitions

ATT	Attribute Protocol
BLE	Bluetooth® Low Energy
GAP	Generic Access Profile
GATT	Generic Attribute Profile
LPWAN	Low-power wide-area network
N	Notify
R	Read
SIG	Special Interest Group
TLV-Format	Type, Length, Value Format
UUID	Universal Unique Identifier
W	Write

1.2 Scope of this Document

This document describes the protocol for the Bluetooth® communication with TRW devices. The communication interface can be used together with the dedicated “myWIKa wireless device” mobile application available for Android and iOS. It is also possible to communicate with the device using for example a compatible Bluetooth® gateway together with the information on the following pages.

1. General Information

1.3 Conventions

Multi-byte fields are encoded following a “big-endian” convention (“network order”). The order for the transmission of bytes is the same as the left-to-right reading order, and bytes are numbered starting with 0.

Bits are numbered from left-to-right, starting at 7 and ending at 0, with bit 7 representing the most significant bit (MSB).

Example

Byte	0								1								2...		
Bit	7	6	5	4	3	2	1	0	7	6	5	4	3	2	1	0	7	6	...
Value	MSB	...						LSB	MSB	...						LSB	MSB	...	

The digits in the document are written in English notation using ‘.’ as decimal separator and ‘,’ as a separator for large numbers. Example: 1,023.42

2. Protocol Description

2.1 General architecture

The Bluetooth® Low Energy communication in TRW devices provides two different operating modes.

Advertising Mode

- Identify a device.
- Provide data at regular time intervals (Logging).
- Enter connected mode.

Connected Mode

- Detailed Device information.
- Customize the device.
- Send Commands.

2.2 Device compatibility

The device is compatible with Bluetooth® Low Energy 4.2 and newer versions. For the connected mode, the communication partner must support BLE Secure Pairing with Passkey.

2.3 Bluetooth® password protection

To connect to the TRW device each product has been assigned an individual 6-digits password. The password is provided in the Quick Start Guide documents packed in a red envelope in your device packaging. When connected to the device, the password can be changed by the user.

The device allows up to 5 tries to enter the correct password during the pairing process. After that the device will be locked. After interrupting the power supply or removing the battery, 5 attempts are available again. If this is not possible for technical reasons, e.g. because the sensor cannot be reached to open the housing, contact technical support.

3. Advertising mode

3. Advertising mode

Advertising frames are sent every 1,25 seconds. Please note that the measured value is only updated in the configured measurement period.

The advertising data follows a format for organizing data similar to the TLV (Type, Length, Value) format used in data communication, except that the length comes before the type:

Advertising Data Structure		
Length	AD Type	AD Data

Two data structures are used, one for the device name and the other one to represent the sensor data. Each advertising message has a total length of 31 bytes.

3.1 Device name

The device name consists of 11 ASCII bytes. By default, after production, it represents the device serial number but can also be changed depending on individual needs (e.g. to represent a specific measuring point).

Bluetooth® SIG AD type: 0x09 Complete Local Name

AD Structure for Device name		
Length	AD Type	AD Data
0x0C	0x09	“Device Name”

3.2 Sensor data

The measured sensor value is included in the advertising by default. The data can also be hidden using the “[Hide Advertising Data](#)” characteristic described in the configuration service. In this case Byte 4...9 are not transmitted.

Bluetooth® SIG AD type: 0xFF Manufacturer Specific Data

AD Structure for Sensor data		
Length	AD Type	AD Data
0x0C	0xFF	See specific payload below

3. Advertising mode

Sensor data Payload

Byte	Name	Note
0-1	BLE manufacturer ID	0x0989: WIKA manufacturer ID
2	Product ID	16 = BLE + LPWAN version 17 = BLE only version
3	Product Sub ID	Sensor ID Bit [4...0]: 2 = TRW LPWAN ID Bit [7...5]: 0 = No LPWAN 1 = MIOTY 2 = LoRaWAN®
4	Status byte	Alarm status: Bit 0: Process Alarm ongoing Bit 1: Technical alarm Bit 2: Device alarm Bit 3: Measurement input alarm Update counter Bit [7...4]: Incremented by one on each change on measure or alarm status
5	Measuring Unit	See Appendix A
6-9	Measurement Value	32 bits float value (LSB first) of the sensor value
10	Battery Level	% of remaining capacity For externally powered devices, value is set to 0x80

4. Connected mode

4.1 GATT general description

To establish a two-way communication via Bluetooth[®], a connection based on the GATT (Generic Attribute Profile) protocol is required. The peripheral device can only connect to one central device (e.g. Smartphone) at the same time. During a connection, Advertising frames are no longer published.

The device provides three services adopted from the SIG and three custom services.

4.2 Adopted Services

The following Bluetooth[®] SIG standard services are integrated in the device. For more information, please refer to the specification on the Bluetooth[®] website.

- Generic Access Service (GAP)
- Battery Service
- Device Information Service

4.3 Custom Services

In the following service description, the following terminology is used:

- R Read action is possible
- W Write action is possible
- N Notification is possible

The “Notify” action permits to update the data automatically without activating the “Read” function each time data is updated.

4. Connected mode

4.3.1 Configuration Service

The configuration service allows configuration of the device including alarm and transmission parameters. For details how to configure the device via Bluetooth® please also refer to chapter 4.4.

Characteristic	UUID	Format	Length [Bytes]	Unit	Type	Description
Measure Unit	F13A300D164C469787E9EDF95FD0653F	uint8	1	-	R/W	This value reflects the sensor Measuring unit (Appendix A)
Offset	F13A300A164C469787E9EDF95FD0653F	float	4	Measure Unit	RW	Measuring value Offset
Gain	F13A300E164C469787E9EDF95FD0653F	float	4	-	RW	Measuring value Gain
Calibration Date	F13A300F164C469787E9EDF95FD0653F	uint8[]	3	-	R/W	Device Calibration Date Format: [YY, MM, DD]
Calibration range start	F13A3010164C469787E9EDF95FD0653F	float	4	Measure Unit	R/W	Calibrated measuring range limit start
Calibration range end	F13A3011164C469787E9EDF95FD0653F	float	4	Measure Unit	R/W	Calibrated measuring range limit end

4. Connected mode

Characteristic	UUID	Format	Length [Bytes]	Unit	Type	Description
Alarm Configuration	F13A3001164C469787E9EDF95FD0653F	uint8	1	Bitfield	R/W	Enable or disable alarms: Bit 0: Low threshold Bit 1: High Threshold Bit 2: Low slope Bit 3: High slope Bit 4: Delayed Low threshold Bit 5: Delayed High threshold Bit = 1 → Enabled
Low Alarm threshold	F13A3002164C469787E9EDF95FD0653F	float	4	<u>Measure Unit</u>	R/W	Low threshold value when the alarm will be activated.
High Alarm threshold	F13A3003164C469787E9EDF95FD0653F	float	4	<u>Measure Unit</u>	R/W	High threshold value when the alarm will be activated.
Falling Alarm slope	F13A3004164C469787E9EDF95FD0653F	float	4	<u>Measure Unit</u>	R/W	Low slope value when the alarm will be activated.
Rising Alarm slope	F13A3005164C469787E9EDF95FD0653F	float	4	<u>Measure Unit</u>	R/W	High slope value when the alarm will be activated.
Delayed Low Alarm threshold	F13A3006164C469787E9EDF95FD0653F	float	4	<u>Measure Unit</u>	R/W	Delayed Low threshold value when the alarm will be activated.
Delayed Low Alarm delay	F13A3007164C469787E9EDF95FD0653F	uint16	2	Seconds	R/W	Delay value for delayed low threshold alarm

4. Connected mode

Characteristic	UUID	Format	Length [Bytes]	Unit	Type	Description
Delayed High Alarm threshold	F13A3008164C469787E9EDF95FD0653F	float	4	<u>Measure Unit</u>	R/W	Delayed High threshold value when the alarm will be activated.
Delayed High Alarm delay	F13A3009164C469787E9EDF95FD0653F	uint16	2	Seconds	R/W	Delay value for delayed high threshold alarm
Dead band	F13A300B164C469787E9EDF95FD0653F	float	4	<u>Measure Unit</u>	R/W	Hysteresis value for the threshold alarms
Configuration ID	F13A1001164C469787E9EDF95FD0653F	uint8	1	-	R	A new configuration ID is generated automatically for each new configuration.
Measurement period with alarm	F13A1002164C469787E9EDF95FD0653F	uint32	4	Seconds	R/W	Measurement period when ≥ 1 alarm is active
Measurement period no alarm	F13A1003164C469787E9EDF95FD0653F	uint32	4	Seconds	R/W	Measurement period when no alarms are active
Transmission multiplier with alarm	F13A1004164C469787E9EDF95FD0653F	uint16	2	-	R/W	Transmission period = measurement period * transmission multiplier

4. Connected mode

Characteristic	UUID	Format	Length [Bytes]	Unit	Type	Description
Transmission multiplier no alarm	F13A1005164C469787E9EDF95FD0653F	uint16	2	-	R/W	Transmission period = measurement period * transmission multiplier
Command Status	F13A1006164C469787E9EDF95FD0653F	uint8	1		R/W/N	See Chapter 4.4
Hide advertising data	F13A1008164C469787E9EDF95FD0653F	bool	1	-	R/W	0 = Advertising frame contains measurement data 1 = Advertising frame does not contain measurement data
Custom BLE Name	F13A1009164C469787E9EDF95FD0653F	utf8[]	0-11	-	R/W	Device name in Advertisement frame. When this field is empty, the device serial number is used.
BLE Security Key	F13A100A164C469787E9EDF95FD0653F	utf8[]	6	-	R/W	6-digit Passkey for pairing with the device

4. Connected mode

4.3.2 Product Status Service

Measurement status information

Characteristic	UUID	Format	Length [Bytes]	Unit	Type	Description
Measurand	B75C300D3BBC4FB7A7EA37BA44F4C0B0	uint8	1	-	R	Physical measurand (Appendix B)
Accuracy	B75C300A3BBC4FB7A7EA37BA44F4C0B0	uint16	2	0.001%	R	Device Accuracy
Process Alarm status	B75C30013BBC4FB7A7EA37BA44F4C0B0	uint8	1	-	R/N	Active alarm bitfield: Bit 0: Low threshold Bit 1: High threshold Bit 2: Falling slope Bit 3: Rising slope Bit 4: Low threshold with delay Bit 5: High threshold with delay
Measurement Input Failure Alarm Status	B75C300B3BBC4FB7A7EA37BA44F4C0B0	uint8	1	-	R/N	Bit 0: General Error Bit 1: Sensor Warning 1 Bit 2: Meas. Limit High Bit 3: Meas. Limit Low Bit 4: Sensor Warning 2
Measure Value	B75C30003BBC4FB7A7EA37BA44F4C0B0	float	4	<u>Measure Unit</u>	R/N	Value measured by the device. Note: Value is updated in the configured measurement period only.

4. Connected mode

Characteristic	UUID	Format	Length [Bytes]	Unit	Type	Description
Alarm threshold	B75C30023BBC4FB7A7EA37BA44F4C0B0	float	4	<u>Measure Unit</u>	R/N	In case of rising or falling threshold alarm: Device sensor value when alarm condition is raised.
Delayed Alarm threshold	B75C30033BBC4FB7A7EA37BA44F4C0B0	float	4	<u>Measure Unit</u>	R/N	In case of delayed rising or falling threshold alarm: Device sensor value when alarm condition is raised.
Alarm Slope	B75C30043BBC4FB7A7EA37BA44F4C0B0	float	4	<u>Measure Unit</u>	R/N	In case of rising or falling slope alarm: Computed slope value when alarm condition is raised.
Measurement Range Start	B75C30053BBC4FB7A7EA37BA44F4C0B0	float	4	<u>Measure Unit</u>	R	Start of device measuring range
Measurement Range End	B75C30063BBC4FB7A7EA37BA44F4C0B0	float	4	<u>Measure Unit</u>	R	End of device measuring range
Measure min. range limit	B75C30083BBC4FB7A7EA37BA44F4C0B0	float	4	<u>Measure Unit</u>	R	Minimum physical measuring limit
Measure max. range limit	B75C30093BBC4FB7A7EA37BA44F4C0B0	float	4	<u>Measure Unit</u>	R	Maximum physical measuring limit

4. Connected mode

Device status information

Characteristic	UUID	Format	Length [Bytes]	Type	Description
BLE MAC address	B75C10013BBC4FB7A7EA37BA44F4C0B0	uint8[]	6	R	Bluetooth® module MAC address
BLE Version	B75C10023BBC4FB7A7EA37BA44F4C0B0	utf8	3	R	BLE specification version
LPWAN EUI	B75C10033BBC4FB7A7EA37BA44F4C0B0	uint8[]	8	R	In case of an LPWAN device: LoRaWAN® DevEUI
LPWAN Version	B75C100A3BBC4FB7A7EA37BA44F4C0B0	uint8[]	5	R	LPWAN specification version
LoRaWAN® AppEUI	B75C10093BBC4FB7A7EA37BA44F4C0B0	uint8[]	8	R	LoRaWAN® AppEUI
LoRaWAN® Join Status	B75C10073BBC4FB7A7EA37BA44F4C0B0	bool	1	R/N	True if Device has joined a network
Technical Alarm Status	B75C10043BBC4FB7A7EA37BA44F4C0B0	uint8	1	R/N	Internal failure status code
Device Alarm Status	B75C10053BBC4FB7A7EA37BA44F4C0B0	uint8	1	R/N	Bit 0: Low Battery Bit 2: LPWAN Duty Cycle Bit 3: Internal Error All others reserved
Battery Voltage	B75C10063BBC4FB7A7EA37BA44F4C0B0	uint16	2	R	Battery Voltage in mV Devices with external power: 0xFFFF
Article number	B75C100B3BBC4FB7A7EA37BA44F4C0B0	utf8	10	R	Device Article number

4. Connected mode

4.3.3 Data Logging Service

The TRW device is keeping track of all Process alarms that appear and stores them in a list together with the corresponding measurement value. The log file can be retrieved via Bluetooth® using the following procedure.

A maximum of 256 log entries can be stored in a ring buffer style.

The Request commands will open a logging retrieve session window. The session has a timeout of 30s which is restarted with each following command. After the timeout or when the close command is sent, the complete log buffer will be cleared automatically (One time read only!)

Characteristic	UUID	Format	Length [Bytes]	Type
Logging Command	0A40000098FE43598EC97CCE2662D06F	Uint8	35	R/W/N

Command Table

Command	Description
0x00	Request data logging info table
0x01	Request data logging data
0x02	Close logging session

Step 1: Request data logging information

Writing the command value 0x00 to the Logging command will request the data logging information table answer containing an overview of the active alarms:

Byte	Field	Note
0	Response	0x80: Get data logging information table
1	Last packet indicator	While cleared, the 0x00 command need to be sent to get the whole table of information. When set to 1, the packet contains the last information table element
2	Payload length	The length of the whole payload excluding Command field, Last packet field and Payload length field
3	Alarm x ID	An arbitrary generated alarm ID unique for each alarm
4-5	Alarm x Start index	The start index into the data table for this alarm (index starting at 0)
6-7	Alarm x End index	The end index into the data table for this alarm (index starting at 0)

4. Connected mode

8-11	Alarm x code	The alarm status according encoding in Product Status Service with: Alarm x code [31] – Internal Failure Alarm Status Alarm x code [30...25] – Reserved (0) Alarm x code [24...16] – Measurement Input Alarm Status Alarm x code [15...8] – Reserved (0) Alarm x code [7...0] – Process Alarm Status
11...	The total package size of 35 byte is filled with the next Alarm IDs if available.	
The Alarm x ID + Alarm x Start index + Alarm x End index + Alarm x code are repeated for the total number of alarms with x = 1 to x = number of alarms		

Example

Command: 00

Response:

80 → Get data logging info
01 → Last package
12 → Payload length (18 byte)
00 → Alarm ID 0
00 00 → Start Index
04 00 → End Index
00 00 00 01 → Process Alarm, Low Threshold
01 → Alarm ID 1
00 00 → Start Index
04 00 → End Index
00 01 00 00 → Measurement Input, General Error

4. Connected mode

Step 2: Request data logging data

Writing the command value 0x01 to the Logging command will request the data logging data table containing the measurement data when the respective alarm ID occurred:

Byte	Field	Note
0	Response	0x81: Get data logging data table
1	Last packet	While cleared, the 0x01 command need to be sent to get the whole table of data. When set to 1, the packet contains the last logging data element
2	Payload length	The length of the whole payload excluding Command field, Last packet field and Payload length field
3 - 6	Measurement Value	Measurement value of sensor as Float in sensor unity encoded MSB first
7-10	Reserved	Reserved for future use
11...	The total package size of 35 byte is filled with the next Alarm values if available.	

Note:

No information is stored which sensor type was selected when the alarm occurred. It is recommended to clear the error log after the sensor type has been changed.

Example

Command: 01

Response:

81 → Get data logging data
01 → Last package
10 → Payload length:
41 BC 00 00 → Measurement value Alarm ID 0: 23.5
00 00 00 00 → Reserved
40 16 66 66 → Measurement value Alarm ID 1: 2.35
00 00 00 00 → Reserved

Step 3: Close data logging session

Writing the command value 0x02 to the Logging command will close the data logging session.

Byte	Field	Note
0	Response	0x82: Logging session closed

4. Connected mode

4.4 Device Commands

Via the Command Status characteristic in the configuration service, multiple device commands can be triggered. Also, any changes of the device configuration are only applied using the respective command. Each command is answered with a corresponding status that informs about success or failure.

Device Commands

Value	Command	Description
1	Apply Config	Applies all configuration parameters that have been changed.
2	Force LoRaWAN [®] Join	Triggers a LoRaWAN [®] Join Request if not yet connected to a network.
3	Force Data Transmission	Sends the current measurement value via LPWAN.
4	Factory config	Reset device to factory settings.
5	Force Measurement	Refresh measurement value.
6	Reset Energy Counter	Reset energy counter after battery has been replaced.

Return Status

Value	Description
0x80	Command Success
0x81	Error, unknown command
0x82	Device busy
0x83	Configuration check failed
0x84	Error writing Settings

Appendix

A. Unit Identifier

Unit ID (dec)	Description
1	[°C] degree Celsius
2	[°F] degree Fahrenheit

B. Measurand IDs

Measurand ID (dec)	Description
1	Temperature

LoRaWAN® is a trademark used under licence from LoRa Alliance®

The Bluetooth® word mark and logos are registered trademarks owned by Bluetooth SIG, Inc. and any use of such marks by WIKA is under license. Other trademarks and trade names are those of their respective owners.

WIKA subsidiaries worldwide can be found online at www.wika.com.



Importer for UK
WIKA Instruments Ltd
Unit 6 & 7 Goya Business park
The Moor Road
Sevenoaks
Kent • United Kingdom
TN14 5GY



WIKA Alexander Wiegand SE & Co. KG
Alexander-Wiegand-Straße 30
63911 Klingenberg • Germany
Tel. +49 9372 132-0
Fax +49 9372 132-406
info@wika.de
www.wika.de

**LPWAN communication protocol, model TRW
(EU868, IN865)**

EN



© 1/2026 WIKA Alexander Wiegand SE & Co. KG

All rights reserved.

WIKA[®] is a registered trademark in various countries.

Prior to starting work, read the operating instructions!

Keep for later use!

Content

1. General Information	4
1.1 Abbreviations and Definitions	4
1.2 Scope of this Document	4
1.3 Conventions	5
2. Application Protocol Description	6
2.1 Purpose	6
2.2 Protocol Key-Points	6
2.3 Measurement Encoding	7
2.4 Process Alarms	9
2.5 Configuration Identifier	13
2.6 Typical Product Behaviour	14
3. Upstream Messages	15
3.1 General Format	15
3.2 Data Message with or without ongoing Alarm	16
3.3 Process Alarm Message	17
3.4 Technical Alarm Message	19
3.5 Device Alarm Message	20
3.6 Configuration Status Message	21
3.7 Device Identification Message	23
3.8 Keep-Alive Message	25
3.9 Measurement Input Failure Alarm Message	26
4. Downstream Messages	27
4.1 General Format	27
4.2 Reset to factory configuration command	28
4.3 Set main configuration	29
4.4 Get main configuration	30
4.5 Reset battery indicator	30
4.6 Set process alarm configuration	31
4.7 Get process alarm configuration	32
5. Connectivity protocol: LoRaWAN®	33
5.1 Radio network integration	33
5.2 Join procedure	33
5.3 LoRaWAN® ports	33
5.4 Message Confirmation	34

6. Connectivity Protocol: mioty	35
6.1 Radio network integration	35
6.2 Device behaviour	35

1. General Information

1. General Information

Note:

This protocol description applies to all TRW devices using the EU868 or IN865 LoRaWAN® regional parameter set. If you are using devices with a different regional parameter configuration, please refer to the relevant protocol documentation.

1.1 Abbreviations and Definitions

LPWAN	Low-power wide-area network, a category of wireless digital data network.
Network	In this document, LPWAN for which a specific device is designed, and configured to communicate with.
Packet	A unit of radio transmission; it can contain LPWAN network management data, as well as zero, one, or several messages following the application protocol described in the present document.
Platform	Generic term for the data processing and storage system that will bring meaning to the data sent by the device.
Alarm	In this document, “alarm” is used as a generic technical term for condition-based packets sent by the device and do not assume any level of severity.
Process Alarm	Alarm related to the measurement value
Technical Alarm	Alarm related to the overall instrument status as well as the quality and reliability of the measurement of each channel

1.2 Scope of this Document

This technical guide describes the LPWAN communication protocol used by the model TRW. It is intended both for developers who are designing a protocol interpreter for the product and for those seeking a comprehensive understanding of the capabilities of this WIKA product. The document covers both available TRW LPWAN versions, LoRaWAN® and mioty.

1. General Information

1.3 Conventions

As a convention, all the traffic that is sent wirelessly from a connected device to the network (via one or several gateways) is called “upstream traffic” or “Uplink” and all the traffic that is sent wirelessly by the network to a device is called “downstream traffic” or “Downlink”. Multi-byte fields are encoded following a “big-endian” convention (“network order”). The order for the transmission of bytes is the same as the left-to-right reading order, and bytes are numbered starting with 0.

Bits are numbered from left-to-right, starting at 7 and ending at 0, with bit 7 representing the most significant bit (MSB).

Example

Byte	0								1								2...		
Bit	7	6	5	4	3	2	1	0	7	6	5	4	3	2	1	0	7	6	...
Value	MSB	...						LSB	MSB	...						LSB	MSB	...	

The digits in the document are written in English notation using ‘.’ as decimal separator and ‘,’ as a separator for large numbers. Example: 1,023.42

2. Application Protocol Description

2. Application Protocol Description

2.1 Purpose

The purpose of the application protocol is to enable the device to communicate with an IIoT platform where the data can be used for storage, and further processing.

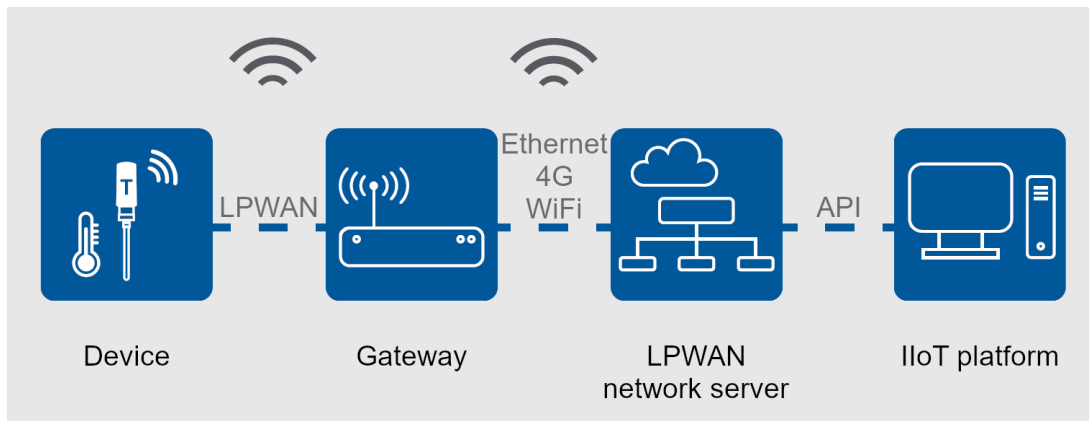

The protocol was designed to be compact to minimise the energy consumption (for longer battery life) and use the shared radio spectrum more efficiently to enable more instruments to be connected to a given network.

The translation, in the upstream and downstream directions, between this optimised, binary, context-dependent protocol, and a more versatile high-level protocol chosen by the customer for data processing, storage and display is performed by a software component called the protocol decoder.

2.2 Protocol Key-Points

- The device “wakes up” at adjustable time intervals to acquire a measurement point. The measured value is then checked for specific user-defined conditions (process alarms).
- One out of every N (user defined) measurement point is transmitted to the platform.
- The device sleeps most of the time to save power. One or more user-defined commands to change its configuration can be received at the end of each uplink transmission.
- Should the device encounter any anomaly during internal self-tests, alarm messages will be generated and transmitted.

2. Application Protocol Description

2.3 Measurement Encoding

Device measurement data is expressed on a generic unitless scale [2,500...12,500] (encoded as a 16-bit integer) corresponding to the default full scale. One unit of measurement is equivalent of 0.01 % of the span of the instrument. Process alarm thresholds are expressed on the same scale.

The starting value 2,500 will correspond to the Measuring Range Start (MRS) of the TRW.

The ending value 12,500 will correspond to the Measuring Range End (MRE).

The conversion between unitless digital data and the physical value is performed using the following formula:

$$physical\ value = \left(\left(\frac{digital\ value - 2,500}{10,000} \right) * span \right) + start\ of\ measuring\ range$$

Where the span of the device is defined using the following formula:

$$span = end\ of\ measuring\ range - start\ of\ measuring\ range$$

From a protocol standpoint, data is considered valid between 0 and 15,000 (decimal) allowing values of -25 % to 125 % of the instrument's measurement range to be encoded.

Please be aware: This does not imply the instrument is actually capable of covering this extended span.

Accuracy outside of the instrument's measurement range will typically be degraded or unspecified.

For the TRW, the span and start of the measurement range is variable and depends on the measurement range ordered by the customer.

The resolution of the encoding used for data transmission (0.01 % of span) is generic and must not be confused with the resolution and accuracy of the instrument.

Please refer to the documentation of your instrument for technical specifications and information about accuracy, usable range, safety limits, etc.

2. Application Protocol Description

Example

A digital value of 4,500 on a TRW sensor with a range of -200...850 °C corresponds to a physical value of 10 °C.

$$\text{span} = 850\text{ }^{\circ}\text{C} - (-200\text{ }^{\circ}\text{C}) = 1050\text{ }^{\circ}\text{C}$$

$$\text{physical value} = \left(\left(\frac{4,500 - 2,500}{10,000} \right) * 1050\text{ }^{\circ}\text{C} \right) + (-200\text{ }^{\circ}\text{C})$$

$$\text{physical value} = 10\text{ }^{\circ}\text{C}$$

The following table gives more examples of data representation:

Device	16-bit data value (or alarm threshold)			
	0x09C4 = 2,500 dec	0x30D4 = 12,500 dec	0x0CB3 = 3,251 decimal (3,251 - 2,500) * 0.01 % = 7.51 % of span	0x2DD2 = 11,730 decimal (11,730 - 2,500) * 0.01 % = 92.30 % of span
TRW	min. => -200 °C	max. => 850 °C	(7.51 % * span) - 200 = -121.15 °C	(92.3 % * span) - 200 = 769.15 °C

2. Application Protocol Description

2.4 Process Alarms

Process alarms are a feature of the device. Each time a measurement is taken, the measured value and slope (defined as currently measured value – previous value) can be compared to user-defined thresholds. If a value is outside of a threshold, a message will immediately be transmitted to the network without waiting for the normal transmission interval.

As taking a measurement requires only a fraction of the energy needed for transmitting it, the use of process alarms in combination with measurement and transmission periods that are different from each other enables energy-saving strategies.

Configuring alarms when the measurement and transmission periods are equal provide little to no benefit as all measurement points will be available to the platform, and various condition-based triggers can be implemented here. Similarly, configuring different periods for measurement and transmission without configuring any process alarm increase energy usage with little to no gain.

There are three different types of process alarms, each in two “directions” that can be configured:

Process alarm	Parameters		
	Threshold	Dead band ¹	Delay
High threshold	Value [2,500 ... 12,500]	Value [0 ... 10,000]	n/a
Low threshold	0.01 % of span	0.01 % of span	n/a
High threshold with delay			Value [1 ... 65,535] in units of 1 s
Low threshold with delay			
Rising slope	Value [0 ... 10,000] ²	n/a	n/a
Falling slope	0.01 % of span/minute	n/a	n/a

¹ Dead band setting is common to all alarms.

² Slope Threshold is defined as an absolute value and the direction defined by the rising/falling alarm.

2. Application Protocol Description

2.4.1 High Threshold Alarm

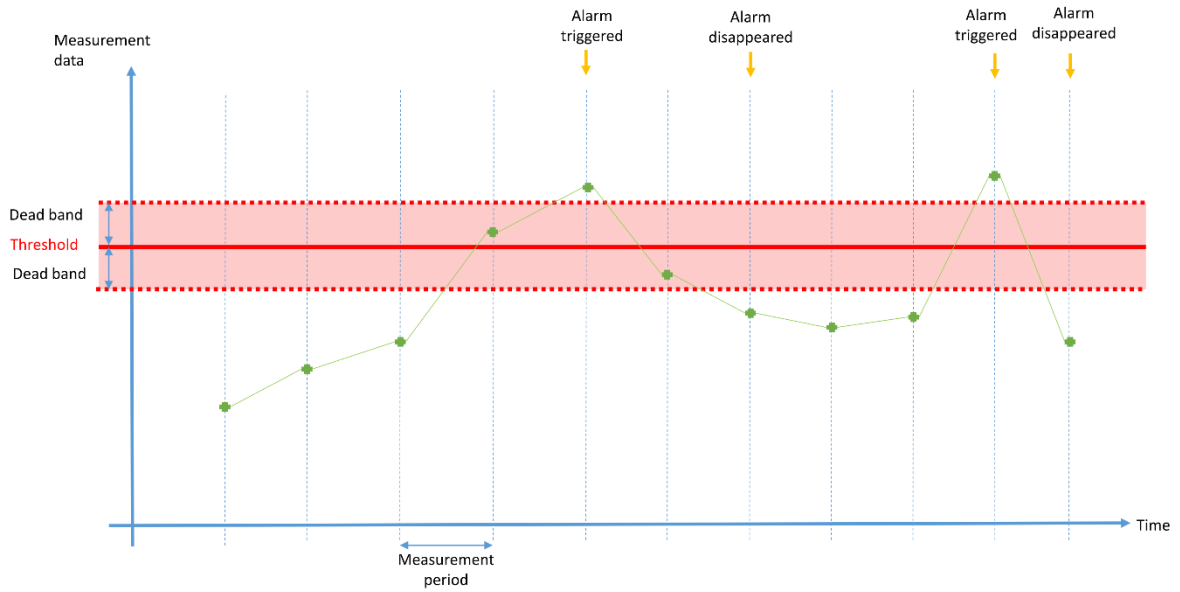

2.4.2 Low Threshold Alarm

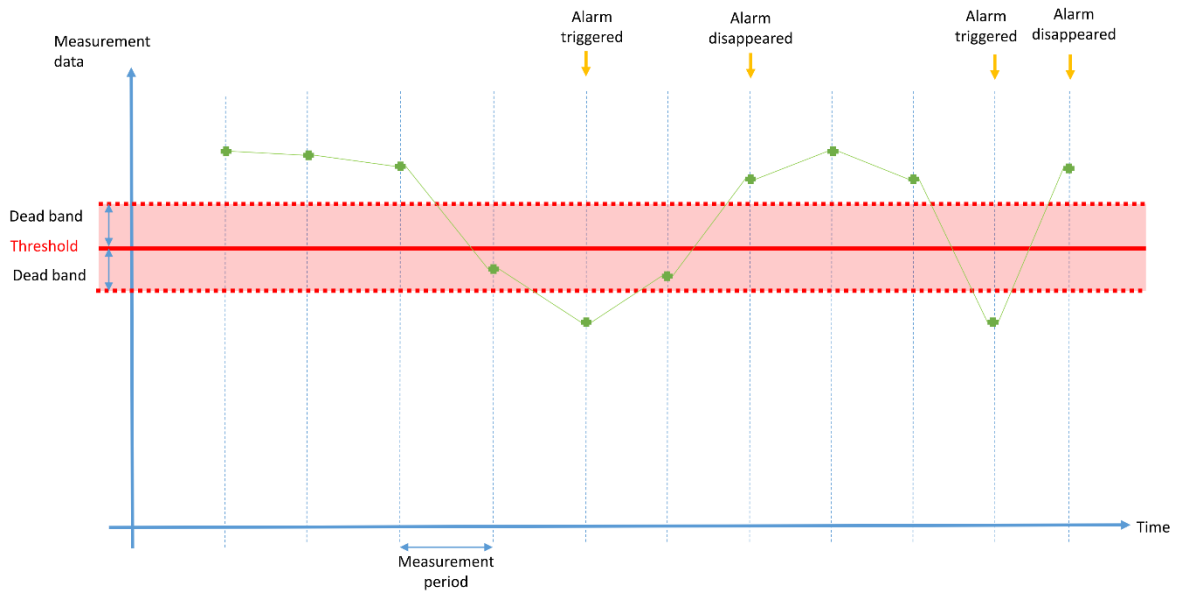

2. Application Protocol Description

2.4.3 High Threshold Alarm with Delay

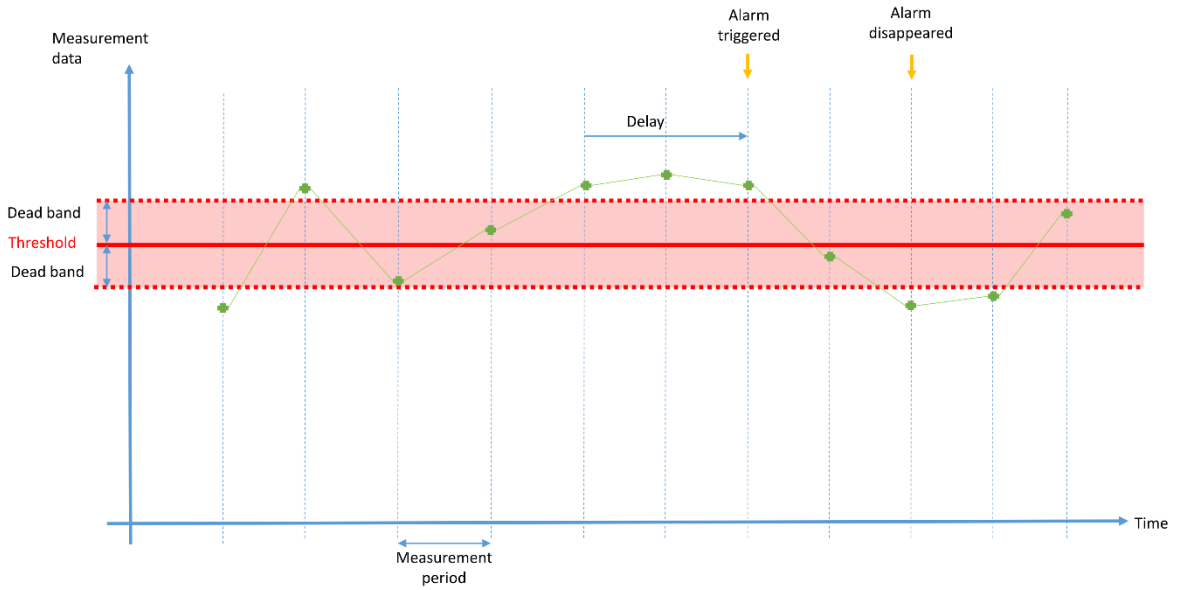

2.4.4 Low Threshold Alarm

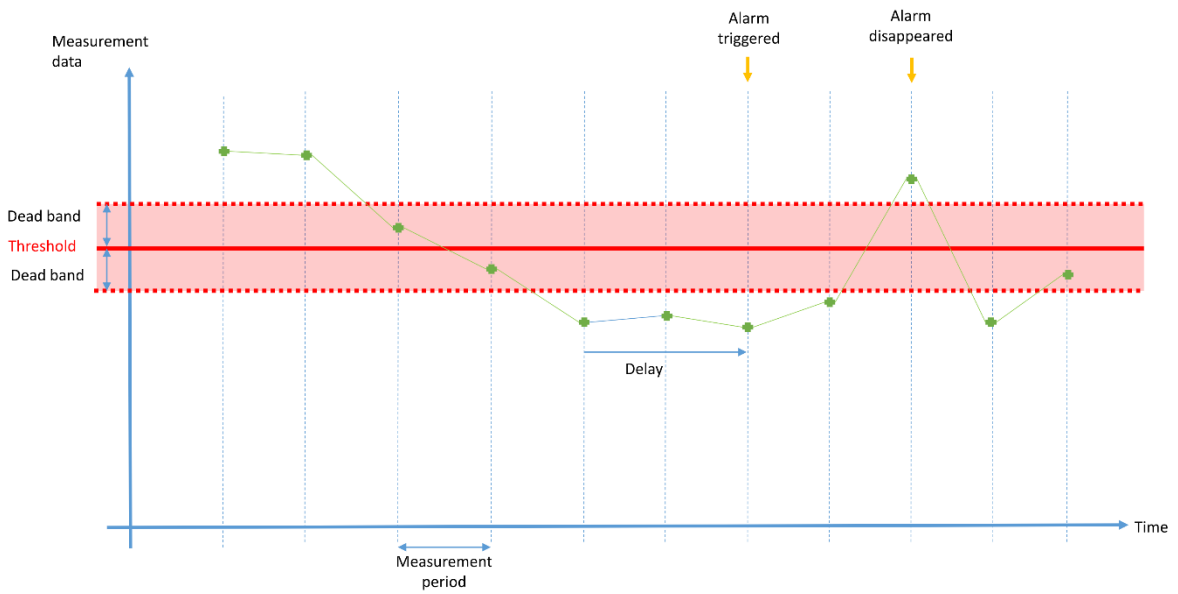

2. Application Protocol Description

2.4.5 Rising Slope Alarm

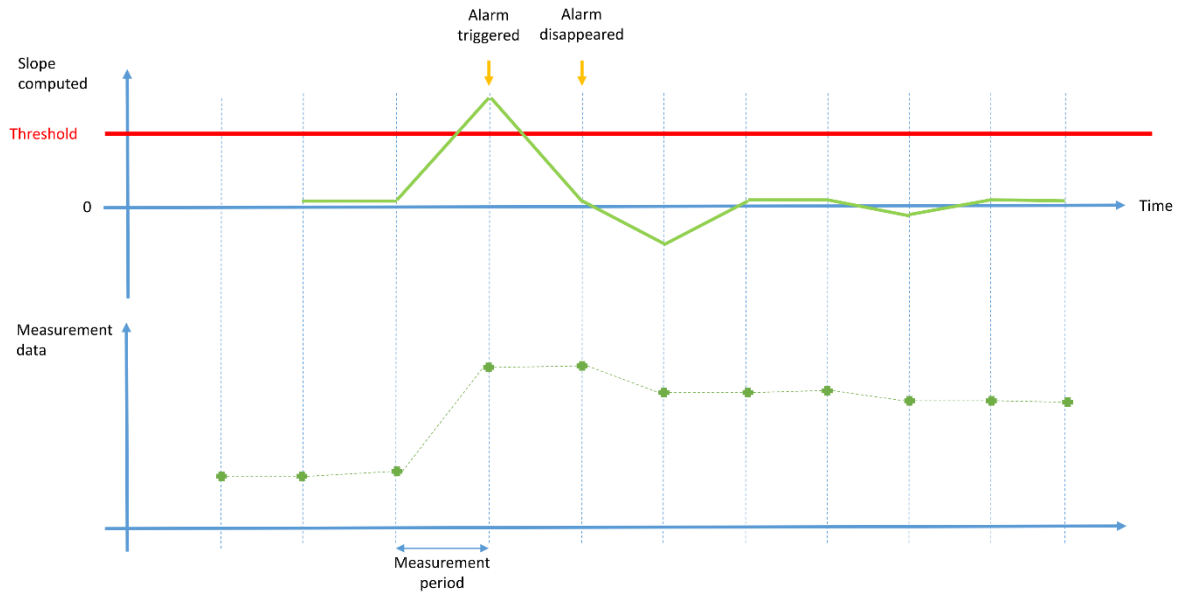

2.4.6 Falling Slope Alarm

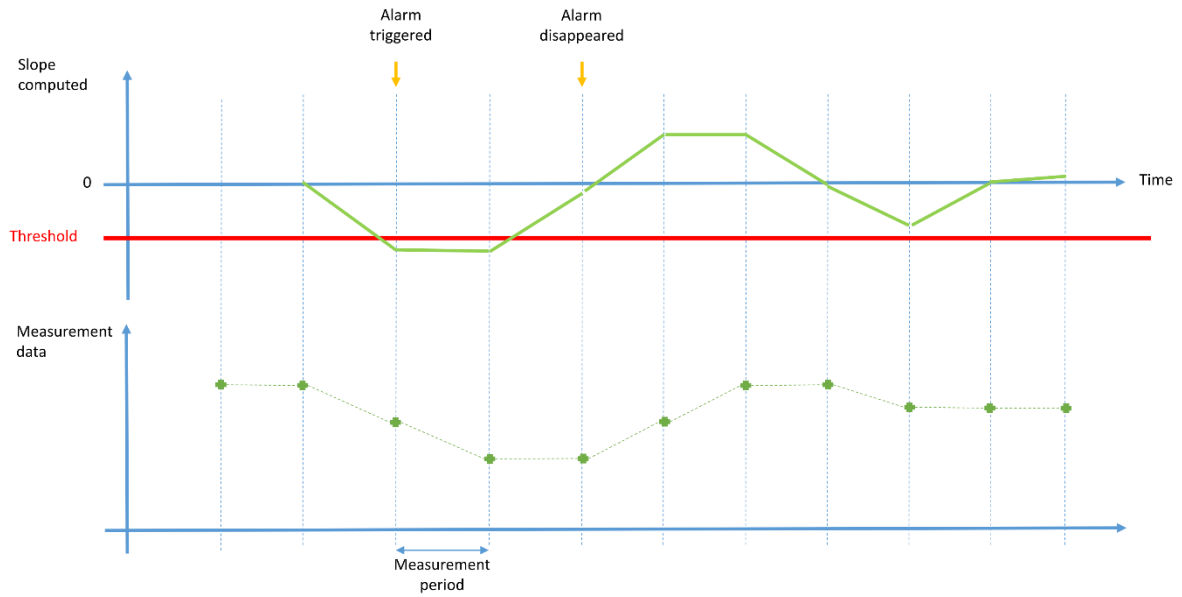

2. Application Protocol Description

2.5 Configuration Identifier

The model TRW can be configured remotely using LPWAN or Bluetooth® to suit the application. Several parameters such as measurement period, transmission period, alarms, etc. can be set.

To interpret the meaning of upstream messages, the IIoT platform needs to know the configuration currently active in the device. This is why all upstream messages include a “Configuration Identifier” (Config ID) and all downstream packets, that can contain several commands changing the device configuration include a “transaction identifier” (Transaction ID). One Bit in the Config ID byte is used to indicate the platform that the configuration has been changed locally using the Bluetooth® interface.

The Config ID Byte is composed as follows:

Bit	7	6	5-0
Description	Reserved	Local Configuration Indicator	Configuration Identifier

When a downstream packet with transaction identifier X results in a change of configuration of the device (configuration successful) then all the following upstream packets will use value X as Config ID.

So, when a new configuration is sent, the platform should select a value for the transaction ID between 1 and 63, which is different from the current Config ID of the TRW. Using a sequential value is convenient but not mandatory. Value 0 is, by convention, used to indicate the factory configuration, and thus shall be used as a transaction ID when sending a “reset to factory configuration” command.

Values above 63 are reserved and must be avoided. After value 63 is reached, next value should be 1 (roll-over) by convention.

2. Application Protocol Description

2.6 Typical Product Behaviour

The figure below represents the temporal behaviour of a TRW device when a measured value of a data channel is fluctuating and a high threshold process alarm is configured:

Radio unit activity (including confirmed and unconfirmed packets)

Active phases exaggerated for clarity, typically they last for milliseconds to seconds while sleep phases last from a few minutes to several hours

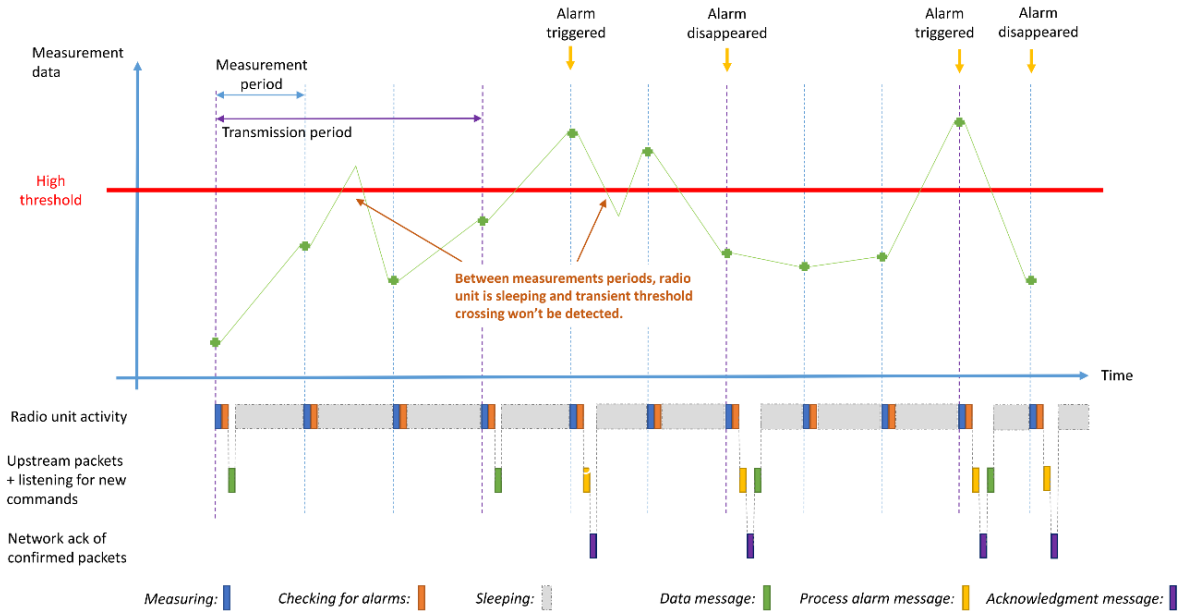

It shows, that in practice the device sleeps most of the time and wakes up only for short moments to record the measured value, check if user-defined alarm conditions are present or not and periodically send and receive data from the LPWAN network.

3. Upstream Messages

3. Upstream Messages

3.1 General Format

Upstream messages are sent wirelessly by the TRW device to the network and interpreted by the IIoT platform. Each upstream LPWAN packet contains a single message as its payload.

The packet format is as follows:

Byte	Note
0	Message type, see next table for details
1	Current configuration identifier (config ID) ³
2...n	Content of the message, depending on message type

The first byte of the message describes its type:

Value (hex)	Upstream message types
0x01	Data message with no alarm ongoing
0x02	Data message with at least one alarm ongoing
0x03	Process alarm message
0x04	Technical alarm message
0x05	Device alarm message
0x06	Configuration status message
0x07	Device identification message
0x08	Keep alive message
0x0A	Measurement input failure alarm message
0x0B	Main configuration status message (mioty only)
0x0C	Process Alarm Configuration message (mioty only)
0x0D	Channel Property Configuration message (mioty only)

³ For the configuration status message (chapter 2.5), the TRW uses the transaction ID of the packet it is responding to instead of the current configuration ID.

3. Upstream Messages

3.2 Data Message with or without ongoing Alarm

The data message contains the latest value measured by the device. In case of an error during the measurement the data value will be set to 0xFFFF.

The message is formatted as follows:

Byte	Value	Note
0	Data message type	In accordance with upstream messages type table (0x01, 0x02)
1	Config ID	Current configuration identifier
2	0x00	Reserved
3-4	Data value	2500...12500 value (unit 0.01 %)

3.2.1 Example 1

Upstream packet: 0x01 00 00 2E 97

Decoding	
01	Data message, no alarm ongoing
00	Configuration ID = 0, TRW is using the factory configuration
00	Reserved
2E 97	Measurement value at 94.27 % of span

3.2.2 Example 2

Upstream packet: 0x02 07 00 1E B0

Decoding	
02	Data message, at least one alarm is active
07	Configuration ID = 7
00	Reserved
1E B0	Measurement value at 53.56 % of span

3. Upstream Messages

3.3 Process Alarm Message

A process alarm message contains one or more process alarms that have been triggered or disappeared after a measurement. The message is event-based and depends on user configuration.

The message is formatted as follows:

Byte	Value	Note
0	0x03	Process alarm has been triggered and/or disappeared
1	Config ID	Current configuration identifier
2	0x00	Reserved
3	Alarm type	See alarm type table below
4-5	Related value	See related value table below

Alarm type

Bit	Description	Value
7	Sense	0: The latest measurement has triggered an alarm 1: The latest measurement has made an alarm disappeared
6	Reserved	Always 0
5-0	Alarm type	Bit 0: Low threshold Bit 1: High threshold Bit 2: Falling slope Bit 3: Rising slope Bit 4: Low threshold with delay Bit 5: High threshold with delay

3. Upstream Messages

Related Values

Process alarm type	Value
Low threshold	Triggering/disappearing value: 2,500...12,500 value (0.01 % of span)
High threshold	
Low threshold with delay	
High threshold with delay	
Falling slope	Triggering/disappearing slope, absolute value: 0...10,000 value (0.01 % span/minute)
Rising slope	

3.3.1 Example 1

Upstream packet: 0x03 11 00 00 0D 73

Decoding	
03	Process alarm message
11	Configuration ID = 17
00	Reserved
00	An alarm was triggered of the “Low threshold” type
0D 73	The measurement that triggered the alarm was at 9.43 % of span

3.3.2 Example 2

Upstream packet: 0x03 0F 00 88 00 D9

Decoding	
03	Process alarm message
0F	Configuration ID = 15
00	Reserved
88	Alarm disappeared, of the “Rising slope” type
00 D9	Slope that made the alarm disappear = +2.17 % of span/minute

3. Upstream Messages

3.3.3 Example 3

Upstream packet: 0x03 0F 00 20 2C A8 02 26 B8

Decoding	
03	Process alarm message
0F	Configuration ID = 15
00	Reserved
20	Alarm triggered, “High threshold with delay” type
2C A8	Measurement that triggered the alarm = 89.32 %
02	Alarm triggered, “High threshold” type
26 B8	Measurement that triggered the alarm = 74.12 %

3.4 Technical Alarm Message

This message signals an internal failure of the device.

The message is formatted as follows:

Byte	Value	Note
0	0x04	Technical alarm has been triggered
1	Config ID	Current configuration identifier
2	0x00	Reserved
3 - 4	Alarm type	Type of internal failure

3. Upstream Messages

3.5 Device Alarm Message

Device alarms are always enabled. They do not relate directly to the measurement itself but to the system health in general.

The message is formatted as follows:

Byte	Value	Note
0	0x05	Device alarm has been triggered
1	Config ID	Current configuration ID
2-3	Alarm type	See alarm type table below

Alarm Type

Bit	Description	Value
15-4	Reserved	0
3	Configuration Error	1: Internal configuration error, please contact WIKA service
2	Duty cycle alarm	1: RF emission duty cycle exceeded ⁴
1	Reserved	0
0	Low battery	1: Battery voltage below 2.7V. Please change battery soon.

3.5.1 Example

Upstream packet: 0x05 00 00 01

Decoding	
05	Device Alarm
00	Configuration ID = 0 (default)
0001	Low battery alarm triggered

⁴ This message is received *after* the device is forced to pause all communication for some times to respect regional legal limits of radio spectrum use. Loss of messages is possible.

3. Upstream Messages

3.6 Configuration Status Message

The configuration status message is sent by the device after receiving a command to inform the platform whether the command received was valid or not.

If additional information was requested, the data will also be transmitted with this message.

The message is formatted as follows:

Byte	Value	Note
0	0x06	Configuration status
1	Transaction ID	Transaction identifier used by the downstream packet the device is responding to
2	Response Status	See Response Status table below
3-n		Response data depending on Downstream Request

Response Status

Bit	Name	Description
7-4	Configuration Status Value	2: Configuration applied with success 3: Configuration rejected – At least one parameter is incorrect 6: Command Success (e.g. Battery reset, Get configuration, ...) 7: Command failed All others reserved.
3-0	Reserved	

3.6.1 Get main configuration response

Byte	Value	Note
4-7	Measurement period when no alarms are active	Period in seconds
8-9	Transmission multiplier when no alarms are active	Transmission period = measurement period * transmission multiplier
10-13	Measurement period when ≥ 1 alarm is active	See above
14-15	Transmission multiplier when ≥ 1 alarm is active	
16	0x00	Reserved

3. Upstream Messages

3.6.2 Get process alarm configuration response

Byte	Size (bytes)	Bit	Value	Note
4	1		0x00	Reserved, must always be 0x00
5	2		Dead band, common to all non-slope alarms	0...10,000 in increments of 0.01 % of span; common to all non-slope alarms
7	1	7	Alarm 1: Low threshold	For each alarm, the bit value means: 1: enabled 0: disabled
		6	Alarm 2: High threshold	
		5	Alarm 3: Falling slope	
		4	Alarm 4: Rising slope	
		3	Alarm 5: Low threshold with delay	
		2	Alarm 6: High threshold with delay	
		1-0	0	Reserved
8-23	2		Threshold value for alarm 1	Included only if the respective alarm is enabled (see Byte 7)
	2		Threshold value for alarm 2	
	2		Slope value for alarm 3	Thresholds in: 2,500...12,500 (0.01% of span)
	2		Slope value for alarm 4	
	2		Threshold value for alarm 5	Slope values in: 0...10,000 (0.01% of span/minute)
	2		Delay value for alarm 5	
	2		Threshold value for alarm 6	
	2		Delay value for alarm 6	

3.6.3 Example

Upstream packet: 0x06 03 20

Decoding	
06	Configuration Status message
03	Transaction ID = 3 (Device is responding to a configuration change with Transaction ID 3)
20	Configuration was accepted and applied

3. Upstream Messages

3.7 Device Identification Message

After joining a network, the device transmits a message that contains all the metrological information necessary to decode the data packets and identify the unit.

The message is formatted as follows:

Byte	Value	Note
0	0x07	Device identification message
1	Config ID	Current configuration identifier
2	Product ID	WIKA wireless product ID for model TRW = 0x0F = 16
3	Product sub-ID	Sensor ID [Bit 4...0]: 2: TRW LPWAN ID [Bit 7...5]: 0: Reserved 1: mioty® 2: LoRaWAN®
4-5	Device Firmware Version	MAJOR.MINOR.PATCH = v[0-15].[0-15].[0-255] Hex-Coded: 0xMmPP
6-7	Device Hardware Version	MAJOR.MINOR.PATCH = v[0-15].[0-15].[0-255] Hex-Coded: 0xMmPP
8-18	Device Serial Number	Alphanumeric (ASCII)
19-22	Measurement Range Start	Lower bound of measurement range Float – Big endian encoded
23-26	Measurement Range End	Upper bound of measurement range Float – Big endian encoded
27	Physical Measurand	See Measurand ID table below
28	Unit	See Unit identifier table below

3. Upstream Messages

Measurand IDs

Measurand ID (dec)	Description
1	Temperature

Unit identifier

Unit ID (dec)	Description
1	[°C] degree Celsius
2	[°F] degree Fahrenheit

3.7.1 Example

Upstream packet: 0x07 00 0F 42 0200 0100 3141324233433444354536 00000000
41200000 01 01

Decoding	
07	Device Identification
00	Configuration ID = 0 (default configuration)
0F	TRW Product ID = 16
42	Product sub-ID = 2 ⇒ TRW LoRaWAN® Version
0200	Firmware version = 0.2.0
0100	Hardware version = 0.1.0
3141324233433444354536	Serial Number: "1A2B3C4D5E6"
00000000	Min. Range = 0.0 (float)
41200000	Max. Range = 10.0 (float)
01	Measurand = Temperature
01	Unit = Celsius

3. Upstream Messages

3.8 Keep-Alive Message

The keep-alive frame is transmitted periodically every 24 hours. This setting is not adjustable. This guarantees that the device will be reachable at least once a day no matter how the transmission period is configured.

The message is formatted as follows:

Byte	Value	Note
0	0x08	Keep-alive message
1	Config ID	Current configuration identifier
2	Battery Status	Battery Event (Bit 7): 0: no Event 1: Device has restarted since the last keep-alive transmission Battery Level Indicator (Bit 6...0): Current estimated battery level in per cent (0-100) 0x7F: An error occurred during battery level computation. 0x7E: Device externally Powered

3.8.1 Example

Upstream packet: 0x08 00 3F

Decoding	
08	Keep Alive message
00	Configuration ID = 0 (default configuration)
3F	Battery Level estimation 63%, no additional battery event

3. Upstream Messages

3.9 Measurement Input Failure Alarm Message

This alarm type is always enabled and cannot be configured. It is related to the measurement signal input itself.

The message is formatted as follows:

Byte	Value	Note
0	0x0A	Measurement Input Failure Alarm message
1	Config ID	Current configuration identifier
2	0x00	Reserved
3-4	Alarm Type	See Alarm Type table below

Alarm Type

The alarm type has different meanings depending on the configured sensor type.

Bit	Name	Description
15-5	Reserved	Not used
4	Sensor Warning 2	Sensor Short circuit
3	Measurement Limit Low	The device minimum possible value has been reached. The measured value no longer changes as the sensor value continuous to decrease.
2	Measurement Limit High	The device maximum possible value has been reached. The measured value no longer changes as the sensor value continuous to increase.
1	Sensor Warning 1	Sensor break
0	General Error	This bit is always set in case of a measurement error. More details of the error can be shown in Bit 1...4

3.9.1 Example

Upstream packet: 0x0A 00 00 00 04

Decoding	
0A	Measurement Input Failure Alarm
00	Configuration ID = 0 (default configuration)
00	Reserved, always 0
0004	Measurement Limit High

4. Downstream Messages

4. Downstream Messages

Note: Devices including mioty[®] communication technology do not offer downstream message capabilities. Please configure your device using the Bluetooth[®] interface.

4.1 General Format

Downstream packets are usually sent by the IIoT platform to LoRaWAN[®] devices via the network in “store and forward” mode: they are scheduled in advance by the platform, stored in the LPWAN central server and transmitted just after an upstream packet has been received. The message is then interpreted by the device, which is expected to send a “configuration status” response (see chapter 3.6).

Downstream packets are identified using a transaction ID and can contain several commands.

The packets are formatted as follows:

Byte	Size (bytes)	Note
0	1	Transaction identifier (see chapter 2.5)
1	1	See command type table below
2, n+1	n (can be 0)	Command options (size depends on the command type)
n+2	1	Additional commands can be concatenated, one after another.
n+3...	m	

Downstream Command Types

Value (hex)	Upstream command types	Option size (bytes)
0x01	Reset to factory configuration	0
0x02	Set main configuration	13
0x04	Get main configuration	0
0x05	Reset battery indicator	1
0x20	Set process alarm configuration	20
0x40	Get process alarm configuration	1

4. Downstream Messages

The following diagram gives an indication how the device will react to a configuration change during runtime.

New configurations (in this case: change of transmission period)

Active phases exaggerated for clarity, typically they last for milliseconds to seconds while sleep phases last from a few minutes to several hours

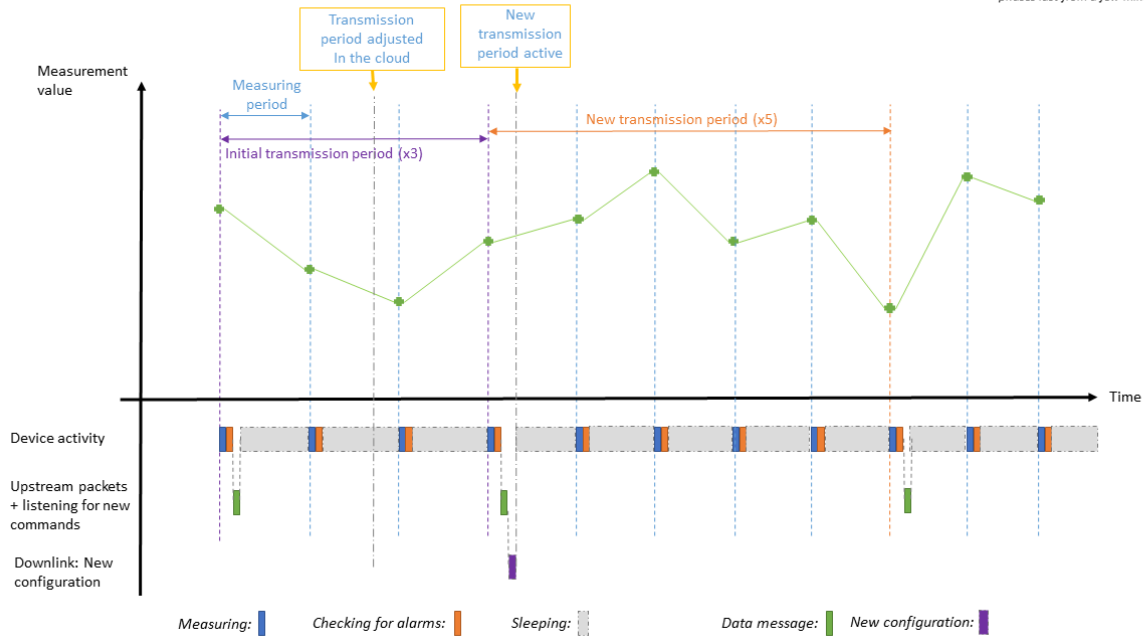

4.2 Reset to factory configuration command

This command will force the device to return to the factory configuration that is defined in the table below. It must not be sent with other commands in the same packet.

Byte	Size (bytes)	Value	Note
0	1	0x01	Reset to factory configuration command

4. Downstream Messages

4.3 Set main configuration

The main configuration of the device defines how often it wakes up to take a measurement, and what ratio of the measurements shall be transmitted to the platform as data messages.

Byte	Value	Note
0	0x02	Set main configuration command
1-4	Measurement period when no alarms are active	Period in seconds min. value = 2 s; max. value = 604800 s (7 days) Default: 60 s
5-6	Transmission multiplier when no alarms are active	Transmission period = measurement period * transmission multiplier max. transmission period 7 days, higher values are rejected Default multiplier: 30 (transmission every 1800s)
7-10	Measurement period when ≥ 1 alarm is active	Same unit, min./max., and default values as above
11-12	Transmission multiplier when ≥ 1 alarm is active	
13	0x00	Reserved, must always be transmitted with the given value

Measurement and transmission periods (different setting when at least one alarm is active or not)*

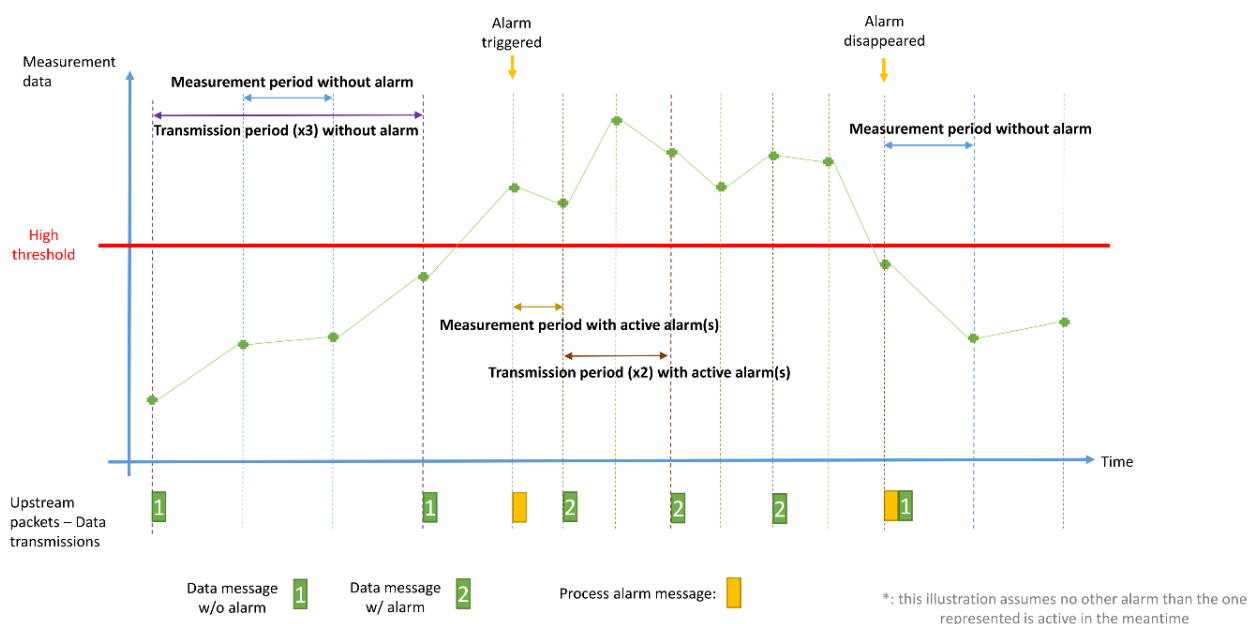

4. Downstream Messages

4.3.1 Example

Downstream packet: 0x07 02 000000B4 0005 0000003C 0003 00

Decoding	
07	Transaction ID: New Upstream messages will use Config ID 0x07
02	Set main configuration command
000000B4	Measurement period, no alarm = 180s = 3min
0005	Transmission multiplier, no alarm: 5 * 180s = 15min
0000003C	Measurement period, alarm active = 60s = 1min
0003	Transmission multiplier, alarm active: 3 * 1min = 3min
00	Reserved, always 0x00

4.4 Get main configuration

This command will trigger the device to send the current main configuration via LPWAN. It is especially useful in case the configuration was changed via the local interface. The local configuration change can be detected using the Config ID transmitted with each message.

Byte	Value	Note
0	0x04	Get main configuration command

4.5 Reset battery indicator

This command will reset the internal battery state of charge algorithm to a battery state of 100%. It should only be sent in case the device battery has been replaced.

Byte	Value	Note
0	0x05	Generic device command
1	0x00	Reset battery indicator command

4. Downstream Messages

4.6 Set process alarm configuration

This command can be used to activate and configure process alarms. All previous alarm configurations are replaced.

Attention: Please note that the total length of this configuration message is variable. Only the configuration values of the activated alarms must be included in the message.

Byte	Size (bytes)	Bit	Value	Note
0	1		0x20	Set process alarm command
1	1		0x00	Reserved, must always be 0x00
2	2		Dead band, common to all non-slope alarms	0...10,000 in increments of 0.01 % of span; common to all non-slope alarms
4	1	7	Alarm 1: Low threshold	For each alarm, the bit value means: 1: enabled 0: disabled
		6	Alarm 2: High threshold	
		5	Alarm 3: Falling slope	
		4	Alarm 4: Rising slope	
		3	Alarm 5: Low threshold with delay	
		2	Alarm 6: High threshold with delay	
		1-0	0	Reserved
5-20	2		Threshold value for alarm 1	Included only if the respective alarm is enabled (see Byte 7)
	2		Threshold value for alarm 2	
	2		Slope value for alarm 3	Thresholds in: 2,500...12,500 (0.01% of span)
	2		Slope value for alarm 4	
	2		Threshold value for alarm 5	Slope values in: 0...10,000 (0.01% of span/minute)
	2		Delay value for alarm 5 ⁵	
	2		Threshold value for alarm 6	
	2		Delay value for alarm 6 ⁵	

The slope value parameter is always positive but is interpreted differently for rising and falling slopes. For a rising slope, the alarm will be triggered if the value rises quicker than the value. For a falling slope, the alarm will be triggered if the value falls quicker than the value.

⁵ If set to zero, the alarm will act as a standard alarm without delay.

4. Downstream Messages

4.6.1 Example

Downstream packet: 0x01 20 00 0064 40 2000

Decoding	
01	Transaction ID: New Upstream messages will use Config ID 1
20	Set process alarm configuration
00	Reserved, always 0x00
0064	Dead-Band setting: $100 * 0,01\%$
40	High Threshold Alarm activated
2000	High Threshold Alarm at 56,92% of Span

4.7 Get process alarm configuration

This command will trigger the device to send the current process alarm configuration via LPWAN. It is especially useful in case the configuration was changed via the local interface. The local configuration change can be detected using the Config ID transmitted with each message.

Byte	Value	Note
0	0x40	Get process alarm configuration command
1	0x00	Reserved, must always be 0x00

5. Connectivity protocol: LoRaWAN®

5.1 Radio network integration

The model TRW is a “class A” battery-powered LoRaWAN® radio end-device using version 1.0.3 of the protocol and the regional radio parameters mentioned on the product label.

The TRW uses the OTAA “over-the-air activation” LoRaWAN® procedure. Each device is configured at the factory with a securely generated 128-bit random key. Knowledge of this key is required to enable a network to communicate with the device.

Only in case you have ordered the device to be used with your own network provider the following information are provided to you together with the device:

- LoRaWAN® DevEUI
- LoRaWAN® AppEUI
- 128-bit application key (AppKey)

Refer to the network service provider for further details on how to integrate your device. In case you are using a network server provided by WIKA, your device is already pre-attached.

5.2 Join procedure

At power on, the device will start a LoRaWAN® join sequence (1 try and 1 retry around 3 minutes later if the first try didn't succeed). If a network is in radio range and has knowledge about the AppKey the device will join the network.

In case of fail, the device goes to sleep for a random period, then launches a new join sequence. The sleep duration between 2 join sequences will be defined as:

- 10 to 15 min, the first time,
- 55 to 60 min, the second time,
- 10h00 to 10h05, the following times.

It keeps this last period infinitely, until join success or reboot.

5.3 LoRaWAN® ports

All upstream traffic generated by the TRW is sent on LoRaWAN® port 1.

The device will process all data downstream messages, no matter via which port they have been received. However, it is recommended to use port 1 for downstream communication.

5.4 Message Confirmation

The following upstream messages are sent as “confirmed” LoRaWAN® packets:

- Process-, Technical-, Device- and Measurement input failure alarms
- Device identification
- Configuration status
- Keep alive

If the network server does not confirm the reception of these messages, the TRW will try to retransmit them up to 3 times. Every two retries, the LoRaWAN® Spreading factor is incremented.

If three consecutive confirmed messages could not be transmitted, the device will perform a new network join process according to chapter 5.2.

6. Connectivity Protocol: mioty®

6. Connectivity Protocol: mioty®

6.1 Radio network integration

The TRW is available with the wireless protocol mioty®, offering a robust radio transmission for difficult receiving conditions. The mioty® version only integrates an uplink functionality, so all the device configurations must be done using the local Bluetooth® configuration interface. Each device is configured at the factory with a securely generated 128-bit random key. Knowledge of this key is required to enable a network to communicate with the device. Only in case you have ordered the device to be used with your own network provider the following information are provided to you together with the device:

- mioty® EUI
- mioty® Short Address
- 128-bit application key (AppKey)

Refer to the network service provider for further details on how to integrate your device. In case you are using a network server provided by WIKA, your device is already pre-attached.

6.2 Device behaviour

Because device information and configurations cannot be requested using downlink functionalities, additional message types and product functionalities have been implemented.

6.2.1 Identification Message

The identification message (Chapter 3.7) is repeated a second time after startup together with the second measurement value. Additionally, transmission of the identification message can be requested using the Bluetooth® interface or the corresponding WIKA App.

6.2.2 Configuration Messages

After device startup and in case the device configuration has been changed via the Bluetooth® interface the device is transmitting its configuration using additional message IDs. These IDs are not implemented for the LoRaWAN® version.

6. Connectivity Protocol: mioty®

Main Configuration Status Message

Byte	Value	Note
0	0x0B	Message ID for Device Main Configuration
1	Config ID	Current configuration ID
2-5	Measurement period when no alarms are active	Period in seconds
6-7	Transmission multiplier when no alarms are active	Transmission period = measurement period * transmission multiplier
8-11	Measurement period when ≥ 1 alarm is active	See above
12-13	Transmission multiplier when ≥ 1 alarm is active	
14	0x00	Reserved

Process Alarm Configuration Message

Byte	Bit	Value	Note
0		0x0C	Message ID for Process Alarm Configuration
1		Config ID	Current configuration ID
2		0x00	Reserved, always 0x00
3-4		Dead band, common to all non-slope alarms	0...10,000 in increments of 0.01 % of span; common to all non-slope alarms
5	7	Alarm 1: Low threshold	For each alarm, the bit value means: 1: enabled 0: disabled
	6	Alarm 2: High threshold	
	5	Alarm 3: Falling slope	
	4	Alarm 4: Rising slope	
	3	Alarm 5: Low threshold with delay	
	2	Alarm 6: High threshold with delay	
	1-0	0	
6-7		Threshold value for alarm 1	Included only if the respective alarm is enabled (see Byte 8)
8-9		Threshold value for alarm 2	
10-11		Slope value for alarm 3	Thresholds in: 2,500...12,500 (0.01% of span)
12-13		Slope value for alarm 4	
14-15		Threshold value for alarm 5	Slope values in: 0...10,000 (0.01% of span/minute)
16-17		Delay value for alarm 5	

6. Connectivity Protocol: mioty®

Byte	Bit	Value	Note
18-19		Threshold value for alarm 6	Delays in seconds
20-21		Delay value for alarm 6	

Channel Property Configuration Message

Byte	Value	Note
0	0x0D	Message ID for Channel property Configuration
1	Config ID	Current configuration ID
2	0x00	Reserved, always 0x00
3-4	Measurement offset	Signed value in 2s complement

LoRaWAN® is a trademark used under licence from LoRa Alliance®

mioty® is a registered trademark of the Fraunhofer IIS.

The Bluetooth® word mark and logos are registered trademarks owned by Bluetooth SIG, Inc. and any use of such marks by WIKA is under license. Other trademarks and trade names are those of their respective owners.

WIKA subsidiaries worldwide can be found online at www.wika.com.



Importer for UK

WIKAI Instruments Ltd

Unit 6 & 7 Goya Business Park

The Moor Road

Sevenoaks

Kent • United Kingdom

TN14 5GY



WIKAI Alexander Wiegand SE & Co. KG

Alexander-Wiegand-Straße 30

63911 Klingenberg • Germany

Tel. +49 9372 132-0

info@wika.de

www.wika.de

**Additional operating instructions
Zusatz-Betriebsanleitung
Mode d'emploi supplémentaire
Manual de instrucciones adicional
Instruções de operação adicionais**

Additional operating instructions for radio frequencies	EN
Zusatz-Betriebsanleitung für Funkfrequenzen	DE
Mode d'emploi supplémentaire pour les radiofréquences	FR
Manual de instrucciones adicional para radiofrecuencias	ES
Instruções de operação adicionais para frequências de rádio	PT



For instruments with LoRaWAN® and mioty®



Contents

Contents

EN

1. General information	3
2. Safety	6
3. Data transmission security	12
4. Information on wireless transmission	15
5. Approvals	16

Declarations of conformity can be found online at www.wika.com.

1. General information

Supplementary documentation:

- ▶ Please follow all the documentation included in the scope of delivery.



Before commissioning the instrument, the operating instructions of the relevant instrument must be noted.

EN

1. General information

- The instrument described in the operating instructions has been designed and manufactured using state-of-the-art technology. All components are subject to stringent quality and environmental criteria during production. Our management systems are certified in accordance with ISO 9001 and ISO 14001.
- These operating instructions contain important information on handling the instrument. Working safely requires that all safety instructions and work instructions are observed.
- Observe the relevant local accident prevention regulations and general safety regulations for the instrument's range of use.
- The operating instructions are part of the product and must be kept in the immediate vicinity of the instrument and readily accessible to skilled personnel at any time. Pass the operating instructions on to the next operator or owner of the instrument.
- Skilled personnel must have carefully read and understood the operating instructions prior to beginning any work.
- In case of a different interpretation of the translated and the English operating instructions, the English wording shall prevail.
- If available, the provided supplier documentation is also considered to be part of the product in addition to these operating instructions.
- The general terms and conditions contained in the sales documentation shall apply.
- Subject to technical modifications.
- Further information:
 - Internet address: www.wika.de / www.wika.com
 - Contact: [Tel.: +49 9372 132-0](tel:+4993721320)
info@wika.com

1. General information

Model	FCC Class	FCC ID	IC ID	Data sheet
NETRIS®1	B	Contains FCC IDs: VPYCMABZ	Contains IC IDs: 772C-CMABZ	AC 40.01
NETRIS®2	B	Contains FCC IDs: VPYCMABZ	Contains IC IDs: 772C-CMABZ	AC 40.02
NETRIS®3¹⁾	A	2BQILN3US915	34256-N3US915	AC 40.03
NETRIS®F	B	Contains FCC IDs: VPYCMABZ	Contains IC IDs: 772C-CMABZ	AC 40.10
PEW-1000	B	Contains FCC IDs: VPYCMABZ	Contains IC IDs: 772C-CMABZ	PE 87.23
PGW2x.100	-	-	-	PV 42.02
TRW	B	Contains FCC IDs: VPYCMABZ	Contains IC IDs: 772C-CMABZ	TE 63.04
GD-20-W	B	Contains FCC IDs: VPYCMABZ	Contains IC IDs: 772C-CMABZ	SP 60.78

1) This equipment is of the emission class A, intended for operation in industrial environments.

1. General information

1.1 Abbreviations, definitions

- Bullet
- ▶ Instruction
- 1. ... x. Follow the instruction step by step
- See ... cross-references
- FCC ID Unique identifier of the Federal Communications Commission (FCC)
- DevEUI/EUI Unique and one-off identifier for each instrument (ex-works) LoRa®/mioty®
- EUI64 64-bit extended unique identifier is a MAC address format standardised by the IEEE for the identification of network devices.
- IEEE Institute of Electrical and Electronics Engineers
- AES Advanced Encryption Standard
- CTR Counter
- CMAC Cipher-based Message Authentication Code
- NIST National Institute of Standards and Technology

1.2 Explanation of symbols and terms



Information

... points out useful tips, recommendations and information for efficient and trouble-free operation.

2. Safety

2. Safety

2.1 Intended use

EN IIoT solutions transmit measured values to a cloud via radio, depending on the instrument and specification in different industries, countries and regions. Due to the different countries and regions, there are differences in the individual radio authorisations, frequency bands and their transmission power. When selecting the country or region, it is assumed that the user has checked the selected frequency band for suitability with regard to the relevant regulations and approvals in order to prevent radio-frequency interference and infringements.

The instrument has been designed and engineered solely for the intended use described here, and may only be used accordingly.

The technical specifications of the respective instruments must be observed, see operating instructions of the respective instrument. It is assumed that the instrument is handled properly and within its technical specifications. Otherwise, the instrument must be taken out of service immediately and inspected by an authorised WIKA service engineer.

2.2 Improper use

Any use beyond or different to the intended use is considered as improper use, see the operating instructions of the individual instrument.

2. Safety

2.3 Labelling, safety markings (example)

The label is an example illustration. The positions can vary depending on the product and design.

The extended unique identifier (DevEUI with LoRaWAN® and “EUI” with mioty®) is a globally unique ID, which can identify the end device. It must not exist twice. This ID is specified in IEEE EUI64 format.

EN

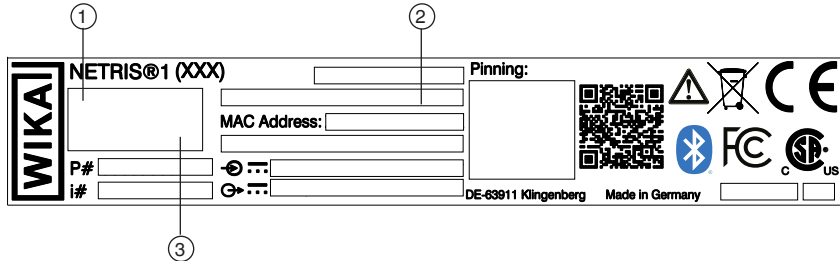

- ① Radio standards with specification of the “Regional Profile WAN”
- ② DevEUI for LoRaWAN® and “EUI” for mioty®
- ③ Country-specific approval markings such as FCC ID, IC ID, etc.

2.4 Requirements for wireless transmission



The use of the radio unit is subject to the provisions and regulations of the respective country. The module may only be used in the countries for which a country certification is available. Export to countries for which the product has no approval is not permitted.

2. Safety



With this version of the operating instructions, the instrument is approved for operation in the following countries:

EU countries

Belgium, Bulgaria, Denmark, Germany, Estonia, Finland, France, Greece, Ireland, Italy, Croatia, Latvia, Lithuania, Luxembourg, Malta, the Netherlands, Austria, Poland, Portugal, Romania, Sweden, Slovakia, Slovenia, Spain, Czech Republic, Hungary and Cyprus

EFTA countries

Iceland, Liechtenstein, Norway and Switzerland

Other countries

United Kingdom UK

Other countries available upon request. For further information on radio approvals, see www.wika.de or data sheet of the respective instrument.

Instruments with FCC/ISED marking are also permitted in the USA and Canada.

If a unique identifier (example: "Contains FCC ID: EXAMPLEID" or "IC ID:EXAMPLEID") is present on its product label, the instrument has a valid radio approval for the USA and Canada. The unique approval ID for each instrument, see chapter "[1. General information](#)".

The FCC logo stands for compliance with the EMC regulations of the USA.



If a country is not included in the list, information on the use of WIKA products should be obtained from the WIKA subsidiary.

Use in other countries is not permitted, see chapter "[5. Approvals](#)".

2. Safety

2.5 IC notice

IC warnings RSS-Gen & RSS-247 statement

This device complies with Industry Canada licence-exempt RSS standard(s).

Operation is subject to the following two conditions :

1. This device may not cause interference.
2. This device must accept any interference, including interference that may cause undesired operation of the device.

This device should be installed and operated with minimum distance 20 cm between the radiator and human body.

Attention

Radio Frequency Radiation Exposure :

This equipment complies with IC radiation exposure limits set forth for an uncontrolled environment and meets the IC radio frequency (RF) Exposure Guidelines.

Co-location

This transmitter must not be co-located or operated in conjunction with any other antenna or transmitter.

2.6 FCC notice

Information from the FCC (Federal Communications Commission)

FCC warning statement class A

The instrument has been tested and complies with the limits of a class A digital instrument in accordance with Part 15 of the FCC Rules. The limit values are designed with adequate protection against harmful interferences when operating the instrument in a commercial environment. The instrument generates or uses high-frequency energy and radiates this. Non-compliance with the instructions in this instruction manual can lead to damaging interference in the radio communication.

Operation of this equipment in a residential area is likely to cause harmful interference in which case the user will be required to correct the interference at his own expense.

EN

2. Safety

FCC warning statement class B

This equipment has been tested and found to comply with the limits for a class B digital device, pursuant to Part 15 of the FCC rules. These limits are designed to provide reasonable protection against harmful interference in a residential installation. This equipment generates, uses and can radiate radio frequency energy and, if not installed and used in accordance with the instructions, may cause harmful interference to radio communications. However, there is no guarantee that interference will not occur in a particular installation. If this equipment does cause harmful interference to radio or television reception, which can be determined by switching the equipment off and on, the user is encouraged to try to correct the interference by one or more of the following measures:

- Reorient or relocate the receiving antenna.
- Increase the separation between the equipment and receiver.
- Connect the equipment into an outlet on a circuit different from that to which the receiver is connected.
- Consult the dealer or an experienced radio/TV technician for help.

The manufacturer shall not be liable for claims of any type based on operation contrary to the intended use. This product is an FCC-approved instrument. Modifications to the instrument lead to the instrument immediately shutdown.

For your own safety

Shielded cables should be used for a composite interface. This is to ensure continued protection against radio frequency interference.

Caution

Changes or modifications not expressly approved by the party responsible for compliance could void the user's authority to operate the equipment. Shielded interface cable must be used in order to comply with the emission limits.

FCC notice

This device complies with part 15 of the FCC rules.

Operation is subject to the following two conditions:

1. This device may not cause harmful interference.
2. This device must accept any interference received, including interference that may cause undesired operation.

This device should be installed and operated with minimum distance 20 cm between the radiator and human body.

2. Safety

Caution Radio Frequency Radiation Exposure

This equipment complies with FCC radiation exposure limits set forth for an uncontrolled environment and meets the FCC radio frequency (RF) Exposure Guidelines.

Co-location

This transmitter must not be co-located or operated in conjunction with any other antenna or transmitter.

2.7 Anatel notice

Resolution 680:

This equipment cannot be protected against harmful interference and must not cause interference in duly authorised systems.

Resolution 715:

For further information, please visit the ANATEL website - www.anatel.gov.br

2.8 IFT notice

Operation of this equipment is subject to the following two conditions: (1) this equipment or instrument must not cause harmful interference, and (2) this equipment or instrument must accept any interference, including interference that may cause undesired operation.

3. Data transmission security

3. Data transmission security

As part of the join request, a mutual authentication between an end device and the network is established. This ensures that only real and authorised devices are connected to real and authentic networks.

WIKA applications are origin-authenticated, integrity-protected, replication-protected and encrypted. Combined with mutual authentication, this protection ensures that network traffic has not been altered, comes from a legitimate device, is not understood by wiretaps, and has not been intercepted and replayed by unauthorised third parties. In addition, end-to-end encryption protects the data of applications exchanged between end devices and application servers. These security mechanisms are based on the standardised AES cryptographic algorithms. These algorithms have been analysed by the cryptographic community for many years, are recognised by NIST (National Institute of Standards and Technology) and continue to be accepted as best security practice for sensor nodes and networks.

3.1 LoRaWAN®

LoRaWAN® security uses the cryptographic principle of AES cryptography in combination with several operating modes: CMAC2 for integrity protection and CTR3 for encryption. Each LoRaWAN® device is personalised with a unique 128-bit AES key (AppKey) and a globally unique identifier (EUI-64-based DevEUI), both used during the device authentication process.

→ Further details can be found in the official LoRaWAN® Security White Paper from the LoRa Alliance®, see <https://lora-alliance.org>.

3.2 mioty®

Each end point possesses its own cryptographic key, with which its communication is encrypted. The procedure used is the symmetric, block-wise Advanced Encryption Standard with 128-bit keys (AES128). To verify the integrity, a Cipher-based Message Authentication Code (CMAC) is used, which signs the content of the message using the secret key mentioned above.

Information on wireless transmission

The transmission of the measured values to an IIoT platform is carried out at a preset transmission interval. The measurement and transmission intervals, and also the alarm limits, for particular measured values can be configured over the IIoT platform.

3. Data transmission security

Connecting within an LPWAN

The instrument can be connected via a LoRaWAN® or mioty® gateway to an IIoT infrastructure. For this, the instrument is connected to a LoRaWAN® or mioty® gateway and the measured values are transferred to the IIoT infrastructure (e.g. platform, PC, mobile device, etc.) at freely configurable intervals.

For the IIoT connection, all relevant data for registration and commissioning, as well as an interface specification for further processing of the data, are provided, see “Special documentation for LPWAN® communication protocol” (depending on the device) on the WIKA website.

The deployment package includes the following registration information:

- DevEUI/EUI (64-bit end device, unique identifier)
- AppEUI (64-bit unique application identifier, with LoRaWAN®)
- AppKey (128-bit key)
- Interface specification (see “Special documentation for LPWAN® communication protocol” (depending on the device) on the WIKA website.



With a customer-specific integration, the payload integration must be carried out by the customer in accordance with the “Special documentation for LPWAN® communication specifications (depending on the device) on the WIKA website.

Further information at [Github.com/WIKA-Group](https://github.com/WIKA-Group).

3.3 Bluetooth® Low Energy

Bluetooth® Low Energy communicates in the licence-free 2.4 GHz ISM band and is a globally harmonised energy efficient radio standard.

Bluetooth® Low Energy uses 40 channels between 2.402 GHz and 2.480 GHz.

Encryption is performed using the AES-128 encryption algorithm in combination with distributed key replacement.

The instrument transmits the measured pressure and temperature value as an additional broadcast message on the advertising channels 37, 38 and 39, in addition to the instrument name and the battery charge status.

Further information and detailed configuration and command options are available via a point-to-point connection.

Pairing is established using a passkey entry method and requires the entry of a security code.



Pairing is established using a passkey entry method and requires the entry of a security code.

Instrument settings can only be accessed after pairing has been completed. The pairing key for each instrument is random. The initial pairing key can be found on the enclosed quick start guide.

3. Data transmission security



If the security code is entered incorrectly five times, the instrument is blocked for connection with this code. After disconnecting the voltage supply or removing the battery, five attempts are once again available. If this is not possible for technical reasons, e.g. because the sensor cannot be reached to open the case, contact technical support.

3.4 Contents of the QR code on the product label (example)



LW:D0:70B3D597B0000002:70B3D597B0004D71:02A30002:S1A01FZFCOJ6:PD1883F69EBE3:CC9B3

Content	Identifier	Example LoRaWAN® PEW-1000 (Lxx) (pictured)	Example mioty® PEW-1000 (Mxx)	Comment
Preface	-	LW	MI	Technology identifier
SchemalD	-	D0	D0	-
JoinEUI (64 bit)	-	70B3D597B0000002	-	JoinEUI = AppEUI
DevEUI (64 bit)	-	70B3D597B0004D71	-	-
ProfileID	-	02A30002	-	02A3 = VendorID WIKA; 0002 last 4 digits of the JoinEUI
EUI	-	-	70B3D597B0000025	mioty® EUI
SerNum	S	1A01FZFCOJ6	1A01N14MPIG	Alphanumeric WIKA serial number (11-digit)
Proprietary	P	PE526EA6D495E	PE526EA6D495E	BT MAC address: E5:26:EA:6D:49:5E
Checksum	C	C9B3	8F3E	-

4. Information on wireless transmission

4. Information on wireless transmission

4.1 LoRaWAN®

Frequency band	Frequency band marking	Transmission power	Countries/regions
868.1 ... 868.5 MHz	EU868	Max. 14 dBm	Europe
902 ... 928 MHz	US915	Max. 36 dBm	North America
915 ... 928 MHz	AU915	Max. 30 dBm	Australia
915 ... 928 MHz	AS923	Max. 16 dBm	Asia
470 ... 510 MHz	CN470	Max. 19.15 dBm	China
865 ... 868 MHz	IN865	Max. 30 dBm	India
920 ... 923 MHz	KR920	Max. 14 dBm	South Korea

4.2 mioty®

Frequency band	Frequency band marking	Transmission power	Countries/regions
868.1 ... 868.5 MHz	EU868	Max. 14 dBm	Europe
902 ... 928 MHz	US915	Max. 36 dBm	North America
470 ... 510 MHz	CN470	Max. 19.15 dBm	China
865 ... 868 MHz	IN865	Max. 30 dBm	India









Some frequency ranges are only available on request. For further information on radio approvals, see www.wika.com.

The radio frequency labelling differs from country to country.

5. Approvals

5. Approvals

Logo	Description	Region
	EU declaration of conformity RED - Radio Equipment Directive EN 300 220-1 and EN 300 220-2, harmonised frequency range 868 ... 870 Mhz is used; LoRaWAN® or mioty®, max. transmission power 14 dBm. The instrument may be used without restrictions in the EU and in the EFTA countries.	European Union
	Radio Law Japan Radio approval	Japan
	Federal Communications Commission (FCC) for US Radio approval → If there is a clear identifier (example: „FCC ID: EXAMPLEID“ or „IC: 12345-ABCDE“) on its product label, the instrument has a valid radio approval for the USA. The FCC logo stands for compliance with the EMC regulations of the USA.	USA
-	Innovation, Science and Economic Development (ISED) for Canada Radio approval → If the text "Contains IC: X8WBC805M" is on its product label, the instrument has a valid radio approval for Canada.	Canada
-	ICASA (Independent Communications Authority of South Africa) Radio certification	South Africa
	Radiocommunications Equipment Rules Radio approval Australia - ABN 49 004 465 936 New Zealand - company no. 400909	Australia and New Zealand
	IFT Instituto Federal de Telecomunicaciones Radio approval	Mexico
	Agência Nacional de Telecomunicações Radio approval	Brazil



Some approvals are only available on request. For further information on the radio approvals, see www.wika.com.

Inhalt

1. Allgemeines	18
2. Sicherheit	21
3. Datenübertragungssicherheit	27
4. Hinweise zur Funkübertragung	30
5. Zulassungen	31

Konformitätserklärungen online unter www.wika.de.

1. Allgemeines

Ergänzende Dokumentation:

- ▶ Bitte alle im Lieferumfang enthaltenen Dokumente beachten.



Vor der Inbetriebnahme des Geräts ist zusätzlich die Betriebsanleitung des jeweiligen Geräts zu beachten.

1. Allgemeines

- Das in der Betriebsanleitung beschriebene Gerät wird nach dem aktuellen Stand der Technik konstruiert und gefertigt. Alle Bauteile unterliegen während der Herstellung strengen Qualitäts- und Umweltkriterien. Unsere Managementsysteme sind nach ISO 9001 und ISO 14001 zertifiziert.
- Diese Betriebsanleitung gibt wichtige Hinweise zum Umgang mit dem Gerät. Voraussetzung für sicheres Arbeiten ist die Einhaltung aller angegebenen Sicherheitshinweise und Handlungsanweisungen.
- Die für den Einsatzbereich des Geräts geltenden örtlichen Unfallverhütungsvorschriften und allgemeinen Sicherheitsbestimmungen einhalten.
- Die Betriebsanleitung ist Produktbestandteil und muss in unmittelbarer Nähe des Geräts für das Fachpersonal jederzeit zugänglich aufbewahrt werden. Betriebsanleitung an nachfolgende Bediener oder Besitzer des Geräts weitergeben.
- Das Fachpersonal muss die Betriebsanleitung vor Beginn aller Arbeiten sorgfältig durchgelesen und verstanden haben.
- Bei unterschiedlicher Auslegung der übersetzten und der englischen Betriebsanleitung ist der englische Wortlaut maßgebend.
- Falls vorhanden, gilt neben dieser Betriebsanleitung auch die mitgelieferte Zuliefererdokumentation als Produktbestandteil.
- Es gelten die allgemeinen Geschäftsbedingungen in den Verkaufsunterlagen.
- Technische Änderungen vorbehalten.

■ Weitere Informationen:

- Internet adresse:

www.wika.de / www.wika.com

- Kontakt:

Tel.: +49 9372 132-0

info@wika.de

1. Allgemeines

Typ	FCC Klasse	FCC ID	IC ID	Datenblatt
NETRIS®1	B	Enthält FCC IDs: VPYCMABZ	Enthält IC IDs: 772C-CMABZ	AC 40.01
NETRIS®2	B	Enthält FCC IDs: VPYCMABZ	Enthält IC IDs: 772C-CMABZ	AC 40.02
NETRIS®3 ¹⁾	A	2BQILN3US915	34256-N3US915	AC 40.03
NETRIS®F	B	Enthält FCC IDs: VPYCMABZ	Enthält IC IDs: 772C-CMABZ	AC 40.10
PEW-1000	B	Enthält FCC IDs: VPYCMABZ	Enthält IC IDs: 772C-CMABZ	PE 87.23
PGW2x.100	-	-	-	PV 42.02
TRW	B	Enthält FCC IDs: VPYCMABZ	Enthält IC IDs: 772C-CMABZ	TE 63.04
GD-20-W	B	Enthält FCC IDs: VPYCMABZ	Enthält IC IDs: 772C-CMABZ	SP 60.78

1) Dieses Gerät entspricht der Emissionsklasse A und ist für den Betrieb in industrieller Umgebung vorgesehen.

DE

1. Allgemeines

1.1 Abkürzungen, Definitionen

■	Aufzählungssymbol
▶	Handlungsanweisung
1. ... x.	Handlungsanweisung Schritt für Schritt durchführen
→	Siehe ... Querverweise
FCC ID	Eindeutige Kennung der Federal Communications Commission (FCC)
DevEUI/EUI	Eindeutige und einmalige Kennung eines jeden Geräts (ab Werk) LoRa®/mioty®
EUI64	64-Bit Extended Unique Identifier bezeichnet man ein vom IEEE standardisiertes MAC-Adressformat zur Identifikation von Netzwerkgeräten.
IEEE	Institute of Electrical and Electronics Engineers
AES	Advanced Encryption Standard
CTR	Counter
CMAC	Cipher-based Message Authentication Code
NIST	National Institute of Standards and Technology

1.2 Symbol- und Begriffserklärung



Information

... hebt nützliche Tipps und Empfehlungen sowie Informationen für einen effizienten und störungsfreien Betrieb hervor.

2. Sicherheit

2. Sicherheit

2.1 Bestimmungsgemäße Verwendung

Die IIoT-Lösungen übertragen per Funk Messwerte in eine Cloud, je nach Gerät und Spezifikation in verschiedenen Industrien und Ländern bzw. Regionen. Aufgrund der verschiedenen Länder bzw. Regionen ergeben sich Unterschiede in den einzelnen Funkzulassungen, Frequenzbändern und deren Übertragungsleistung. Bei der Wahl des Lands bzw. der Region wird vorausgesetzt, dass der Nutzer das ausgewählte Frequenzband auf entsprechende Eignung im Bezug auf die jeweiligen Vorschriften und Zulassungen geprüft hat, um Funkstörung und Verstöße zu verhindern.

Das Gerät ist ausschließlich für den hier beschriebenen bestimmungsgemäßen Verwendungszweck konzipiert und konstruiert und darf nur dementsprechend verwendet werden.

Die technischen Spezifikationen der jeweiligen Geräte sind einzuhalten, siehe Betriebsanleitung des jeweiligen Geräts. Eine sachgemäße Handhabung und das Betreiben des Geräts innerhalb der technischen Spezifikationen wird vorausgesetzt. Andernfalls ist eine sofortige Stilllegung und Überprüfung durch einen autorisierten WIKA-Servicemitarbeiter erforderlich.

2.2 Fehlgebrauch

Jede über die bestimmungsgemäße Verwendung hinausgehende oder andersartige Benutzung gilt als Fehlgebrauch, siehe Betriebsanleitung des jeweiligen Geräts.

DE

2. Sicherheit

2.3 Beschilderung, Sicherheitskennzeichnungen (Beispiel)

Das Schild ist eine exemplarische Darstellung. Die Positionen können je nach Produkt und Bauform variieren. Der Extended Unique Identifier (DevEUI bei LoRaWAN® und „EUI“ bei mioty®) ist eine global eindeutige ID, die das Endgerät identifizieren kann. Sie darf nicht zweimal vorhanden sein. Diese ID wird im IEEE EUI64 Format angegeben.

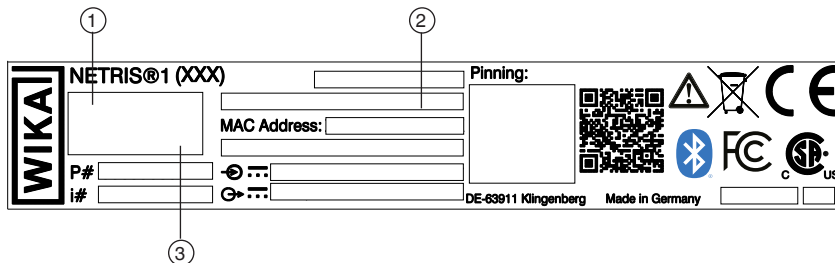

- ① Funkstandards mit Angabe des „Regional Profile WAN“
- ② DevEUI bei LoRaWAN® und „EUI“ bei mioty®
- ③ Länderspezifische Zulassungskennzeichnungen wie FCC-ID, IC-ID, etc.

2. Sicherheit

2.4 Anforderungen für Funkübertragung



Die Verwendung der Funkeinheit unterliegt den Regelungen und Bestimmungen des jeweiligen Einsatzlands. Das Modul darf nur in den Ländern eingesetzt werden, für die eine Länderzertifizierung vorliegt.

Die Ausfuhr in Länder, für die das Produkt keine Zulassung besitzt, ist nicht gestattet.



Mit dieser Version der Betriebsanleitung ist das Gerät in den folgenden Ländern zum Betrieb zugelassen:

EU-Länder

Belgien, Bulgarien, Dänemark, Deutschland, Estland, Finnland, Frankreich, Griechenland, Irland, Italien, Kroatien, Lettland, Litauen, Luxemburg, Malta, die Niederlande, Österreich, Polen, Portugal, Rumänien, Schweden, die Slowakei, Slowenien, Spanien, die Tschechische Republik, Ungarn und Zypern

EFTA-Länder

Island, Liechtenstein, Norwegen und Schweiz

Weitere Länder

Vereinigtes Königreich UK

Weitere Länder auf Anfrage verfügbar. Weitere ausführliche Informationen zu den Funkzulassungen siehe www.wika.de oder Datenblatt des jeweiligen Geräts.

Geräte mit FCC/ISED-Kennzeichnung sind zusätzlich für USA und Kanada zugelassen.

Wenn auf dem Typenschild eine eindeutige Kennung (Beispiel: „Contains FCC ID: EXAMPLEID“ oder „IC ID:EXAMPLEID“) vorhanden ist, verfügt das Gerät über eine gültige Funkzulassung für die USA und Kanada. Für die eindeutige Zulassungs-ID je Gerät, siehe „[1_Allgemeines](#)“.

Das FCC-Logo steht für die Einhaltung der EMV-Regularien der USA.



Wenn ein Land nicht in der Liste enthalten ist, sollten Informationen zur Verwendung von WIKA-Produkten bei der WIKA-Niederlassung eingeholt werden.

Eine Nutzung in anderen Ländern ist nicht gestattet, siehe Kapitel [5„Zulassungen“](#).

2. Sicherheit

2.5 IC-Hinweise

Warnhinweise RSS-Gen & Erklärung RSS-247

Dieses Gerät erfüllt die Anforderungen der Radio Standards Specification (RSS) von Industry Canada an lizenzfreie Funkgeräte.

Der Betrieb unterliegt den beiden folgenden Bedingungen:

1. Das Gerät darf keine Störungen erzeugen.
2. Der Benutzer des Geräts muss alle auftretenden Funkstörungen vertragen, einschließlich Störungen, die einen unerwünschten Betrieb verursachen können.

Dieses Gerät sollte mit einem Mindestabstand von 20 cm zwischen dem Heizkörper und dem menschlichen Körper installiert und betrieben werden.

Achtung

Strahlenbelastung bei Funkfrequenzen:

Dieses Gerät entspricht den IC-Grenzwerten für Strahlenbelastung in einer unkontrollierten Umgebung und erfüllt die Richtlinien hinsichtlich der Belastung bei Funkfrequenzen (RF) gemäß IC.

Co-Location

Dieser Transmitter darf nicht in Verbindung mit einer anderen Antenne oder einem anderen Transmitter aufgestellt oder betrieben werden, unabhängig von dessen Typ.

2.6 FCC-Hinweise

Informationen von der FCC (Federal Communications Commission)

FCC-Warnhinweis, Klasse A

Dieses Gerät wurde einer Überprüfung unterzogen und erfüllt nachweislich die Grenzwerte für ein Digitalgerät der Klasse A gemäß Teil 15 der FCC-Vorschriften. Die Grenzwerte sollen einen angemessenen Schutz vor schädlichen Störungen bieten, wenn die Geräte im gewerblichen Rahmen betrieben werden. Dieses Gerät erzeugt und benutzt hochfrequente Energien und kann diese abstrahlen. Wenn es nicht in Übereinstimmung mit den Handlungsanweisungen in dieser Bedienungsanleitung installiert und verwendet wird, kann es den Rundfunkempfang erheblich beeinträchtigen.

Bei Betrieb dieses Geräts in einem Wohngebiet ist mit Störungen zu rechnen, bei deren Vorliegen der Bediener diese auf eigene Kosten beheben muss.

2. Sicherheit

FCC-Warnhinweis, Klasse B

Dieses Gerät wurde einer Überprüfung unterzogen und erfüllt nachweislich die Grenzwerte für ein Digitalgerät der Klasse B nach Teil 15 der FCC-Vorschriften. Diese Grenzwerte sollen einen angemessenen Schutz gegen Störungen bei Installation in einem Wohngebiet garantieren. Dieses Gerät erzeugt, nutzt und strahlt Energie in Form von Funkfrequenzen ab, die bei Installation und Verwendung unter Nichtbeachtung der Anleitung zu schädlichen Störungen in der Funkkommunikation führen können. Es gibt jedoch keine Garantie dafür, dass es bei bestimmten Installationen nicht doch zu Störungen kommt. Wenn dieses Gerät Störungen des Rundfunk- und Fernsehempfangs verursacht, was durch Aus- und Einschalten des Geräts festgestellt werden kann, sollte der Benutzer versuchen, die Störung durch eine oder mehrere der folgenden Maßnahmen zu beheben:

- Die Empfängerantenne an einer anderen Stelle platzieren bzw. diese neu ausrichten.
- Den Abstand zwischen dem Gerät und dem Empfänger vergrößern.
- Das Gerät an einen Stromkreis anschließen, den der Empfänger nicht benutzt.
- An den Händler oder einen erfahrenen Rundfunk-/TV-Techniker wenden.

Ansprüche jeglicher Art aufgrund von nicht bestimmungsgemäßer Verwendung sind ausgeschlossen.

Bei diesem Produkt handelt es sich um ein FCC-zugelassenes Gerät. Umbauten am Gerät führen zu einem sofortigen Stillsetzen des Geräts.

Zur eigenen Sicherheit

Für eine Composite-Schnittstelle sollten geschirmte Kabel verwendet werden. Damit soll ein kontinuierlicher Schutz vor Funkstörungen gewährleistet werden.

Vorsicht

Veränderungen oder Modifikationen, die nicht ausdrücklich durch die für die Konformität zuständige Stelle genehmigt sind, könnten die Berechtigung des Benutzers zum Betreiben des Geräts ungültig machen. Um die Emissionsgrenzen einhalten zu können, müssen geschirmte Kabel verwendet werden.

FCC-Hinweis

Dieses Gerät erfüllt Teil 15 der FCC-Vorschriften.

Der Betrieb unterliegt den beiden folgenden Bedingungen:

1. Dieses Gerät darf keine schädlichen Störungen verursachen.
2. Dieses Gerät muss alle empfangenen Störungen vertragen, einschließlich Störungen, die einen unerwünschten Betrieb verursachen können.

2. Sicherheit

Dieses Gerät sollte mit einem Mindestabstand von 20 cm zwischen dem Heizkörper und dem menschlichen Körper installiert und betrieben werden.

Vorsicht: Strahlenbelastung bei Funkfrequenzen

Dieses Gerät entspricht den FCC-Grenzwerten für Strahlenbelastung in einer unkontrollierten Umgebung und erfüllt die Richtlinien hinsichtlich der Belastung bei Funkfrequenzen gemäß FCC.

DE

Co-Location

Dieser Transmitter darf nicht in Verbindung mit einer anderen Antenne oder einem anderen Transmitter aufgestellt oder betrieben werden

5.1 Anatel Hinweise

Resolution 680:

This equipment cannot be protected against harmful interference and must not cause interference in duly authorised systems.

Resolution 715:

For further information, please visit the ANATEL website - www.anatel.gov.br

5.2 IFT Hinweise

Der Betrieb dieses Betriebsmittels unterliegt den beiden folgenden Bedingungen: (1) Dieses Betriebsmittel oder Gerät darf keine schädlichen Störungen verursachen und (2) dieses Betriebsmittel oder Gerät muss alle Störungen vertragen, einschließlich Störungen, die einen unerwünschten Betrieb verursachen können.

3. Datenübertragungssicherheit

3. Datenübertragungssicherheit

Als Teil des Join-Request ist eine gegenseitige Authentifizierung zwischen einem Endgerät und dem Netzwerk eingerichtet. Dadurch wird sichergestellt, dass nur reale und autorisierte Geräte an reale und authentische Netzwerke angeschlossen werden.

WIKA-Anwendungen sind ursprungsauthentifiziert, integritätsgeschützt, wiederholungsgeschützt und verschlüsselt. Kombiniert mit der gegenseitigen Authentifizierung stellt dieser Schutz sicher, dass der Netzwerkverkehr nicht verändert wurde, von einem legitimen Gerät stammt, für Abhörgeräte nicht verständlich ist und nicht von unbefugten Dritten abgefangen und wiedergegeben wurde. Zusätzlich schützt eine Ende-zu-Ende-Verschlüsselung die Daten von Anwendungen, die zwischen den Endgeräten und den Anwendungsservern ausgetauscht werden. Die genannten Sicherheitsmechanismen beruhen auf den standardisierten kryptografischem AES-Algorithmen. Diese Algorithmen werden seit vielen Jahren von der kryptografischen Gemeinschaft analysiert, sind vom NIST (National Institute of Standards and Technology) anerkannt und werden weiterhin als beste Sicherheitspraxis für Sensorknoten und Netzwerke angenommen.

3.1 LoRaWAN®

Die LoRaWAN®-Sicherheit verwendet das kryptografische Prinzip der AES-Kryptografie in Kombination mit mehreren Betriebsarten: CMAC2 für den Integritätsschutz und CTR3 für die Verschlüsselung. Jedes LoRaWAN®-Gerät wird mit einem einzigartigen 128-Bit-AES-Schlüssel (AppKey) und einer weltweit einzigartigen Kennung (EUI-64-basiertes DevEUI) personalisiert, die beide während des Geräteauthentifizierungsprozesses verwendet werden.

→ Weitere Details können im offiziellen LoRaWAN® Security White Paper von der LoRa Alliance® nachgelesen werden, siehe <https://lora-alliance.org>.

3.2 mioty®

Jeder Endpunkt verfügt über einen eigenen kryptografischen Schlüssel, mit dem seine Kommunikation verschlüsselt wird. Das verwendete Verfahren ist der symmetrische, blockweise Advanced Encryption Standard mit 128-Bit-Schlüsseln (AES-128). Zur Überprüfung der Integrität wird ein Cipher-based Message Authentication Code (CMAC) verwendet, der den Inhalt der Nachricht mit dem oben genannten geheimen Schlüssel signiert.

Hinweise zur Funkübertragung

Die Übertragung der gemessenen Werte in eine IIoT-Plattform erfolgt in einem voreingestellten Übertragungsintervall. Die Mess- und Übertragungsintervalle sowie die Alarmgrenzen für besondere Messwerte lassen sich über die IIoT-Plattform konfigurieren.

DE

3. Datenübertragungssicherheit

Anbindung in ein LPWAN

Das Gerät kann über LoRaWAN®- oder mioty®-Gateway an eine IIoT-Infrastruktur angebunden werden. Hierfür wird das Gerät mit einem LoRaWAN® oder mioty® Gateway verbunden und die Messwerte in frei konfigurierbaren Zeitabständen in die IIoT-Infrastruktur (z. B. Plattform, PC, mobiles Endgerät etc.) übertragen.

Für die IIoT-Anbindung werden alle relevanten Daten zur Registrierung und Inbetriebnahme, sowie eine Schnittstellenspezifikation für die Weiterverarbeitung der Daten zur Verfügung gestellt, siehe „Special documentation for LPWAN® communication specifications“ (je nach Gerät) auf der WIKA-Webseite.

Das Bereitstellungspaket beinhaltet folgende Registrierungsdaten:

- DevEUI/EUI (64-Bit-Endgerät, eindeutige Kennung)
- AppEUI (64-Bit Unique Application Identifier, bei LoRaWAN®)
- AppKey (128-Bit-Schlüssel)
- Schnittstellenspezifikation, siehe „Special documentation for LPWAN® communication specifications“ (je nach Gerät) auf der WIKA-Webseite.



Bei einer kundenspezifischen Anbindung muss die Payload-Integration entsprechend „Special documentation for LPWAN® communication specifications“ (je nach Gerät) auf der WIKA-Webseite kundenseitig erfolgen.

Weitere Informationen auf [Github.com/WIKA-Group](https://github.com/WIKA-Group).

3.3 Bluetooth® Low Energy

Bluetooth® Low Energy kommuniziert im lizenzfreien 2,4 GHz ISM-Band und ist ein global einheitlicher energieeffizienter Funkstandard. Bluetooth® Low Energy verwendet 40 Kanäle zwischen 2,402 GHz und 2,480 GHz. Die Verschlüsselung erfolgt mithilfe des AES-128-Encryption-Algorithmus in Kombination mit einer verteilten Schlüsselauswechslung. Das Gerät überträgt als Broadcast Message auf den Advertising-Kanälen 37, 38 und 39 neben dem Gerätenamen und dem Batterieladestatus zusätzlich den Druck- und Temperaturmesswert. Über eine Punkt-zu-Punkt-Verbindung stehen weitere Informationen und ausführliche Konfigurations- und Befehlsmöglichkeiten zur Verfügung.

Das Pairing wird über eine Passkey-Entry-Methode hergestellt und verlangt die Eingabe eines Sicherheitscodes.



Das Pairing wird über eine Passkey-Entry-Methode hergestellt und verlangt die Eingabe eines Sicherheitscodes. Erst nach erfolgreichem Pairing kann auf Geräteeinstellungen zugegriffen werden. Der Pairing Key ist für jedes Gerät zufällig. Der initiale Pairing Key ist auf dem beiliegenden Quick-Start-Guide zu finden.

3. Datenübertragungssicherheit



Wird der Sicherheitscode fünfmal falsch eingegeben, ist das Gerät für die Verbindung mit diesem Code gesperrt. Nach einem Trennen der Spannungsversorgung bzw. dem Entnehmen der Batterie sind wieder fünf Versuche verfügbar. Sollte das aus technischen Gründen nicht möglich sein, da z. B. der Sensor zum Öffnen des Gehäuses nicht erreichbar ist, den Technischen Support kontaktieren.

3.4 Inhalt des QR-Codes auf dem Typenschild (Beispiel)



LW:D0:70B3D597B0000002:70B3D597B0004D71:02A30002:S1A01FZFCOJ6:PD1883F69EBE3:CC9B3

Inhalt	Kennung	Beispiel LoRaWAN® PEW-1000 (Lxx) (abgebildet)	Beispiel mioty® PEW-1000 (Mxx)	Kommentar
Preface	-	LW	MI	Technologiekennung
SchemalD	-	D0	D0	-
JoinEUI (64 Bit)	-	70B3D597B0000002	-	JoinEUI = AppEUI
DevEUI (64 Bit)	-	70B3D597B0004D71	-	-
ProfileID	-	02A30002	-	02A3 = VendorID WIKA; 0002 letzte 4 Stellen der JoinEUI
EUI	-	-	70B3D597B0000025	mioty® EUI
SerNum	S	1A01FZFCOJ6	1A01N14MPIG	Alphanumerische WIKA-Seriennummer (11-stellig)
Proprietary	P	PE526EA6D495E	PE526EA6D495E	BT MAC-Adresse: E5:26:EA:6D:49:5E
CheckSum	C	C9B3	8F3E	-

3. Datenübertragungssicherheit

4. Hinweise zur Funkübertragung

4.1 LoRaWAN®

Frequenzband	Frequenzband-Kennzeichnung	Übertragungsleistung	Länder/Regionen
868,1 ... 868,5 MHz	EU868	Max. 14 dBm	Europa
902 ... 928 MHz	US915	Max. 36 dBm	Nordamerika
915 ... 928 MHz	AU915	Max. 30 dBm	Australien
915 ... 928 MHz	AS923	Max. 16 dBm	Asien
470 ... 510 MHz	CN470	Max. 19,15 dBm	China
865 ... 868 MHz	IN865	Max. 30 dBm	Indien
920 ... 923 MHz	KR920	Max. 14 dBm	Südkorea

4.2 mioty®

Frequenzband	Frequenzband-Kennzeichnung	Übertragungsleistung	Länder/Regionen
868,1 ... 868,5 MHz	EU868	Max. 14 dBm	Europa
902 ... 928 MHz	US915	Max. 36 dBm	Nordamerika
470 ... 510 MHz	CN470	Max. 19,15 dBm	China
865 ... 868 MHz	IN865	Max. 30 dBm	Indien



Einige Frequenzbereiche nur auf Anfrage verfügbar. Weitere ausführliche Informationen zu den Funkzulassungen siehe www.wika.de.
Die Funkfrequenz-Kennzeichnung wird von Land zu Land unterschiedlich genannt.

5. Zulassungen

5. Zulassungen

Logo	Beschreibung	Region
	EU-Konformitätserklärung RED-Funkanlagenrichtlinie EN 300 220-1 und EN 300 220-2, harmonisierter Frequenzbereich 868 ... 870 Mhz wird verwendet; LoRaWAN® oder mioty®, max. Übertragungsleistung 14 dBm. Das Gerät darf ohne Einschränkungen in der EU sowie in den Ländern der EFTA eingesetzt werden.	Europäische Union
	Radio Law Japan Funkzulassung	Japan
	Federal Communications Commission (FCC) for US Funkzulassung → Wenn auf dem Typenschild eine eindeutige Kennung (Beispiel: „FCC-ID: EXAMPLEID) vorhanden ist, hat das Gerät eine gültige Funkzulassung für die USA. → Das FCC-Logo steht für die Einhaltung der EMV-Regulieren der USA.	USA
-	Innovation, Science, and Economic Development (ISED) for Canada Funkzulassung → Befindet sich der Text „Contains IC: X8WBC805M“ auf ihrem Typenschild, besitzt das Gerät eine gültige Funkzulassung für Kanada.	Kanada
-	ICASA (Independent Communications Authority of South Africa) Funkzertifizierung	Südafrika
	Radiocommunications Equipment Rules Funkzulassung Australien - ABN 49 004 465 936 Neuseeland - Unternehmens-Nr. 400909	Australien und Neuseeland
	IFT Instituto Federal de Telecomunicaciones Radio approval	Mexico
	Agência Nacional de Telecomunicações Funkzulassung	Brasilien

DE

5. Zulassungen



Einige Zulassungen nur auf Anfrage verfügbar. Weitere ausführliche Informationen zu den Funkzulassungen siehe www.wika.de.

DE

Sommaire

1. Généralités	34
2. Sécurité	37
3. Sécurité de la transmission des données	43
4. Informations sur la transmission sans fil	46
5. Agréments	47

Déclarations de conformité disponibles sur www.wika.fr.

1. Généralités

Documentation supplémentaire :

- ▶ Prière de se conformer à toute la documentation incluse dans le détail de la livraison.



Avant la mise en service de l'instrument, le mode d'emploi de l'instrument concerné doit être respecté.

FR

1. Généralités

- L'instrument décrit dans le mode d'emploi est conçu et fabriqué selon les dernières technologies. Tous les composants sont soumis à des critères de qualité et de respect de l'environnement stricts durant la fabrication. Nos systèmes de management sont certifiés selon les normes ISO 9001 et ISO 14001.
- Ce mode d'emploi donne des indications importantes concernant l'utilisation de l'instrument. Il est possible de travailler en toute sécurité avec ce produit en respectant toutes les consignes de sécurité et d'utilisation.
- Respecter les prescriptions locales de prévention contre les accidents et les prescriptions générales de sécurité en vigueur pour le domaine d'application de l'instrument.
- Le mode d'emploi fait partie de l'instrument ; il doit être conservé à proximité immédiate de celui-ci et accessible à tout moment pour le personnel qualifié. Confier le mode d'emploi à l'utilisateur ou au propriétaire ultérieur de l'instrument.
- Le personnel qualifié doit, avant de commencer toute opération, avoir lu soigneusement et compris le mode d'emploi.
- En cas d'interprétation différente de la version traduite et de la version anglaise du mode d'emploi, c'est la version anglaise qui prévaut.
- Le cas échéant, la documentation fournie par le fournisseur est également considérée comme faisant partie du produit, en plus du présent mode d'emploi.
- Les conditions générales de vente mentionnées dans les documents de vente s'appliquent.
- Sous réserve de modifications techniques.

- Pour obtenir d'autres informations :
 - Site Internet : www.wika.fr / www.wika.com
 - Contact : Tél. : +49 9372 132-0
info@wika.fr

1. Généralités

Type	FCC Classe	FCC ID	IC ID	Fiche technique
NETRIS®1	B	Contient FCC IDs: VPYCMABZ	Contient IC IDs: 772C-CMABZ	AC 40.01
NETRIS®2	B	Contient FCC IDs: VPYCMABZ	Contient IC IDs: 772C-CMABZ	AC 40.02
NETRIS®3 ¹⁾	A	2BQILN3US915	34256-N3US915	AC 40.03
NETRIS®F	B	Contient FCC IDs: VPYCMABZ	Contient IC IDs: 772C-CMABZ	AC 40.10
PEW-1000	B	Contient FCC IDs: VPYCMABZ	Contient IC IDs: 772C-CMABZ	PE 87.23
PGW2x.100	-	-	-	PV 42.02
TRW	B	Contient FCC IDs: VPYCMABZ	Contient IC IDs: 772C-CMABZ	TE 63.04
GD-20-W	B	Contient FCC IDs: VPYCMABZ	Contient IC IDs: 772C-CMABZ	SP 60,78

1) Cet équipement appartient à la classe d'émissions A et est prévu pour être utilisé dans des environnements industriels.

FR

1. Généralités

1.1 Abréviations, définitions

■	Puce
▶	Instruction
1. ... x.	Suivre les instructions étape par étape
→	Voir ... renvois
FCC ID	Identifiant unique de la FCC (Federal Communications Commission)
DevEUI/EUI	Identifiant unique et ponctuel pour chaque instrument (ex-works) LoRa® / mioty®
EUI64	L'identifiant unique étendu de 64 bits est un format d'adresse MAC normalisé par l'IEEE pour l'identification des périphériques de réseau.
IEEE	Institute of Electrical and Electronics Engineers
AES	Advanced Encryption Standard
CTR	Counter
CMAC	Cipher-based Message Authentication Code
NIST	National Institute of Standards and Technology

1.2 Explication des symboles et termes



Information

... met en exergue les conseils et recommandations utiles de même que les informations permettant d'assurer un fonctionnement efficace et normal.

2. Sécurité

2. Sécurité

2.1 Utilisation conforme à l'usage prévu

Les solutions IIoT transmettent les valeurs mesurées à un cloud par radio, en fonction de l'instrument et de la spécification dans différents secteurs, pays et régions. En raison de la diversité des pays et des régions, il existe des différences dans les autorisations radio individuelles, les bandes de fréquences et leur puissance d'émission. Lorsque l'utilisateur sélectionne un pays ou une région, il est censé avoir vérifié l'adéquation de la bande de fréquence sélectionnée au regard des réglementations et homologations applicables afin d'éviter les interférences et les infractions en matière de radiofréquences.

L'instrument est conçu et construit exclusivement pour une utilisation conforme à l'usage prévu décrit ici et ne doit être utilisé qu'en conséquence.

Les spécifications techniques des instruments respectifs doivent être respectées, voir le mode d'emploi de l'instrument concerné. Il est présumé que l'instrument est manipulé correctement et dans le respect de ses spécifications techniques. Dans le cas contraire, l'instrument doit être immédiatement mis hors service et inspecté par un technicien WIKA agréé.

2.2 Utilisation inappropriée

Toute utilisation différente ou au-delà de l'utilisation prévue est considérée comme inappropriée. Voir le mode d'emploi de chaque instrument.

FR

2. Sécurité

2.3 Etiquetage, marquages de sécurité (exemple)

L'étiquette est proposée à titre d'exemple. Les positions peuvent varier en fonction du produit et de la conception. L'identifiant unique étendu (DevEUI avec LoRaWAN® et "EUI" avec mioty®) est un identifiant unique au niveau mondial, qui permet d'identifier le dispositif terminal. Il ne doit pas exister en double. Cet identifiant est spécifié au format IEEE EUI64.

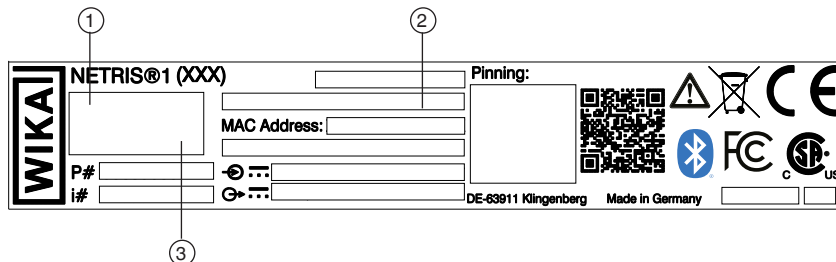

- ① Normes radio avec spécification du "WAN de profil régional"
- ② DevEUI pour LoRaWAN® et "EUI" pour mioty®
- ③ Marques d'homologation nationales telles que FCC ID, IC ID, etc.

2.4 Exigences en matière de transmission sans fil



L'utilisation de l'unité radio est soumise aux conditions et réglementations de chaque pays. Le module peut être utilisé uniquement dans les pays pour lesquels une certification nationale est disponible. Il n'est pas permis d'exporter vers des pays où le produit n'est pas homologué.



Avec cette version du mode d'emploi, l'instrument est homologué pour une utilisation dans les pays suivants :

Pays de l'UE

Belgique, Bulgarie, Danemark, Allemagne, Estonie, Finlande, France, Grèce, Irlande, Italie, Croatie, Lettonie, Lituanie, Luxembourg, Malte, Pays-Bas, Autriche, Pologne, Portugal, Roumanie, Suède, Slovaquie, Slovénie, Espagne, République tchèque, Hongrie et Chypre

Pays de l'AELE

Islande, Liechtenstein, Norvège et Suisse

Autres pays

Royaume-Uni

D'autres pays sont disponibles sur demande. Pour plus d'informations sur les homologations radio, voir www.wika.fr ou la fiche technique de l'instrument concerné.

Les instruments portant le marquage FCC/ISED sont également autorisés aux Etats-Unis et au Canada.

Lorsqu'un identifiant unique (exemple : "Contains FCC ID : EXAMPLEID" ou "IC ID : EXAMPLEID") figure sur la plaque signalétique, l'instrument dispose d'une homologation radio valide pour les Etats-Unis et le Canada. L'identifiant d'homologation unique pour chaque instrument, voir chapitre "[1. Généralités](#)".

Le logo FCC indique que l'instrument est conforme aux réglementations CEM des Etats-Unis.



Si un pays ne figure pas dans la liste, les informations relatives à l'utilisation des produits WIKA doivent être obtenues auprès de la filiale WIKA.

L'utilisation dans d'autres pays n'est pas autorisée, voir le chapitre "[5. Approvals](#)".

2. Sécurité

2.5 Notice FC

Déclaration d'avertissements de l'Industrie Canada CNR-Gen et CNR-24

Le présent appareil est conforme aux CNR d'Industrie Canada applicables aux appareils radio exempts de licence.

L'exploitation est autorisée aux deux conditions suivantes :

1. l'appareil ne doit pas produire de brouillage, et
2. l'utilisateur de l'appareil doit accepter tout brouillage radioélectrique subi, même si le brouillage est susceptible d'en compromettre le fonctionnement.

Ce dispositif doit être installé et utilisé avec une distance minimale de 20 cm entre le radiateur et le corps humain.

Attention

Exposition au rayonnement de radiofréquences:

Cet équipement est conforme aux limites d'exposition aux radiofréquences IC fixées pour un environnement non contrôlé et aux Lignes directrices relatives à l'exposition aux radiofréquences (RF).

Colocation

Ce transmetteur ne peut pas être installé en colocation ou être utilisé avec une autre antenne ou transmetteur, quel qu'en soit le type

2.6 Notice FCC

Avertissements de la FCC

Information de la Commission fédérale des communications des États-Unis (FCC)

Déclaration d'avertissement FCC classe A

Cet équipement a été testé et se conforme bien aux limites existant pour un appareil numérique de classe A, relevant de la partie 15 des règles FCC. Ces limites sont prévues pour fournir une protection raisonnable contre des interférences nuisibles lorsque l'équipement est utilisé dans un environnement commercial. Cet équipement génère, utilise et peut rayonner de l'énergie de fréquences radio et, s'il n'est pas installé et utilisé en conformité avec le mode d'emploi, peut causer des interférences nuisibles pour les communications radio.

Faire fonctionner cet équipement dans une zone résidentielle risque de causer des interférences nuisibles, et dans ce cas l'utilisateur devra corriger les interférences à ses frais.

2. Sécurité

Déclaration d'avertissement FCC classe B

Cet équipement a été testé et se conforme bien aux limites existant pour un appareil numérique de classe B, relevant de la Partie 15 des règles FCC. These limits are designed to provide reasonable protection against harmful interference in a residential installation. This equipment generates, uses and can radiate radio frequency energy and, if not installed and used in accordance with the instructions, may cause harmful interference to radio communications. However, there is no guarantee that interference will not occur in a particular installation. Si cet équipement provoque des interférences nuisibles à la réception radio ou télévision, ce qui peut être déterminé en allumant et en éteignant l'équipement, l'utilisateur est encouragé à essayer de corriger les interférences en prenant une ou plusieurs des mesures suivantes :

- Réorienter ou déplacer l'antenne de réception.
- Augmenter la distance entre l'appareil et le récepteur.
- Brancher l'équipement sur une prise de courant située sur un circuit différent de celui sur lequel le récepteur est branché.
- Contacter le revendeur ou un technicien radio/TV expérimenté pour obtenir de l'aide.

Aucune réclamation auprès du fabricant ne peut être recevable en cas d'utilisation non conforme à l'usage prévu.

Ce produit est un instrument approuvé FCC. Les modifications apportées à l'instrument entraînent son arrêt immédiat.

Pour votre sécurité

Des câbles blindés doivent être utilisés pour une interface composite. Cela permet d'assurer une protection continue contre les brouillages de radiofréquences.

Caution

Les changements ou modifications non expressément approuvés par la partie responsable de la conformité peuvent annuler le droit d'utilisation de l'équipement par l'utilisateur. Un câble d'interface blindé doit être utilisé pour respecter les limites d'émission.

Notice FCC

Cet appareil satisfait à la section 15 de la réglementation FCC.

L'exploitation est autorisée aux deux conditions suivantes:

1. L'appareil ne doit pas produire de brouillage nuisible.
2. L'appareil doit accepter tout brouillage radioélectrique subi, même si le brouillage est susceptible de compromettre le fonctionnement.

FR

2. Sécurité

Ce dispositif doit être installé et utilisé avec une distance minimale de 20 cm entre le radiateur et le corps humain.

Caution

Mise en garde à l'exposition aux radiofréquences

Cet équipement est conforme aux limites d'exposition aux rayonnements de la FCC pour un environnement non contrôlé et respecte les directives d'exposition aux radiofréquences (RF) de la FCC.

Colocation

Ce transmetteur ne peut pas être installé en colocation ou être utilisé avec une autre antenne ou transmetteur, quel qu'en soit le type.

FR

5.3 Anatel notice

Résolution 680:

Cet équipement ne peut faire l'objet d'une protection contre les interférences nuisibles et ne doit pas causer d'interférences dans les systèmes dûment autorisés.

Résolution 715:

Pour plus d'informations, visitez le Internet d'ANATEL - www.anatel.gov.br

5.4 IFT notice

Le fonctionnement de cet appareil est autorisé aux deux conditions suivantes : (1) l'appareil ne doit pas produire de brouillage nuisible et (2) l'appareil doit accepter tout brouillage radioélectrique, même si le brouillage est susceptible de compromettre le fonctionnement.

3. Sécurité de la transmission des données

3. Sécurité de la transmission des données

Dans le cadre de la demande de liaison, une authentification mutuelle est établie entre un dispositif terminal et le réseau. Cela garantit que seuls les appareils réels et autorisés sont connectés à des réseaux réels et authentiques.

Les applications WIKa sont authentifiées en matière d'origine, protégées en matière d'intégrité, protégées en matière de réplication et chiffrées. Combinée à l'authentification mutuelle, cette protection garantit que le trafic réseau n'a pas été modifié, qu'il provient d'un appareil légitime, qu'il n'est pas compris par les écoutes téléphoniques et qu'il n'a pas été intercepté et rejoué par des tiers non autorisés. De plus, le chiffrement de bout en bout protège les données des applications échangées entre les dispositifs terminaux et les serveurs d'applications.

Ces mécanismes de sécurité sont basés sur les algorithmes cryptographiques AES normalisés. Ces algorithmes ont été analysés par la communauté cryptographique pendant de nombreuses années, ils sont reconnus par le NIST (National Institute of Standards and Technology) et ils continuent d'être acceptés comme meilleure pratique de sécurité pour les réseaux et les nœuds de capteurs.

3.1 LoRaWAN®

La sécurité LoRaWAN® utilise le principe du chiffrement AES combiné à plusieurs modes de fonctionnement : CMAC2 pour la protection de l'intégrité et CTR3 pour le chiffrement. Chaque appareil LoRaWAN® est personnalisé avec une clé AES de 128 bits (AppKey) et un identifiant mondial unique (DevEUI basé sur un EUI-64) qui sont utilisés lors du processus d'authentification de l'appareil.

→ Pour en savoir plus, consulter le livre blanc officiel sur la sécurité LoRaWAN® de la LoRa Alliance® sur le site <https://lora-alliance.org>.

3.2 mioty®

Chaque point terminal possède sa propre clé cryptographique, qui permet de chiffrer sa communication. La procédure utilisée est l'algorithme de chiffrement Advanced Encryption Standard symétrique par blocs avec des clés de 128 bits (AES128). Pour vérifier l'intégrité, on utilise un code d'authentification de message basé sur le chiffrement (CMAC), qui signe le contenu du message à l'aide de la clé secrète mentionnée ci-dessus.

Informations sur la transmission sans fil

La transmission des valeurs mesurées vers une plateforme IIoT s'effectue selon un intervalle de transmission prédéfini. Les intervalles de mesure et de transmission, ainsi que les seuils d'alarme pour des valeurs mesurées particulières, peuvent être configurés à partir de la plateforme IIoT.

FR

3. Sécurité de la transmission des données

Connexion au sein d'un réseau LPWAN

L'instrument peut être connecté via une passerelle LoRaWAN® ou mioty® à une infrastructure IIoT. Pour cela, l'instrument est connecté à une passerelle LoRaWAN® ou mioty®, et les valeurs mesurées sont transférées vers l'infrastructure IIoT (par exemple, une plateforme, un PC, un appareil mobile, etc.) selon des intervalles configurables. Pour la connexion IIoT, toutes les données pertinentes pour l'enregistrement et la mise en service, ainsi que les spécifications d'interface pour le traitement ultérieur des données sont fournies. Consulter "Documentation spéciale relative aux spécifications de la communication LPWAN®" (selon l'appareil), sur le site Internet de WIKA.

FR

Le package de déploiement comprend les informations d'enregistrement suivantes :

- DevEUI/EUI (dispositif terminal de 64°bits, identifiant unique)
- AppEUI (identifiant d'application de 64 bits unique, avec LoRaWAN®)
- AppKey (clé 128 bits)
- Spécification d'interface (consulter "Documentation spéciale relative aux spécifications de la communication LPWAN®" (selon l'appareil) sur le site Internet de WIKA).



Dans le cadre d'une intégration spécifique au client, l'intégration de la charge utile doit être réalisée par le client conformément à la "Documentation spéciale relative aux spécifications de la communication LPWAN®" (selon l'appareil), consultable sur le site Internet de WIKA. Plus d'informations sur [Github.com/WIKA-Group](https://github.com/WIKA-Group).

3.3 Bluetooth® Low Energy

Le Bluetooth® Low Energy communique dans la bande ISM de 2,4 GHz sans licence et constitue une norme radio écoénergétique harmonisée à l'échelle mondiale. Le Bluetooth® Low Energy utilise 40 canaux entre 2,402 GHz et 2,480 GHz. Le chiffrement est assuré par l'algorithme de chiffrement AES 128 et par le remplacement de la clé distribuée. L'instrument transmet les valeurs de pression et de température mesurées en tant que message de diffusion supplémentaire sur les canaux de publicité 37, 38 et 39, ainsi que le nom de l'instrument et l'état de charge de la batterie.

Vous trouverez plus d'informations, la configuration détaillée et les options de commande via la connexion point à point.

L'appairage est établi à l'aide d'une méthode de saisie de clé d'accès et nécessite la saisie d'un code de sécurité.



L'appairage est établi à l'aide d'une méthode de saisie de clé d'accès et nécessite la saisie d'un code de sécurité. Les réglages de l'instrument ne sont accessibles qu'une fois l'appairage effectué. La clé d'appairage de chaque instrument est aléatoire. La clé d'appairage initiale se trouve dans le guide de prise en main fourni.

3. Sécurité de la transmission des données



Si vous vous trompez 5 fois dans le code de sécurité, la connexion de l'instrument avec ce code se bloque. Vous disposez de 5 nouvelles tentatives après avoir mis l'instrument hors tension ou retiré la batterie. Si cela est impossible pour des raisons techniques, par exemple parce que vous ne pouvez pas accéder au capteur pour ouvrir le boîtier, contacter l'assistance technique.

3.4 Contenu du code QR sur la plaquette signalétique (exemple)



LW:D0:70B3D597B0000002:70B3D597B0004D71:02A30002:S1A01FZFCOJ6:PD1883F69EBE3:CC9B3

Sommaire	Identifiant	Exemple : LoRaWAN® PEW-1000 (Lxx) (illustré)	Exemple : mioty® PEW- 1000 (Mxx)	Commentaire
Préface	-	LW	MI	Identifiant technologique
SchemalD	-	D0	D0	-
JoinEUI (64 bit)	-	70B3D597B0000002	-	JoinEUI = AppEUI
DevEUI (64 bit)	-	70B3D597B0004D71	-	-
ProfileID	-	02A30002	-	02A3 = VendorID WIKA; 0002 = 4 derniers chiffres du JoinEUI
EUI	-	-	70B3D597B0000025	mioty® EUI
SerNum	S	1A01FZFCOJ6	1A01N14MPIG	Numéro de série alphanumérique WIKA (11 chiffres)
Propriétaire	P	PE526EA6D495E	PE526EA6D495E	Adresse MAC BT : E5:26:EA:6D:49:5E
Checksum	C	C9B3	8F3E	-

FR

4. Informations sur la transmission sans fil

4. Informations sur la transmission sans fil

4.1 LoRaWAN®

Bande de fréquence	Marquage de la bande de fréquence	Puissance de transmission	Pays/Régions
868,1 ... 868,5 MHz	EU868	Max. 14 dBm	Europe
902 ... 928 MHz	US915	Max. 36 dBm	North America
915 ... 928 MHz	AU915	Max. 30 dBm	Australie
915 ... 928 MHz	AS923	Max. 16 dBm	Asia
470 ... 510 MHz	CN470	Max. 19,15 dBm	Chine
865 ... 868 MHz	IN865	Max. 30 dBm	Inde
920 ... 923 MHz	KR920	Max. 14 dBm	Corée du Sud

4.2 mioty®







Bande de fréquence	Marquage de la bande de fréquence	Puissance de transmission	Pays/Régions
868,1 ... 868,5 MHz	EU868	Max. 14 dBm	Europe
902 ... 928 MHz	US915	Max. 36 dBm	North America
470 ... 510 MHz	CN470	Max. 19,15 dBm	Chine
865 ... 868 MHz	IN865	Max. 30 dBm	Inde



Certaines gammes de fréquences ne sont disponibles que sur demande. Pour plus d'informations sur les homologations radio, voir le site Internet www.wika.com.
L'étiquetage des radiofréquences diffère d'un pays à l'autre.

5. Agréments

5. Agréments

Logo	Description	Région
	<p>Déclaration de conformité UE</p> <p>RED - Directive relative aux équipements radio EN 300 220-1 et EN 300 220-2, une gamme de fréquence harmonisée 868 ... 870 Mhz est utilisée ; LoRaWAN® ou mioty®, puissance de transmission max. 14 dBm. L'instrument peut être utilisé sans restriction dans l'UE et dans les pays de l'AELE.</p>	Union européenne
	<p>Loi radio japonaise Homologation radio</p>	Japon
	<p>FCC (Federal Communications Commission) pour les Etats-Unis Homologation radio → Lorsqu'un identifiant clair (exemple : "FCC ID : EXAMPLEID") figure sur la plaque signalétique, cela signifie que l'instrument dispose d'une homologation radio valide pour les Etats-Unis. → Le logo FCC indique que l'instrument est conforme aux réglementations CEM des Etats-Unis.</p>	Etats-Unis
-	<p>ISED (Innovation, Science and Economic Development) pour le Canada Homologation radio → Si le texte "Contains IC: X8WBC805M" figure sur la plaque signalétique, l'instrument dispose d'une homologation radio valide pour le Canada.</p>	Canada
-	<p>ICASA (Independent Communications Authority of South Africa) Certification radio</p>	Afrique du Sud
	<p>Radiocommunications Equipment Rules Homologation radio Australie - ABN 49 004 465 936 Nouvelle-Zélande - N° d'entreprise 400909</p>	Australie et Nouvelle-Zélande
	<p>IFT Instituto Federal de Telecomunicaciones Radio approval</p>	Mexique
	<p>Agência Nacional de Telecomunicações Homologation radio</p>	Brésil

FR

5. Agréments



Certaines homologations ne sont disponibles que sur demande. Pour plus d'informations sur les homologations radio, voir le site Internet www.wika.com.

FR

Contenido

Contenido

1. Información general	50
2. Seguridad	53
3. Seguridad en la transmisión de datos	59
4. Información sobre la transmisión inalámbrica	62
5. Homologaciones	63

ES

Puede consultar las declaraciones de conformidad en www.wika.es.

© 02/2024 WIKA Alexander Wiegand SE & Co. KG

Reservados todos los derechos.

WIKA® es una marca protegida en varios países.

1. Información general

Documentación complementaria:

- Consulte toda la documentación incluida en el volumen de suministro.



Antes de la puesta en servicio del instrumento, debe tenerse en cuenta el manual de instrucciones del instrumento correspondiente.

1. Información general

ES

- El instrumento descrito en el manual de instrucciones está construido y fabricado según el estado actual de la técnica. Todos los componentes están sometidos durante su fabricación a estrictos criterios de calidad y medioambientales. Nuestros sistemas de gestión están certificados según ISO 9001 e ISO 14001.
- Este manual de instrucciones proporciona indicaciones importantes acerca del manejo del instrumento. Para un trabajo seguro, es imprescindible cumplir con todas las instrucciones de seguridad y manejo indicadas.
- Cumplir siempre las normativas sobre la prevención de accidentes y las normas de seguridad en vigor en el lugar de utilización del instrumento.
- El manual de instrucciones es una parte integrante del instrumento y debe guardarse en la proximidad del mismo para que el personal especializado pueda consultarlo en cualquier momento. Entregar el manual de instrucciones al usuario o propietario siguiente del instrumento.
- El personal especializado debe haber leído y entendido el manual de instrucciones antes de comenzar cualquier trabajo.
- En caso de interpretación diferente de las instrucciones de uso traducidas y las inglesas, prevalecerá la redacción inglesa.
- Si está disponible, la documentación suministrada por el proveedor también se considera parte del producto, además de estas instrucciones de uso.
- Se aplican las condiciones generales de venta incluidas en la documentación de venta.
- Modificaciones técnicas reservadas.

- Para obtener más información consultar:
 - Página web: www.wika.es / www.wika.com
 - Contacto: [Tel.: +34 933 938 630](mailto:info@wika.es)
info@wika.es

1. Información general

Modelo	FCC class	FCC ID	IC ID	Hoja técnica
NETRIS®1	B	Contiene FCC IDs: VPYCMABZ	Contiene IC IDs: 772C-CMABZ	AC 40.01
NETRIS®2	B	Contiene FCC IDs: VPYCMABZ	Contiene IC IDs: 772C-CMABZ	AC 40.02
NETRIS®3 ¹⁾	A	2BQILN3US915	34256-N3US915	AC 40.03
NETRIS®F	B	Contiene FCC IDs: VPYCMABZ	Contiene IC IDs: 772C-CMABZ	AC 40.10
PEW-1000	B	Contiene FCC IDs: VPYCMABZ	Contiene IC IDs: 772C-CMABZ	PE 87.23
PGW2x.100	-	-	-	PV 42.02
TRW	B	Contiene FCC IDs: VPYCMABZ	Contiene IC IDs: 772C-CMABZ	TE 63.04
GD-20-W	B	Contiene FCC IDs: VPYCMABZ	Contiene IC IDs: 772C-CMABZ	SP 60,78

1) Este es un equipo de la clase de emisión A y está previsto para funcionar en entornos industriales.

ES

1. Información general

1.1 Abreviaturas, definiciones

■	Símbolo de enumeración
▶	Instrucción
1. ... x.	Seguir las instrucciones paso a paso
→	Ver ... referencias cruzadas
FCC ID	Identificador único de la Comisión Federal de Comunicaciones (FCC)
DevEUI/EUI	Identificador único e irreplicable para cada instrumento (de fábrica) LoRa®/mioty®.
EUI64	El identificador único ampliado de 64 bits es un formato de dirección MAC normalizado por el IEEE para la identificación de dispositivos de red.
IEEE	Institute of Electrical and Electronics Engineers
AES	Advanced Encryption Standard
CTR	Counter
CMAC	Cipher-based Message Authentication Code
NIST	National Institute of Standards and Technology

1.2 Explicación de símbolos y términos



Información

... destaca consejos y recomendaciones útiles así como informaciones para una utilización eficiente y libre de errores.

2. Seguridad

2. Seguridad

2.1 Uso conforme a lo previsto

Las soluciones IloT transmiten los valores medidos a una nube vía radio, dependiendo del instrumento y la especificación en diferentes industrias, países y regiones. Debido a los distintos países y regiones, existen diferencias en las homologaciones individuales de radio, las bandas de frecuencia y su potencia de transmisión. Al seleccionar el país o la región, se presupone que el usuario ha comprobado la idoneidad de la banda de frecuencias seleccionada con respecto a las normativas y homologaciones pertinentes para evitar interferencias e infracciones de radiofrecuencia.

El instrumento ha sido diseñado y construido únicamente para la finalidad aquí descrita y debe utilizarse en conformidad a la misma.

Deben observarse las especificaciones técnicas de los respectivos instrumentos, véanse los manuales de instrucciones de los mismos. Se supone que el instrumento se manipula correctamente y dentro de sus especificaciones técnicas. En caso contrario, el aparato debe ponerse fuera de servicio inmediatamente y ser inspeccionado por un técnico autorizado de WIKA.

2.2 Uso incorrecto

Cualquier uso que exceda o difiera del uso previsto se considera un uso inadecuado. Consulte el manual de instrucciones de cada instrumento.

ES

2. Seguridad

2.3 Rótulos, marcajes de seguridad (ejemplo)

La etiqueta es una ilustración a modo de ejemplo. Las posiciones pueden variar según el producto y el diseño. El identificador único ampliado (DevEUI con LoRaWAN® y "EUI" con mioty®) es un identificador único global, que puede identificar el dispositivo final. No debe existir dos veces. Este ID se especifica en formato IEEE EUI64.

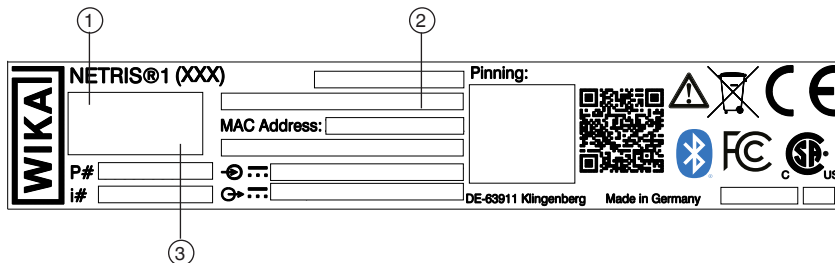

- 1 Normas radioeléctricas con especificación del "Perfil Regional WAN"
- 2 DevEUI para LoRaWAN® y EUI para mioty®
- 3 Marcas de homologación específicas de cada país, como FCC ID, IC ID, etc.

2. Seguridad

2.4 Requisitos para la transmisión inalámbrica



La utilización del módulo de radio está sujeto a las normas y reglamentos del respectivo país. El módulo sólo debe utilizarse en los países para los que se dispone de una certificación nacional. No está permitida la exportación a países para los que el producto no esté homologado.



Con esta versión del manual de instrucciones, el producto está autorizado para su uso en los siguientes países:

Países de la UE

Bélgica, Bulgaria, Dinamarca, Alemania, Estonia, Finlandia, Francia, Grecia, Irlanda, Italia, Croacia, Letonia, Lituania, Luxemburgo, Malta, Países Bajos, Austria, Polonia, Portugal, Rumanía, Suecia, Eslovaquia, Eslovenia, España, República Checa, Hungría y Chipre

Países de la AELC

Islandia, Liechtenstein, Noruega y Suiza

Otros países

Reino Unido UK

Otros países disponibles previa solicitud. Para más información sobre homologaciones radioeléctricas, consulte www.wika.es o la hoja técnica del instrumento correspondiente.

Los dispositivos con marca FCC/ISED también están aprobados para Estados Unidos y Canadá. Si en la etiqueta del producto figura un identificador único (por ejemplo: "Contiene FCC ID: EXAMPLEID" o "IC ID:EXAMPLEID"), el instrumento cuenta con una homologación de radio válida para EE.UU. y Canadá. El identificador único de aprobación de cada instrumento, véase capítulo ["1. Généralités"](#).

El logotipo de la FCC indica el cumplimiento de la normativa sobre compatibilidad electromagnética de Estados Unidos.



Si un país no está incluido en la lista, deberá obtenerse información sobre el uso de los productos WIKA en la correspondiente filial de WIKA.

No está permitido su uso en otros países, véase el capítulo ["5. Approvals"](#).

ES

2. Seguridad

2.5 Aviso IC

Advertencias IC Declaración RSS-Gen & RSS-247

Este dispositivo cumple con las normas CNR de Industria Canadá aplicables a los dispositivos de radio que no requieren licencia

La operación está permitida bajo las siguientes dos condiciones:

1. El dispositivo no debe generar interferencias y
2. El usuario del dispositivo debe aceptar cualquier interferencia radioeléctrica recibida, incluso si esta puede afectar su funcionamiento.

Este dispositivo debe instalarse y funcionar con una distancia mínima de 20 cm entre el radiador y el cuerpo humano.

Atención

Exposición a la radiación de radiofrecuencias:

Este equipo cumple con los límites de exposición a radiofrecuencias establecidos por IC para un entorno no controlado y con las Directrices sobre exposición a radiofrecuencias (RF).

Instalación

Este transmisor no puede ser instalado ni utilizado junto a otra antena o transmisor, sea cual sea su modelo.

2.6 Advertencias de la FCC

Información de la FCC (Comisión Federal de Comunicaciones)

Declaración de advertencia FCC clase A

El instrumento ha sido probado y cumple con los límites de un instrumento digital de clase A de acuerdo con la Parte 15 de las Reglas de la FCC. Los valores límite están diseñados con la protección adecuada contra interferencias perjudiciales cuando se utiliza el instrumento en un entorno comercial. El instrumento genera o utiliza energía de alta frecuencia y la irradia. El incumplimiento de las indicaciones de este manual de instrucciones puede provocar interferencias perjudiciales en la comunicación por radio.

El funcionamiento de este equipo en una zona residencial puede causar interferencias perjudiciales, en cuyo caso el usuario deberá corregir las interferencias a su cargo.

ES

2. Seguridad

Declaración de advertencia FCC clase B

Este equipo ha sido probado y se ha comprobado que cumple con los límites de un dispositivo digital de clase A, de conformidad con la parte 15 de las normas de la FCC. Los valores límites apuntan a garantizar una adecuada protección contra interferencias si se instala en una zona residencial. Este equipo genera, utiliza y emite energía en forma de frecuencias de radio, lo que, en caso de instalación y uso haciendo caso omiso de las instrucciones, puede provocar interferencias nocivas en las comunicaciones de radio. No obstante, no hay garantía alguna de que en determinadas instalaciones no se produzcan interferencias. Si este equipo causa interferencias perjudiciales en la recepción de radio o televisión, lo que puede determinarse apagando y encendiendo el equipo, se recomienda al usuario que intente corregir la interferencia mediante una o más de las siguientes medidas:

- Reoriente o reubique la antena receptora.
- Aumente la separación entre el equipo y el receptor.
- Conecte el equipo a una toma de corriente de un circuito distinto al que está conectado el receptor.
- Consulte al distribuidor o a un técnico experto en radio/TV para obtener ayuda.

No se admite ninguna reclamación debido a un manejo no adecuado.

Este producto es un instrumento aprobado por la FCC. Si se realizan modificaciones en el instrumento, éste se apaga inmediatamente.

Para su propia seguridad

Deben utilizarse cables blindados para una interfaz compuesta. De este modo se garantiza una protección continua contra las interferencias de radiofrecuencia.

Cuidado

Los cambios o modificaciones no aprobados expresamente por la parte responsable del cumplimiento podrían anular la autoridad del usuario para utilizar el equipo. Debe utilizarse un cable de interfaz apantallado para respetar los límites de emisión.

Aviso FCC

Este instrumento cumple con la parte 15 de las normas FCC.

La operación está supeditada a las siguientes condiciones:

1. Este instrumento no debe provocar interferencia dañinas.
2. Este instrumento debe absorber todas las interferencias recibidas, incluyendo interferencias que pudieran provocar un funcionamiento accidental.

ES

2. Seguridad

Este dispositivo debe instalarse y funcionar con una distancia mínima de 20 cm entre el radiador y el cuerpo humano.

Exposición a la radiación de radiofrecuencia

Este equipo cumple con los límites de exposición a la radiación del FCC establecidos para un entorno no controlado y cumple con las Directrices de exposición a radiofrecuencia (RF) del FCC.

Coubicación

Este transmisor no debe colocarse ni utilizarse junto con ninguna otra antena o transmisor.

5.5 Aviso Anatel

Resolución 680:

Este equipo no puede protegerse contra interferencias perjudiciales y no debe causar interferencias en sistemas debidamente autorizados.

Resolución 715:

Para más información, véase el sitio web de ANATEL - www.anatel.gov.br

5.6 Aviso IFT

La operación de este equipo está sujeta a las siguientes dos condiciones: (1) es posible que este equipo o dispositivo no cause interferencia perjudicial y (2) este equipo o dispositivo debe aceptar cualquier interferencia, incluyendo la que pueda causar su operación no deseada.

ES

3. Seguridad en la transmisión de datos

3. Seguridad en la transmisión de datos

Como parte de la solicitud de adhesión, se establece una autenticación mutua entre un dispositivo final y la red. Esto garantiza que sólo los dispositivos reales y autorizados se conecten a redes reales y auténticas.

Las aplicaciones WIKa están autenticadas en origen, protegidas contra integridad, protegidas contra replicación y cifradas. Combinada con la autenticación mutua, esta protección garantiza que el tráfico de red no ha sido alterado, procede de un dispositivo legítimo, no se entiende por escuchas telefónicas y no ha sido interceptado y reproducido por terceros no autorizados. Además, el cifrado de extremo a extremo protege los datos de las aplicaciones intercambiados entre los dispositivos finales y los servidores de aplicaciones.

Estos mecanismos de seguridad se basan en los algoritmos criptográficos normalizados AES. Estos algoritmos han sido analizados por la comunidad criptográfica durante muchos años, están reconocidos por el NIST (National Institute of Standards and Technology) y siguen siendo aceptados como las mejores prácticas de seguridad para nodos y redes de sensores.

ES

3.1 LoRaWAN®

La seguridad de LoRaWAN® utiliza el principio criptográfico AES en combinación con varios modos de funcionamiento: CMAC2 para la protección de la integridad y CTR3 para el cifrado. Cada dispositivo LoRaWAN® se personaliza con una clave AES única de 128 bits (AppKey) y un identificador único global (DevEUI basado en EUI-64), ambos utilizados durante el proceso de autenticación del dispositivo.

→ Encontrará más información en el Libro Blanco oficial sobre seguridad LoRaWAN® de la LoRa Alliance®, en <https://lora-alliance.org>.

3.2 mioty®

Cada punto final posee su propia clave criptográfica, con la que se cifra su comunicación. El procedimiento utilizado es el estándar de cifrado avanzado simétrico por bloques con claves de 128 bits (AES128). Para verificar la integridad, se utiliza un código de autenticación de mensajes basado en cifrado (CMAC), que firma el contenido del mensaje utilizando la clave secreta mencionada anteriormente.

Información sobre la transmisión inalámbrica

La transmisión de los valores de presión medidos a una plataforma IIoT se realiza a un intervalo de transmisión preestablecido. Los intervalos de medición y transmisión, así como los límites de alarma, para determinados valores medidos pueden configurarse a través de la plataforma IIoT.

3. Seguridad en la transmisión de datos

Conexión dentro de una LPWAN

El instrumento puede conectarse a través de una pasarela LoRaWAN® o mioty® a una infraestructura IIoT. Para ello, el instrumento se conecta a una pasarela LoRaWAN® y los valores medidos se transfieren a la infraestructura IIoT (por ejemplo, plataforma, PC, dispositivo móvil, etc.) a intervalos libremente configurables.

Para la conexión IIoT, se proporcionan todos los datos relevantes para el registro y la puesta en marcha, así como una especificación de interfaz para el procesamiento posterior de los datos; consulte la "Documentación especial para las especificaciones de comunicación LPWAN®" (en función del dispositivo) en el sitio web de WIKA.

El paquete de despliegue incluye la siguiente información de registro:

- DevEUI/EUI (dispositivo final de 64 bits, identificador único)
- AppEUI (único de 64 bits, identificador de la aplicación con LoRaWAN®)
- AppKey (llave de 128 bits)
- Especificación de interfaz (véase la documentación adicional "Documentación especial para las especificaciones de comunicación LoRaWAN®, según el modelo)" en la página web de WIKA)



En caso de una integración específica del cliente, la integración de la carga útil debe ser realizada por el cliente de acuerdo con la "Documentación especial para las especificaciones de comunicación LoRaWAN®," (según el modelo), web de WIKA.

Más información en [Github.com/WIKA-Group](https://github.com/WIKA-Group).

3.3 Bluetooth® Low Energy

Bluetooth® Low Energy se comunica en la banda ISM de 2,4 GHz, libre de licencia, y es una norma de radio de bajo consumo armonizada a escala mundial. Bluetooth® Low Energy utiliza 40 canales entre 2,402 GHz y 2,480 GHz. El cifrado se realiza mediante el algoritmo de cifrado AES 128 en combinación con la sustitución distribuida de claves. El instrumento transmite el valor de presión y temperatura como mensaje de difusión adicional en los canales de aviso 37, 38 y 39, además del nombre del instrumento y el nivel de carga de la batería.

Puede obtener más información y opciones detalladas de configuración y comandos a través de una conexión punto a punto.

El emparejamiento se establece mediante un método de introducción de claves y requiere la introducción de un código de seguridad.



El emparejamiento se establece mediante un método de introducción de claves y requiere la introducción de un código de seguridad. Sólo se puede acceder a los ajustes del instrumento una vez completado el emparejamiento. La clave de emparejamiento de cada instrumento es aleatoria. La clave de emparejamiento inicial se encuentra en la guía de inicio rápido adjunta.

3. Seguridad en la transmisión de datos



Si el código de seguridad se introduce incorrectamente 5 veces, el instrumento se bloquea para la conexión con este código. Tras desconectar la alimentación de tensión o retirar la pila, se dispone de nuevo de 5 intentos. Si esto no es posible por razones técnicas, por ejemplo, porque no se puede alcanzar el sensor para abrir la caja, póngase en contacto con el servicio técnico.

3.4 Contenido del código QR en la etiqueta del producto (ejemplo)



LW:D0:70B3D597B0000002:70B3D597B0004D71:02A30002:S1A01FZFCOJ6:PD1883F69EBE3:CC9B3

Contenido	Identificador	Ejemplo LoRaWAN® PEW-1000 (Lxx) (en la imagen)	Ejemplo mioty® PEW-1000 (Mxx)	Nota
Prefación	-	LW	MI	Identificador tecnológico
SchemalD	-	D0	D0	-
JoinEUI (64 bit)	-	70B3D597B0000002	-	JoinEUI = AppEUI
DevEUI (64 bit)	-	70B3D597B0004D71	-	-
ProfileID	-	02A30002	-	02A3 = VendorID WIKA; 0002 últimos 4 dígitos del JoinEUI
EUI	-	-	70B3D597B0000025	mioty® EUI
SerNum	S	1A01FZFCOJ6	1A01N14MPIG	Número de serie alfanumérico WIKA (11 dígitos)
Propietario	P	PE526EA6D495E	PE526EA6D495E	Dirección BT MAC: E5:26:EA:6D:49:5E
CheckSum	C	C9B3	8F3E	-

4. Información sobre la transmisión inalámbrica

4. Información sobre la transmisión inalámbrica

5.7 LoRaWAN®

Banda de frecuencias	Marcado de la banda de frecuencias	Potencia de transmisión	Países/Regiones
868,1 ... 868,5 MHz	EU868	Max. 14 dBm	Europa
902 ... 928 MHz	US915	Max. 36 dBm	América del Norte
915 ... 928 MHz	AU915	Max. 30 dBm	Australia
915 ... 928 MHz	AS923	Max. 16 dBm	Asia
470 ... 510 MHz	CN470	Max. 19,15 dBm	China
865 ... 868 MHz	IN865	Max. 30 dBm	India
920 ... 923 MHz	KR920	Max. 14 dBm	Corea del Sur

5.8 mioty®

Banda de frecuencias	Marcado de la banda de frecuencias	Potencia de transmisión	Países/Regiones
868,1 ... 868,5 MHz	EU868	Max. 14 dBm	Europa
902 ... 928 MHz	US915	Max. 36 dBm	América del Norte
470 ... 510 MHz	CN470	Max. 19,15 dBm	China
865 ... 868 MHz	IN865	Max. 30 dBm	India









Algunas gamas de frecuencias sólo están disponibles bajo pedido. Para más información sobre los protocolos de radio, consulte www.wika.com.

El etiquetado de radiofrecuencia difiere de un país a otro.

5. Homologaciones

5. Homologaciones

Logo	Descripción	Región
	Declaración de conformidad UE RED - Directiva sobre equipos radioeléctricos EN 300 220-1 y EN 300 220-2, se utiliza la gama de frecuencias armonizadas 868 ... 870 Mhz; LoRaWAN® o mioty®, potencia máxima de transmisión 14 dBm. El instrumento puede utilizarse sin restricciones en la UE y en los países de la AELC.	Unión Europea
	Ley de Radio de Japón Aprobación de la radio	Japón
	Comisión Federal de Comunicaciones (FCC) de EE.UU. Aprobación de la radio → Si hay un identificador claro (ejemplo: "FCC ID: EXAMPLEID") en su etiqueta de producto, el instrumento tiene una aprobación de radio válida para los EE.UU. → El logotipo de la FCC indica el cumplimiento de la normativa sobre compatibilidad electromagnética de Estados Unidos.	USA
-	Innovación, Ciencia y Desarrollo Económico (ISED) para Canadá Aprobación de la radio → Si el texto "Contiene IC: X8WBC805M" figura en la etiqueta del producto, el instrumento dispone de una homologación de radio válida para Canadá.	Canadá
-	ICASA (Autoridad Independiente de Comunicaciones de Sudáfrica) Certificación de radio	Sudáfrica
	Reglamento de equipos de radiocomunicaciones Aprobación de la radio Australia - ABN 49 004 465 936 Nueva Zelanda - número de empresa 400909	Australia y Nueva Zelanda
	IFT Instituto Federal de Telecomunicaciones Radio approval	México
	Agência Nacional de Telecomunicações Aprobación de la radio	Brasil

ES

5. Homologaciones



Algunas homologaciones sólo están disponibles previa solicitud. Para más información sobre los protocolos de radio, consulte www.wika.com.

ES

Conteúdo

Conteúdo

1. Informações gerais	66
2. Segurança	68
3. Segurança na transmissão de dados	74
4. Informações sobre transmissão sem fio	78
5. Aprovações	79

PT

Declarações de conformidade podem ser encontradas no site www.wika.com.br.

1. Informações gerais

Documentação complementar:

- ▶ Siga toda a documentação incluída no escopo de fornecimento.



Antes de colocar o instrumento em funcionamento, é necessário consultar o manual de instruções do instrumento em questão.

1. Informações gerais

- O instrumento descrito nas instruções de operação foi projetado e fabricado com o uso de tecnologia de ponta. Todos os componentes estão sujeitos a rigorosos critérios de qualidade e ambientais durante a produção. Nossos sistemas de gestão da qualidade são certificados de acordo com as normas ISO 9001 e ISO 14001.
- Estas instruções de operação contém informações importantes relativas à utilização do instrumento. O cumprimento de todas as instruções de segurança e de trabalho é condição essencial para garantir um trabalho seguro.
- Observe atentamente as normas locais de prevenção de acidentes e os regulamentos gerais de segurança apropriados para a faixa de uso deste equipamento.
- As instruções de operação fazem parte do produto, e devem ser mantidas nas imediações, de forma facilmente acessível aos profissionais qualificados. Passe as instruções de operação ao próximo usuário ou proprietário do instrumento.
- Os profissionais qualificados devem ler cuidadosamente as instruções antes de dar início a qualquer trabalho.
- No caso de uma interpretação diferente das instruções de operação traduzidas e em inglês, os termos em inglês devem prevalecer.
- Se disponível, a documentação do fornecedor entregue também deve ser considerada parte do produto, além destas instruções de operação.
- Os termos e condições gerais contidos na documentação de venda devem ser considerados.
- Sujeito a alterações técnicas.

- Para mais informações:
 - Página da Internet: www.wika.com.br / www.wika.com
 - Contato: [Tel.: +49 9372 132-0](tel:+4993721320)
vendas@wika.com.br

PT

1.1 Abreviações, definições

■	Projétil
▶	Instruções
1. ... x.	Siga as instruções passo a passo
→	Veja ... referências cruzadas
FCC ID	Identificador único da Comissão Federal de Comunicações (FCC)
DevEUI/EUI	Identificador único e exclusivo para cada instrumento (na fábrica) LoRa®/mioty®
EUI64	O identificador único estendido de 64 bits é um formato de endereço MAC padronizado pelo IEEE para a identificação de dispositivos de rede.
IEEE	Instituto de Engenheiros Eletricistas e Eletrônicos
AES	Padrão de Criptografia Avançada
CTR1000	Contador
CMAC	Código de autenticação de mensagem baseado em cifra
NIST	Instituto Nacional de Padrões e Tecnologia

1.2 Explicação de símbolos e termos



Informação

... aponta dicas úteis, recomendações e informações para uma operação eficiente e sem problemas.

2. Segurança

2. Segurança

2.1 Uso previsto

As soluções de IIoT transmitem os valores medidos para a nuvem via rádio, dependendo do instrumento e das especificações em diferentes setores, países e regiões. Devido às diferenças entre países e regiões, existem diferenças nas autorizações de radiodifusão, nas bandas de frequência e respectiva potência de transmissão. Ao selecionar o país ou a região, presume-se que o usuário tenha verificado se a banda de frequência selecionada está em conformidade com as normas e aprovações aplicáveis, a fim de evitar interferências de radiofrequência e infrações.

O instrumento foi projetado e fabricado exclusivamente para o uso aqui descrito, e só pode ser usado dessa forma.

As especificações técnicas dos respectivos instrumentos devem ser respeitadas; consulte o manual de instruções do respectivo instrumento. Partimos da hipótese de que o instrumento seja manuseado corretamente, dentro de suas especificações técnicas. Caso contrário, o instrumento deverá ser retirado de serviço imediatamente, e inspecionado por um engenheiro especialista autorizado pela WIKA.

2.2 Uso impróprio

Qualquer uso que exceda ou difira da finalidade prevista é considerado uso indevido; consulte as instruções de operação do instrumento em questão.

PT

2. Segurança

2.3 Identificação, marcações de segurança (exemplo)

A etiqueta é um exemplo ilustrativo. As posições podem variar dependendo do produto e do design.

O identificador único estendido (DevEUI no LoRaWAN® e “EUI” no mioty®) é um identificador único global, capaz de identificar o dispositivo final. Não pode existir duas vezes. Este ID é especificado no formato IEEE EUI64.

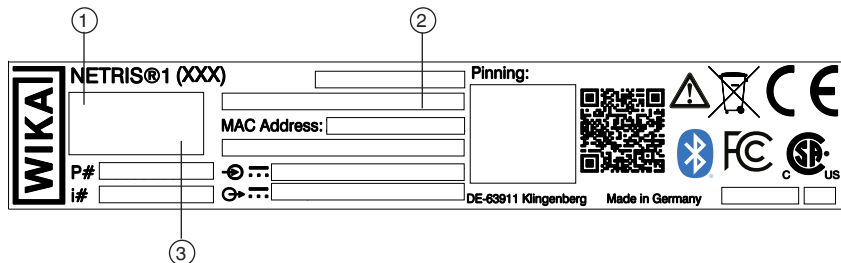

- 1 Normas de rádio com especificação de “Regional Profile WAN”
- 2 DevEUI para LoRaWAN® e “EUI” para mioty®
- 3 Marcas de aprovação específicas de cada país, como FCC ID, IC ID, etc.

2.4 Requisitos para transmissão sem fio



A utilização do aparelho de rádio está sujeita às disposições e regulamentos do respectivo país. O módulo só pode ser utilizado nos países para os quais existe uma certificação nacional disponível. Não é permitida a exportação para países nos quais o produto não possui aprovação.

2. Segurança



Com esta versão do manual de instruções, o instrumento está aprovado para uso nos seguintes países:

Países da UE

Bélgica, Bulgária, Dinamarca, Alemanha, Estónia, Finlândia, França, Grécia, Irlanda, Itália, Croácia, Letónia, Lituânia, Luxemburgo, Malta, Países Baixos, Áustria, Polónia, Portugal, Romênia, Suécia, Eslováquia, Eslovênia, Espanha, República Tcheca, Hungria e Chipre

Países da EFTA

Islândia, Liechtenstein, Noruega e Suíça

Outros países

Reino Unido

Outros países disponíveis mediante solicitação. Para obter mais informações sobre certificações de rádio, consulte www.wika.com ou a ficha técnica do respectivo instrumento.

Os instrumentos com a marcação FCC/ISED também são permitidos nos EUA e no Canadá. Se um identificador único (por exemplo: "Contém FCC ID: EXAMPLEID" ou "IC ID:EXAMPLEID") estiver presente na etiqueta do produto, o instrumento possui uma certificação de radiocomunicações válida para os EUA e o Canadá. O ID de aprovação exclusivo para cada instrumento; consulte o capítulo "[1. Informações gerais](#)".

O logotipo da FCC indica conformidade com as normas de compatibilidade eletromagnética (EMC) dos Estados Unidos.



Caso um país não conste da lista, as informações sobre o uso dos produtos WIKA devem ser obtidas junto à filial da WIKA.

O uso em outros países não é permitido; consulte o capítulo "[5. Aprovações](#)".

2. Segurança

2.5 Aviso do IC

IC warnings RSS-Gen & RSS-247 statement

Este dispositivo está em conformidade com as normas RSS isentas de licença do Industry Canada.

A operação está sujeita às duas seguintes condições:

1. Este aparelho não deve causar interferências.
2. Este aparelho deve tolerar qualquer interferência, incluindo aquelas que possam causar um funcionamento indesejado do aparelho.

Este aparelho deve ser instalado e utilizado mantendo uma distância mínima de 20 cm entre o radiador e o corpo humano.

Atenção

Exposição à radiação de radiofrequência:

Este equipamento está em conformidade com os limites de exposição à radiação estabelecidos pela IC para ambientes não controlados e cumpre as Diretrizes de Exposição à Radiofrequência (RF) da IC.

Colocação conjunta

Este transmissor não deve ser instalado no mesmo local nem operado em conjunto com qualquer outra antena ou transmissor.

2.6 Aviso FCC

Informações vindas da FCC (Federal Communications Commission)

Declaração de advertência da FCC, classe A

O instrumento foi testado e está em conformidade com os limites estabelecidos para instrumentos digitais da classe A, de acordo com a Parte 15 das Normas da FCC. Os valores-limite foram definidos de modo a garantir proteção adequada contra interferências prejudiciais durante a operação do instrumento em um ambiente comercial. O aparelho gera ou utiliza energia de alta frequência e a irradia. O não cumprimento das instruções contidas neste manual de instruções pode causar interferências prejudiciais nas comunicações por rádio.

A utilização deste equipamento em uma área residencial pode causar interferências prejudiciais; nesse caso, o usuário deverá corrigir a interferência às suas próprias custas.

PT

2. Segurança

Declaração de advertência da FCC, classe B

Este instrumento foi testado e está em conformidade com os limites para um instrumento digital classe A, nos termos da parte 15 das regras do FCC. Estes limites são projetadas para prover proteção adequada contra interferências prejudiciais em instalações residenciais. Este equipamento gera, usa, e pode irradiar energias de radiofrequência, e se não for montado e utilizado conforme as instruções, pode causar interferências prejudiciais à comunicação de rádio. Entretanto, não há garantia que a interferência não irá ocorrer em uma instalação particular. Caso este equipamento cause interferência prejudicial à recepção de rádio ou televisão, o que pode ser verificado ligando e desligando o equipamento, recomenda-se ao usuário que tente corrigir a interferência adotando uma ou mais das seguintes medidas:

- Reorientar ou reposicione a antena receptora.
- Aumente a distância entre o equipamento e o receptor.
- Conecte o equipamento a uma tomada em um circuito diferente daquele ao qual o receptor está conectado.
- Consulte o revendedor ou um técnico experiente em rádio e TV para obter ajuda.

PT

O fabricante não se responsabiliza por qualquer reclamação baseada no uso contrário ao pretendido. Este produto é um aparelho aprovado pela FCC. Alterações no instrumento provocam o desligamento imediato do mesmo.

Para sua própria segurança

Devem ser utilizados cabos blindados para uma interface composta. O objetivo é garantir a proteção contínua contra interferências de radiofrequência.

Cuidado

Alterações ou modificações não aprovadas expressamente pela entidade responsável pela conformidade podem invalidar a autorização do usuário para operar o equipamento. É necessário utilizar um cabo de interface blindado para cumprir os limites de emissão.

Aviso FCC

Este aparelho está em conformidade com a Parte 15 das normas da FCC.

A operação está sujeita às duas seguintes condições:

1. Este aparelho não deve causar interferências prejudiciais.
2. Este dispositivo deve aceitar qualquer interferência recebida, incluindo interferências que possam causar um funcionamento indesejado.

Este aparelho deve ser instalado e utilizado mantendo uma distância mínima de 20 cm entre o radiador e o corpo humano.

2. Segurança

Atenção: Exposição à radiação de radiofrequência

Este equipamento está em conformidade com os limites de exposição à radiação estabelecidos pela FCC para um ambiente não controlado e cumpre as Diretrizes de Exposição à Radiofrequência (RF) da FCC.

Colocação conjunta

Este transmissor não deve ser instalado no mesmo local nem operado em conjunto com qualquer outra antena ou transmissor.

2.7 Comunicado da Anatel

Resolução 680:

Este equipamento não pode ser protegido contra interferências prejudiciais e não deve causar interferências em sistemas devidamente autorizados.

Resolução 715:

Para mais informações, acesse o site da ANATEL - www.anatel.gov.br

2.8 Aviso do IFT

A operação deste equipamento está sujeita às duas condições a seguir: (1) este equipamento ou instrumento não deve causar interferência prejudicial e (2) este equipamento ou instrumento deve aceitar qualquer interferência, incluindo interferências que possam causar funcionamento indesejado.

PT

3. Segurança na transmissão de dados

3. Segurança na transmissão de dados

Como parte da solicitação de conexão, é estabelecida uma autenticação mútua entre um dispositivo final e a rede. Isso garante que apenas dispositivos reais e autorizados sejam conectados a redes reais e autênticas.

Os aplicativos da WIKA possuem autenticação de origem, proteção de integridade, proteção contra replicação e são criptografados. Em conjunto com a autenticação mútua, essa proteção garante que o tráfego de rede não tenha sido alterado, provenha de um dispositivo legítimo, não seja interceptado por escutas e não tenha sido capturado e reproduzido por terceiros não autorizados. Além disso, a criptografia de ponta a ponta protege os dados dos aplicativos trocados entre os dispositivos finais e os servidores de aplicativos.

Esses mecanismos de segurança se baseiam nos algoritmos criptográficos AES padronizados. Esses algoritmos vêm sendo analisados pela comunidade criptográfica há muitos anos, são reconhecidos pelo NIST (Instituto Nacional de Padrões e Tecnologia) e continuam a ser considerados as melhores práticas de segurança para nós de sensores e redes.

3.1 LoRaWAN®

A segurança LoRaWAN® utiliza o princípio criptográfico da criptografia AES em combinação com vários modos de operação: CMAC2 para proteção de integridade e CTR3 para criptografia. Cada dispositivo LoRaWAN® é personalizado com uma chave AES exclusiva de 128 bits (AppKey) e um identificador único global (DevEUI baseado em EUI-64), ambos utilizados durante o processo de autenticação do dispositivo.

→ Mais detalhes podem ser encontrados no Livro Branco sobre Segurança oficial da LoRaWAN® da LoRa Alliance®, consulte <https://lora-alliance.org>.

3.2 mioty®

Cada ponto final possui sua própria chave criptográfica, com a qual sua comunicação é criptografada. O procedimento utilizado é o Padrão de Criptografia Avançada simétrico por blocos com chaves de 128 bits (AES128). Para verificar a integridade, se utiliza um Código de Autenticação de Mensagem baseado em cifra (CMAC), que assina o conteúdo da mensagem usando a chave secreta mencionada acima.

Informações sobre transmissão sem fio

A transmissão dos valores medidos para a plataforma IIoT é realizada em um intervalo de transmissão predefinido. Os intervalos de medição e transmissão, bem como os limites de alarme, para determinados valores medidos podem ser configurados na plataforma IIoT.

3. Segurança na transmissão de dados

Conexão em uma LPWAN

O instrumento pode ser conectado a uma infraestrutura de IloT por meio de um gateway LoRaWAN® ou mioty®. Para isso, o instrumento é conectado a um gateway LoRaWAN® ou mioty® e os valores medidos são transferidos para a infraestrutura IloT (por exemplo, plataforma, PC, dispositivo móvel etc.) em intervalos livremente configuráveis. Para a conexão IloT, são fornecidos todos os dados relevantes para o registro e a colocação em serviço, bem como uma especificação de interface para o processamento posterior dos dados; consulte “Documentação específica para o protocolo de comunicação LPWAN®” (dependendo do dispositivo) no site da WIKA.

O pacote de implantação inclui as seguintes informações de registro:

- DevEUI/EUI (dispositivo final de 64 bits, identificador único)
- AppEUI (identificador de aplicativo exclusivo de 64 bits, com LoRaWAN®)
- AppKey (chave de 128 bits)
- Especificação da interface (consulte “Documentação especial para o protocolo de comunicação LPWAN®” (dependendo do dispositivo) no site da WIKA.



No caso de uma integração personalizada, a integração da carga útil deve ser realizada pelo cliente, de acordo com a “Documentação especial para especificações de comunicação LPWAN®” (dependendo do dispositivo) no site da WIKA.

Para mais informações: [Github.com/WIKA-Group](https://github.com/WIKA-Group).

3.3 Bluetooth® de Baixo Consumo

Low Energy opera na banda ISM de 2,4 GHz, isenta de licença, e é um padrão de rádio energeticamente eficiente e harmonizado globalmente.

Low Energy utiliza 40 canais entre 2,402 GHz e 2,480 GHz.

A criptografia é realizada utilizando o algoritmo de criptografia AES-128 em combinação com a substituição distribuída de chaves.

O instrumento transmite os valores medidos de pressão e temperatura como uma mensagem de transmissão adicional nos canais de publicidade 37, 38 e 39, além do nome do instrumento e do nível de carga da bateria.

Mais informações, bem como opções detalhadas de configuração e comandos, estão disponíveis por meio de uma conexão ponto a ponto.

O emparelhamento é estabelecido por meio de um método de inserção de senha e requer a inserção de um código de segurança.

PT

3. Segurança na transmissão de dados



O emparelhamento é estabelecido por meio de um método de inserção de senha e requer a inserção de um código de segurança. As configurações do aparelho só podem ser acessadas após a conclusão do emparelhamento. A chave de emparelhamento de cada instrumento é aleatória. A chave de emparelhamento inicial pode ser encontrada no guia de início rápido incluído.



Se o código de segurança for digitado incorretamente 5 vezes, o aparelho será bloqueado para conexão com esse código. Após desligar a alimentação elétrica ou remover a bateria, ficam novamente disponíveis 5 tentativas. Se isso não for possível por motivos técnicos, por exemplo, porque não é possível acessar o sensor para abrir a caixa, entre em contato com o suporte técnico.

3.4 Conteúdo do código QR na etiqueta do produto (exemplo)



LW:D0:70B3D597B0000002:70B3D597B0004D71:02A30002:S1A01FZF0J6:PD1883F69EBE3:CC9B3

Conteúdo	Identificador	Exemplo LoRaWAN® PEW-1000 (Lxx) (na foto)	Exemplo mioty® PEW-1000 (Mxx)	Comentário
Prefácio	-	LW-1	MI-1	Identificador de tecnologia
ID do esquema	-	D0	D0	-
JoinEUI (64 bits)	-	70B3D597B0000002	-	JoinEUI = AppEUI
DevEUI (64 bits)	-	70B3D597B0004D71	-	-
ID do perfil	-	02A30002	-	02A3 = VendorID WIKA; 0002 últimos 4 digitais da JoinEUI
EUI	-	-	70B3D597B0000025	mioty® EUI
SerNum	S	1A01FZF0J6	1A01N14MPIG	Número de série alfanumérico da WIKA (11 digitais)

3. Segurança na transmissão de dados

Conteúdo	Identificador	Exemplo LoRaWAN® PEW-1000 (Lxx) (na foto)	Exemplo mioty® PEW-1000 (Mxx)	Comentário
Proprietário	P	PE526EA6D495E	PE526EA6D495E	Endereço MAC da BT: E5:26:EA:6D:49:5E
Checksum	C	C9B3	8F3E	-

PT

4. Informações sobre transmissão sem fio

4. Informações sobre transmissão sem fio

4.1 LoRaWAN®

Banda de frequência	Marcação da banda de frequência	Potência de transmissão	Países/regiões
868,1 ... 868,5 MHz	EU	Máx. 14 dBm	Europa
902 ... 928 MHz	US	Máx. 36 dBm	América do norte
915 ... 928 MHz	AU	Máx. 30 dBm	Austrália
915 ... 928 MHz	AS	Máx. 16 dBm	Ásia
470 ... 510 MHz	CN202111548816.4	Máx. 19,15 dBm	China
865 ... 868 MHz	IN	Máx. 30 dBm	Índia
920 ... 923 MHz	KR920	Máx. 14 dBm	Coreia do Sul

4.2 mioty®







Banda de frequência	Marcação da banda de frequência	Potência de transmissão	Países/regiões
868,1 ... 868,5 MHz	EU	Máx. 14 dBm	Europa
902 ... 928 MHz	US	Máx. 36 dBm	América do norte
470 ... 510 MHz	CN202111548816.4	Máx. 19,15 dBm	China
865 ... 868 MHz	IN	Máx. 30 dBm	Índia



Algumas faixas de frequência estão disponíveis apenas mediante solicitação. Para obter mais informações sobre aprovações de equipamentos de rádio, consulte www.wika.com. A identificação por radiofrequência varia de país para país.

5. Aprovações

5. Aprovações

Logotipo	Descrição	Região
	Declaração de conformidade UE RED - Diretriz de equipamento de rádio EN 300 220-1 e EN 300 220-2, se utiliza a faixa de frequência harmonizada de 868 ... 870 Mhz; LoRaWAN® ou mioty®, potência máx. de transmissão de 14 dBm. O instrumento pode ser utilizado sem restrições na UE e nos países da EFTA.	União Europeia
	Legislação sobre Rádio do Japão Aprovação de rádio	Japão
	Federal Communications Commission (FCC) para os EUA Aprovação de rádio → Se houver um identificador claro (por exemplo: „FCC ID: EXAMPLEID“ ou „IC: 12345-ABCDE“) na etiqueta do produto, o aparelho possui uma certificação de radiocomunicações válida para os EUA. O logotipo da FCC indica conformidade com as normas de compatibilidade eletromagnética (EMC) dos Estados Unidos.	EUA
-	Innovation, Science and Economic Development (ISED) para o Canadá Aprovação válida de rádio → Se o texto “Contains IC: X8WBC805M” estiver em sua etiqueta de produto, o instrumento terá uma aprovação de rádio válida para o Canadá.	Canadá
-	ICASA (Autoridade Independente de Comunicações da África do Sul) Certificação de rádio	África do Sul
	Regras para equipamentos de radiocomunicação Aprovação válida de rádio Austrália - ABN 49 004 465 936 Nova Zelândia - nº da empresa 400909	Austrália e Nova Zelândia
	IFT Instituto Federal de Telecomunicações Aprovação de rádio	México
	Agência Nacional de Telecomunicações Aprovação válida de rádio	Brasil

PT

5. Aprovações



Algumas aprovações só estão disponíveis mediante solicitação. Para mais informações sobre as homologações de rádio, consulte www.wika.com.

PT



The LoRa® brand and the LoRa logo are trademarks of Semtech Corporation.

LoRaWAN® is a trademark used under licence from LoRa-Alliance®.

mioty® is a registered trademark of Fraunhofer IIS.

The Bluetooth® word mark and logos are registered trademarks owned by Bluetooth SIG, Inc. and any use of such marks by WIKA is under licence. Other brands and trademarks are the property of their respective owners.



Importer for UK

WIKAL Instruments Ltd

Unit 6 and 7 Goya Business park

The Moor Road

Sevenoaks

Kent

TN14 5GY



WIKAL Alexander Wiegand SE & Co. KG

Alexander-Wiegand-Strasse 30

63911 Klingenberg • Germany

Tel. +49 9372 132-0

info@wika.de

www.wika.de

**Additional operating instructions
Zusatz-Betriebsanleitung
Mode d'emploi supplémentaire
Manual de instrucciones adicional
Instruções de operação adicionais**

Additional operating instructions for radio frequencies	EN
Zusatz-Betriebsanleitung für Funkfrequenzen	DE
Mode d'emploi supplémentaire pour les radiofréquences	FR
Manual de instrucciones adicional para radiofrecuencias	ES
Instruções de operação adicionais para frequências de rádio	PT



For instruments with Bluetooth®



Content

EN

1. General information	3
2. Safety	6
3. Data transmission security	12
4. Information on wireless transmission	14
5. Approvals	15

Declarations of conformity can be found online at www.wika.com.

1. General information

Supplementary documentation:

- ▶ Please follow all the documentation included in the scope of delivery.



Before commissioning the instrument, the operating instructions of the relevant instrument must be noted.

EN

1. General information

- The instrument described in the operating instructions has been designed and manufactured using state-of-the-art technology. All components are subject to stringent quality and environmental criteria during production. Our management systems are certified in accordance with ISO 9001 and ISO 14001.
- These operating instructions contain important information on handling the instrument. Working safely requires that all safety instructions and work instructions are observed.
- Observe the relevant local accident prevention regulations and general safety regulations for the instrument's range of use.
- The operating instructions are part of the product and must be kept in the immediate vicinity of the instrument and readily accessible to skilled personnel at any time. Pass the operating instructions on to the next operator or owner of the instrument.
- Skilled personnel must have carefully read and understood the operating instructions prior to beginning any work.
- In case of a different interpretation of the translated and the English operating instructions, the English wording shall prevail.
- If available, the provided supplier documentation is also considered to be part of the product in addition to these operating instructions.
- The general terms and conditions contained in the sales documentation shall apply.
- Subject to technical modifications.

- Further information:
 - Internet address: www.wika.de / www.wika.com
 - Contact: [Tel.: +49 9372 132-0](tel:+4993721320)
info@wika.de

1. General information

Model	FCC Class	FCC ID	IC ID	ANATEL	Japan TELECOM	CMIIT ID	Data sheet
NETRIS®1	B	Contains FCC ID: HSW2832	Contains IC ID: 4492A-2832	-	-	-	AC 40.01
NETRIS®F	B	Contains FCC ID: HSW2832	Contains IC ID: 4492A-2832	-	-	-	AC 40.10
PEW-1000	B	Contains FCC ID: HSW2832	Contains IC ID: 4492A-2832	-	-	-	PE 87.23
TRW	B	Contains FCC ID: HSW2832	Contains IC ID: 4492A-2832	-	-	-	TE 63.04
CPG1200	B	Contains FCC ID: X8WBC805M	Contains IC: 4100A-BC805M	02700-24-16462	Contains ID: 201-200778/00	-	CT 10.20
CPG1500	-	contains FCC ID: T7VPAN10	contains IC: 216Q-PAN10	-	017-190033	24J99453V910	CT 10.51
CPH7000	B	Contains FCC ID: T7V1316	Contains IC ID: 216Q-1316	-	-	-	CT 15.51
GDI-100-D	B	Contains FCC ID: T7VPAN10	Contains IC ID: 216Q-PAN10	-	017-190033	-	SP 60.07

EN

1. General information

1.1 Abbreviations, definitions

- Bullet
- ▶ Instruction
- 1. ... x. Follow the instruction step by step
- See ... cross-references
- FCC ID Unique identifier of the Federal Communications Commission (FCC)

EN

1.2 Explanation of symbols and terms



Information

... points out useful tips, recommendations and information for efficient and trouble-free operation.

2. Safety

2. Safety

2.1 Intended use

The WIKA solutions provide measured values and other functions in different industries and countries or regions via Bluetooth, depending on the instrument and specification. Due to the different countries and regions, there are differences in the individual radio approvals, frequency bands and their transmission power. When selecting the country or region, it is assumed that the user has checked the selected frequency band for suitability with regard to the relevant regulations and approvals in order to prevent radio-frequency interference and infringements.

The instrument has been designed and engineered solely for the intended use described here, and may only be used accordingly.

The technical specifications of the respective instruments must be observed, see operating instructions of the respective instrument. It is assumed that the instrument is handled properly and within its technical specifications. Otherwise, the instrument must be taken out of service immediately and inspected by an authorised WIKA service engineer.

The manufacturer shall not be liable for claims of any type based on operation contrary to the intended use.

2.2 Improper use

Any use beyond or different to the intended use is considered as improper use, see the operating instructions of the individual instrument.

2. Safety

2.3 Labelling, safety markings (example)

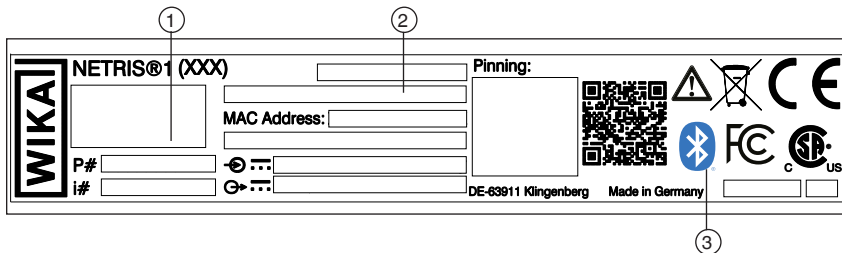

- ① Radio standard
- ② MAC address
- ③ Radio standard logo

2.4 Requirements for wireless transmission



The use of the radio unit is subject to the provisions and regulations of the respective country. The module may only be used in the countries for which a country certification is available. Export to countries for which the product has no approval is not permitted.

2. Safety

EN



With this version of the operating instructions, the instrument is approved for operation in the following countries:

EU countries

Belgium, Bulgaria, Denmark, Germany, Estonia, Finland, France, Greece, Ireland, Italy, Croatia, Latvia, Lithuania, Luxembourg, Malta, the Netherlands, Austria, Poland, Portugal, Romania, Sweden, Slovakia, Slovenia, Spain, Czech Republic, Hungary and Cyprus

EFTA countries

Iceland, Liechtenstein, Norway and Switzerland

Other countries

United Kingdom UK

Other countries available upon request. For further information on radio approvals, see www.wika.com or data sheet of the respective instrument.

Instruments with FCC/ISED marking are also permitted in USA and Canada.

If a unique identifier (example: "Contains FCC ID: EXAMPLEID" or "IC ID:EXAMPLEID") is present on its product label, the instrument has a valid radio approval for the USA and Canada. The unique approval ID for each instrument, see chapter ["1. General information"](#).

The FCC logo stands for compliance with the EMC regulations of the USA.



If a country is not included in the list, information on the use of WIKA products should be obtained from the WIKA subsidiary.

Use in other countries is not permitted, see chapter ["5. Approvals"](#).

2. Safety

2.5 IC notice

IC warnings RSS-Gen & RSS-247 statement

This device complies with Industry Canada licence-exempt RSS standard(s).

Operation is subject to the following two conditions:

1. This device may not cause interference.
2. This device must accept any interference, including interference that may cause undesired operation of the device.

Attention

Radio Frequency Radiation Exposure:

This equipment complies with IC radiation exposure limits set forth for an uncontrolled environment and meets the IC radio frequency (RF) Exposure Guidelines.

Co-location

This transmitter must not be co-located or operated in conjunction with any other antenna or transmitter.

2.6 FCC notice

Information from the FCC (Federal Communications Commission)

FCC warning statement class A

The instrument has been tested and complies with the limits of a class A digital instrument in accordance with Part 15 of the FCC Rules. The limit values are designed with adequate protection against harmful interferences when operating the instrument in a commercial environment. The instrument generates or uses high-frequency energy and radiates this. Non-compliance with the instructions in this instruction manual can lead to damaging interference in the radio communication.

Operation of this equipment in a residential area is likely to cause harmful interference in which case the user will be required to correct the interference at his own expense.

EN

2. Safety

FCC warning statement class B

This equipment has been tested and found to comply with the limits for a class B digital device, pursuant to Part 15 of the FCC rules. These limits are designed to provide reasonable protection against harmful interference in a residential installation. This equipment generates, uses and can radiate radio frequency energy and, if not installed and used in accordance with the instructions, may cause harmful interference to radio communications. However, there is no guarantee that interference will not occur in a particular installation. If this equipment does cause harmful interference to radio or television reception, which can be determined by switching the equipment off and on, the user is encouraged to try to correct the interference by one or more of the following measures:

- Reorient or relocate the receiving antenna.
- Increase the separation between the equipment and receiver.
- Connect the equipment into an outlet on a circuit different from that to which the receiver is connected.
- Consult the dealer or an experienced radio/TV technician for help.

The manufacturer shall not be liable for claims of any type based on operation contrary to the intended use. This product is an FCC-approved instrument. Modifications to the instrument lead to the instrument immediately shutdown.

For your own safety

Shielded cables should be used for a composite interface. This is to ensure continued protection against radio frequency interference.

Caution

Changes or modifications not expressly approved by the party responsible for compliance could void the user's authority to operate the equipment. Shielded interface cable must be used in order to comply with the emission limits.

FCC notice

This device complies with part 15 of the FCC rules.

Operation is subject to the following two conditions:

1. This device may not cause harmful interference.
2. This device must accept any interference received, including interference that may cause undesired operation.

This device should be installed and operated with minimum distance 20 cm between the radiator and human body.

2. Safety

Caution Radio Frequency Radiation Exposure

This equipment complies with FCC radiation exposure limits set forth for an uncontrolled environment and meets the FCC radio frequency (RF) Exposure Guidelines.

Co-location

This transmitter must not be co-located or operated in conjunction with any other antenna or transmitter.

2.7 Anatel notice

Resolution 680:

This equipment cannot be protected against harmful interference and must not cause interference in duly authorised systems.

Resolution 715:

For further information, please visit the ANATEL website - www.anatel.gov.br

2.8 IFT notice

Operation of this equipment is subject to the following two conditions: (1) this equipment or instrument must not cause harmful interference, and (2) this equipment or instrument must accept any interference, including interference that may cause undesired operation.

2.9 Japanese radio law notice:

当該機器には電波法に基づく、技術基準適合証明等を受けた特定無線設備を装着している。

3. Data transmission security

3. Data transmission security

3.1 Bluetooth® Low Energy

Bluetooth® Low Energy communicates in the licence-free 2.4 GHz ISM band and is a globally harmonised energy efficient radio standard.

Bluetooth® Low Energy uses 40 channels between 2.402 GHz and 2.480 GHz.

Encryption is performed using the AES 128 encryption algorithm in combination with distributed key replacement. The instrument transmits the measured pressure and temperature value as an optional broadcast message on the advertising channels 37, 38 and 39, in addition to the instrument name and the battery charge status. Further information and detailed configuration and command options are available via a point-to-point connection.

Pairing is established using a passkey entry method and requires the entry of a security code.



Pairing is established using a passkey entry method and requires the entry of a security code. Instrument settings can only be accessed after pairing has been completed. The pairing key for each instrument is random. The initial pairing key can be found on the enclosed quick start guide.

If the security code is entered incorrectly 5 times, the instrument is blocked for connection with this code. After disconnecting the voltage supply or removing the battery, 5 attempts are once again available. If this is not possible for technical reasons, e.g. because the sensor cannot be reached to open the case, contact technical support.

3. Data transmission security

3.2 Contents of the QR code on the product label (example)



BT:D0:E526EA6D495E:S1A01N14MPIG:C9657

Contents	Identifier	Example	Comment
Preface	-	BT	Technology identifier
SchemalD	-	D0	-
MAC	-	E526EA6D495E	BT MAC address: E5:26:EA:6D:49:5E
SerNum	S	S1A01N14MPIG	Alphanumeric WIKA serial number (11-digit)
Checksum	C	9657	-

EN

4. Information on wireless transmission

4. Information on wireless transmission







4.1 Bluetooth®

EN

Frequency band	Transmission power	Model
ISM band: 2.4 GHz	+4 dBm / 2.51 mW	NETRIS®1
		NETRIS®F
		PEW-1000
		TRW
		CPG1500
		CPH7000
		GDI-100-D
		CPG1200
	+5.2 dBm / 3.31 mW	

5. Approvals

5. Approvals

Logo	Description	Region
	<p>EU declaration of conformity</p> <p>RED - Radio Equipment Directive EN 300 328 harmonised frequency band ISM 2.4 GHz is used; Bluetooth® Classic, max. transmission power 10 mW. The instrument may be used without restrictions in the EU and in the countries of the EFTA.</p>	European Union
	<p>Radio Law Japan</p> <p>Radio approval</p>	Japan
	<p>Federal Communications Commission (FCC) for US</p> <p>Radio approval → If there is a clear identifier (example: „FCC ID: EXAMPLEID“ or „IC: 12345-ABCDE“) on its product label, the instrument has a valid radio approval for the USA. The FCC logo stands for compliance with the EMC regulations of the USA.</p>	USA
-	<p>Innovation, Science and Economic Development (ISED) for Canada</p> <p>Radio approval → If the text "Contains IC: X8WBC805M" is on its product label, the instrument has a valid radio approval for Canada.</p>	Canada
-	<p>ICASA (Independent Communications Authority of South Africa)</p> <p>Radio certification</p>	South Africa
	<p>Radiocommunications Equipment Rules</p> <p>Radio approval Australia - ABN 49 004 465 936 New Zealand - company no. 400909</p>	Australia and New Zealand
	<p>IFT Instituto Federal de Telecomunicaciones</p> <p>Radio approval</p>	Mexico
	<p>Agência Nacional de Telecomunicações</p> <p>Radio approval</p>	Brazil



Some approvals are only available on request. For further information on the radio approvals, see www.wika.com.



Inhalt

1. Allgemeines	18
2. Sicherheit	21
3. Datenübertragungssicherheit	27
4. Hinweise zur Funkübertragung	29
5. Zulassungen	30

DE

Konformitätserklärungen finden Sie online unter www.wika.de.

1. Allgemeines

Ergänzende Dokumentation:

- ▶ Bitte alle im Lieferumfang enthaltenen Dokumente beachten.



Vor der Inbetriebnahme des Geräts ist zusätzlich die Betriebsanleitung des jeweiligen Geräts zu beachten.

1. Allgemeines

- Das in der Betriebsanleitung beschriebene Gerät wird nach dem aktuellen Stand der Technik konstruiert und gefertigt. Alle Bauteile unterliegen während der Herstellung strengen Qualitäts- und Umweltkriterien. Unsere Managementsysteme sind nach ISO 9001 und ISO 14001 zertifiziert.
- Diese Betriebsanleitung gibt wichtige Hinweise zum Umgang mit dem Gerät. Voraussetzung für sicheres Arbeiten ist die Einhaltung aller angegebenen Sicherheitshinweise und Handlungsanweisungen.
- Die für den Einsatzbereich des Geräts geltenden örtlichen Unfallverhütungsvorschriften und allgemeinen Sicherheitsbestimmungen einhalten.
- Die Betriebsanleitung ist Produktbestandteil und muss in unmittelbarer Nähe des Geräts für das Fachpersonal jederzeit zugänglich aufbewahrt werden. Betriebsanleitung an nachfolgende Bediener oder Besitzer des Geräts weitergeben.
- Das Fachpersonal muss die Betriebsanleitung vor Beginn aller Arbeiten sorgfältig durchgelesen und verstanden haben.
- Bei unterschiedlicher Auslegung der übersetzten und der englischen Betriebsanleitung ist der englische Wortlaut maßgebend.
- In diesem Dokument wird zur besseren Lesbarkeit das generische Maskulinum verwendet. Weibliche und anderweitige Geschlechteridentitäten werden dabei ausdrücklich eingeschlossen.
- Falls vorhanden, gilt neben dieser Betriebsanleitung auch die mitgelieferte Zuliefererdokumentation als Produktbestandteil.
- Es gelten die allgemeinen Geschäftsbedingungen in den Verkaufsunterlagen.
- Technische Änderungen vorbehalten.

Weitere Informationen:

- Internet-Adresse:
- Kontakt:

www.wika.de / www.wika.com

Tel.: +49 9372 132-0

info@wika.de

1. Allgemeines

Typ	FCC Klasse	FCC ID	IC ID	ANATEL	Japan TELEC	CMIIT ID	Datenblatt
NETRIS®1	B	Contains FCC ID: HSW2832	Contains IC ID: 4492A-2832	-	-	-	AC 40.01
NETRIS®F	B	Contains FCC ID: HSW2832	Contains IC ID: 4492A-2832	-	-	-	AC 40.10
PEW-1000	B	Contains FCC ID: HSW2832	Contains IC ID: 4492A-2832	-	-	-	PE 87.23
TRW	B	Contains FCC ID: HSW2832	Contains IC ID: 4492A-2832	-	-	-	TE 63.04
CPG1200	B	Contains FCC ID: X8WBC805M	Contains IC: 4100A-BC805M	02700-24-16462	Contains ID: 201-200778/00	-	CT 10.20
CPG1500	-	contains FCC ID: T7VPAN10	contains IC: 216Q-PAN10	-	017-190033	24J99453V910	CT 10.51
CPH7000	B	Contains FCC ID: T7V1316	Contains IC ID: 216Q-1316	-	-	-	CT 15.51
GDI-100-D	B	Contains FCC ID: T7VPAN10	Contains IC ID: 216Q-PAN10	-	017-190033	-	SP 60.07

DE

1. Allgemeines

1.1 Abkürzungen, Definitionen

- Aufzählungssymbol
- ▶ Handlungsanweisung
- 1. ... x. Handlungsanweisung Schritt für Schritt durchführen
- Siehe ... Querverweise
- FCC ID Eindeutige Kennung der Federal Communications Commission (FCC)

1.2 Symbol- und Begriffserklärung



Hinweis

... hebt nützliche Tipps und Empfehlungen sowie Informationen für einen effizienten und störungsfreien Betrieb hervor.

2. Sicherheit

2. Sicherheit

2.1 Bestimmungsgemäße Verwendung

Die WIKA-Lösungen stellen Messwerte und andere Funktionen je nach Gerät und Spezifikation in verschiedenen Industrien und Ländern bzw. Regionen per Bluetooth bereit. Aufgrund der verschiedenen Ländern bzw. Regionen ergeben sich Unterschiede zu den einzelnen Funkzulassungen, Frequenzbänder und deren Sendeleistungen. Bei der Wahl des Landes bzw. der Region wird vorausgesetzt, dass der Nutzer das ausgewählte Frequenzband auf entsprechende Eignung im Bezug auf die jeweiligen Vorschriften und Zulassungen geprüft hat, um Funkstörung und Verstöße zu verhindern.

Das Gerät ist ausschließlich für die hier beschriebene bestimmungsgemäße Verwendung konzipiert und konstruiert und darf nur dementsprechend verwendet werden.

Die technischen Spezifikationen der jeweiligen Geräte sind einzuhalten, siehe Betriebsanleitung des jeweiligen Geräts. Eine sachgemäße Handhabung und das Betreiben des Geräts innerhalb der technischen Spezifikationen wird vorausgesetzt. Andernfalls ist eine sofortige Stilllegung und Überprüfung durch einen autorisierten WIKA-Servicemitarbeiter erforderlich.

Ansprüche jeglicher Art aufgrund von nicht bestimmungsgemäßer Verwendung sind ausgeschlossen.

2.2 Fehlgebrauch

Jede über die bestimmungsgemäße Verwendung hinausgehende oder andersartige Benutzung gilt als Fehlgebrauch, siehe Betriebsanleitung des jeweiligen Geräts.

DE

2. Sicherheit

2.3 Beschilderung, Sicherheitskennzeichnungen (Beispiel)

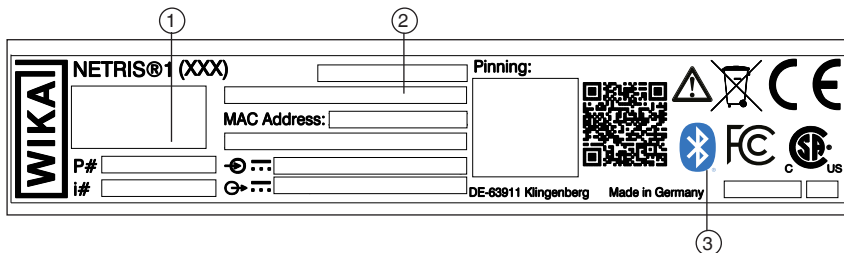

- ① Funkstandard
- ② MAC-Adresse
- ③ Logo Funkstandard

2.4 Anforderungen für Funkübertragung



Die Verwendung der Funkeinheit unterliegt den Regelungen und Bestimmungen des jeweiligen Einsatzlands. Das Modul darf nur in den Ländern eingesetzt werden, für die eine Länderzertifizierung vorliegt. Die Ausfuhr in Länder, für die das Produkt keine Zulassung besitzt, ist nicht gestattet.

2. Sicherheit



Mit dieser Version der Betriebsanleitung ist das Gerät in den folgenden Ländern zum Betrieb zugelassen:

EU-Länder

Belgien, Bulgarien, Dänemark, Deutschland, Estland, Finnland, Frankreich, Griechenland, Irland, Italien, Kroatien, Lettland, Litauen, Luxemburg, Malta, die Niederlande, Österreich, Polen, Portugal, Rumänien, Schweden, die Slowakei, Slowenien, Spanien, die Tschechische Republik, Ungarn und Zypern

EFTA-Länder

Island, Liechtenstein, Norwegen und Schweiz

Weitere Länder

Vereinigtes Königreich UK

Weitere Länder auf Anfrage verfügbar. Weitere ausführliche Informationen zu den Funkzulassungen siehe www.wika.de oder Datenblatt des jeweiligen Geräts.

Geräte mit FCC/ISED-Kennzeichnung sind zusätzlich für USA und Kanada zugelassen.

Wenn auf dem Typenschild eine eindeutige Kennung (Beispiel: „Contains FCC ID: EXAMPLEID“ oder „IC ID:EXAMPLEID“) vorhanden ist, verfügt das Gerät über eine gültige Funkzulassung für die USA und Kanada. Für die eindeutige Zulassungs-ID je Gerät, siehe Kapitel [1 „Allgemeines“](#). Das FCC-Logo steht für die Einhaltung der EMV-Regulieren der USA.



Falls ein Land nicht in der Liste aufgeführt ist, sollten Informationen zur Verwendung von WIKA-Produkten in bei der WIKA-Niederlassung eingeholt werden.

Eine Nutzung in anderen Ländern ist nicht gestattet, siehe Kapitel [5 „Zulassungen“](#).

DE

2. Sicherheit

2.5 IC-Hinweis

IC-Warnhinweise RSS-Gen & Erklärung RSS-247

Dieses Gerät erfüllt die Anforderungen der Radio Standards Specification (RSS) von Industry Canada an lizenzfreie Funkgeräte.

Der Betrieb unterliegt den beiden folgenden Bedingungen:

1. Das Gerät darf keine Störungen erzeugen.
2. Der Benutzer des Geräts muss alle auftretenden Funkstörungen vertragen, einschließlich Störungen, die einen unerwünschten Betrieb verursachen können.

Achtung

Strahlenbelastung bei Funkfrequenzen:

Dieses Gerät entspricht den IC-Grenzwerten für Strahlenbelastung in einer unkontrollierten Umgebung und erfüllt die Richtlinien hinsichtlich der Belastung bei Funkfrequenzen (RF) gemäß IC.

Co-Location

Dieser Transmitter darf nicht in Verbindung mit einer anderen Antenne oder einem anderen Transmitter aufgestellt oder betrieben werden, unabhängig von dessen Typ.

2.6 FCC-Hinweise

Informationen von der FCC (Federal Communications Commission)

FCC-Warnhinweis, Klasse A

Dieses Gerät wurde einer Überprüfung unterzogen und erfüllt nachweislich die Grenzwerte für ein Digitalgerät der Klasse A gemäß Teil 15 der FCC-Vorschriften. Die Grenzwerte sollen einen angemessenen Schutz vor schädlichen Störungen bieten, wenn die Geräte im gewerblichen Rahmen betrieben werden. Dieses Gerät erzeugt und benutzt hochfrequente Energien und kann diese abstrahlen. Wenn es nicht in Übereinstimmung mit den Handlungsanweisungen in dieser Bedienungsanleitung installiert und verwendet wird, kann es den Rundfunkempfang erheblich beeinträchtigen.

Bei Betrieb dieses Geräts in einem Wohngebiet ist mit Störungen zu rechnen, bei deren Vorliegen der Bediener diese auf eigene Kosten beheben muss.

2. Sicherheit

FCC-Warnhinweis, Klasse B

Dieses Gerät wurde einer Überprüfung unterzogen und erfüllt nachweislich die Grenzwerte für ein Digitalgerät der Klasse B nach Teil 15 der FCC-Vorschriften. Diese Grenzwerte sollen einen angemessenen Schutz gegen Störungen bei Installation in einem Wohngebiet garantieren. Dieses Gerät erzeugt, nutzt und strahlt Energie in Form von Funkfrequenzen ab, die bei Installation und Verwendung unter Nichtbeachtung der Anleitung zu schädlichen Störungen in der Funkkommunikation führen können. Es gibt jedoch keine Garantie dafür, dass es bei bestimmten Installationen nicht doch zu Störungen kommt. Wenn dieses Gerät Störungen des Rundfunk- und Fernsehempfangs verursacht, was durch Aus- und Einschalten des Geräts festgestellt werden kann, sollte der Benutzer versuchen, die Störung durch eine oder mehrere der folgenden Maßnahmen zu beheben:

- Die Empfängerantenne an einer anderen Stelle platzieren bzw. diese neu ausrichten.
- Den Abstand zwischen dem Gerät und dem Empfänger vergrößern.
- Das Gerät an einen Stromkreis anschließen, den der Empfänger nicht benutzt.
- An den Händler oder einen erfahrenen Rundfunk-/TV-Techniker wenden.

Ansprüche jeglicher Art aufgrund von nicht bestimmungsgemäßer Verwendung sind ausgeschlossen.

Bei diesem Produkt handelt es sich um ein FCC-zugelassenes Gerät. Umbauten am Gerät führen zu einem sofortigen Stillsetzen des Geräts.

Zur eingenen Sicherheit

Für eine Composite-Schnittstelle sollten geschirmte Kabel verwendet werden. Damit soll ein kontinuierlicher Schutz vor Funkstörungen gewährleistet werden.

Vorsicht

Veränderungen oder Modifikationen, die nicht ausdrücklich durch die für die Konformität zuständige Stelle genehmigt sind, könnten die Berechtigung des Benutzers zum Betreiben des Geräts ungültig machen. Um die Emissionsgrenzen einhalten zu können, müssen geschirmte Kabel verwendet werden.

FCC-Hinweis

Dieses Gerät erfüllt Teil 15 der FCC-Vorschriften.

Der Betrieb unterliegt den beiden folgenden Bedingungen:

1. Dieses Gerät darf keine schädlichen Störungen verursachen.
2. Dieses Gerät muss alle empfangenen Störungen vertragen, einschließlich Störungen, die einen unerwünschten Betrieb verursachen können.

2. Sicherheit

Vorsicht Strahlenbelastung bei Funkfrequenzen

Dieses Gerät entspricht den FCC-Grenzwerten für Strahlenbelastung in einer unkontrollierten Umgebung und erfüllt die Richtlinien hinsichtlich der Belastung bei Funkfrequenzen gemäß FCC.

Co-Location

Dieser Transmitter darf nicht in Verbindung mit einer anderen Antenne oder einem anderen Transmitter aufgestellt oder betrieben werden

2.7 Anatel notice

Resolution 680:

This equipment cannot be protected against harmful interference and must not cause interference in duly authorised systems.

Resolution 715:

For further information, please visit the ANATEL website - www.anatel.gov.br

2.8 IFT notice

Operation of this equipment is subject to the following two conditions: (1) this equipment or instrument must not cause harmful interference, and (2) this equipment or instrument must accept any interference, including interference that may cause undesired operation.

2.9 Japanese radio law notice:

当該機器には電波法に基づく、技術基準適合証明等を受けた特定無線設備を装着している。

3. Datenübertragunsicherheit

3. Datenübertragungssicherheit

3.1 Bluetooth® Low Energy

Bluetooth® Low Energy kommuniziert im lizenzfreien 2,4 GHz ISM-Band und ist ein global einheitlicher energieeffizienter Funkstandard. Bluetooth® Low Energy verwendet 40 Kanäle zwischen 2,402 GHz und 2,480 GHz. Die Verschlüsselung erfolgt mithilfe des AES-128-Encryption-Algorithmus in Kombination mit einer verteilten Schlüsselauswechslung. Das Gerät überträgt als Broadcast Message auf den Advertising-Kanälen 37, 38 und 39 neben dem Gerätenamen und dem Batterieladezustand optional den Druck- und Temperaturmesswert. Über eine Punkt-zu-Punkt-Verbindung stehen weitere Informationen und ausführliche Konfigurations- und Befehlsmöglichkeiten zur Verfügung. Das Pairing wird über eine Passkey-Entry-Methode hergestellt und verlangt die Eingabe eines Sicherheitscodes.



Das Pairing wird über eine Passkey-Entry-Methode hergestellt und verlangt die Eingabe eines Sicherheitscodes. Erst nach erfolgtem Pairing kann auf Geräte-Einstellungen zugegriffen werden. Der Pairing Key ist für jedes Gerät zufällig. Der initiale Pairing Key ist auf dem beiliegenden Quick-Start-Guide zu finden.

Wird der Sicherheitscode 5-mal falsch eingegeben, ist das Gerät für die Verbindung mit diesem Code gesperrt. Nach einem Trennen der Spannungsversorgung bzw. dem Entnehmen der Batterie sind wieder 5 Versuche verfügbar. Sollte das aus technischen Gründen nicht möglich sein, da z. B. der Sensor zum Öffnen des Gehäuses nicht erreichbar ist, den Technischen Support kontaktieren.

DE

3. Datenübertragunsicherheit

3.2 Inhalt des QR-Codes auf dem Typenschild (Beispiel)



BT:D0:E526EA6D495E:S1A01N14MPIG:C9657

Inhalt	Identifizier	Beispiel	Kommentar
Preface	-	BT	Identifizier der Technologie
SchemalD	-	D0	-
MAC	-	E526EA6D495E	BT MAC Adresse: E5:26:EA:6D:49:5E
SerNum	S	S1A01N14MPIG	Alphanumerische WIKA-Seriennummer (11-stellig)
Checksum	C	9657	-

4. Hinweise zur Funkübertragung

4. Hinweise zur Funkübertragung







4.1 Bluetooth®

Frequenzband	Sendeleistung	Typ
ISM-Band: 2,4 GHz	+4 dBm / 2,51 mW	NETRIS®1
		NETRIS®F
		PEW-1000
		TRW
		CPG1500
		CPH7000
		GDI-100-D
	+5,2 dBm / 3,31 mW	CPG1200

DE

5. Zulassungen

5. Zulassungen

Logo	Beschreibung	Region
	EU-Konformitätserklärung RED - Funkanlagenrichtlinie EN 300 328, harmonisierter Frequenzband ISM 2.4 GHz wird verwendet; Bluetooth® Classic, max. Sendeleistung 10 mW. Das Gerät darf ohne Einschränkungen in der EU sowie in den Ländern der EFTA eingesetzt werden.	Europäische Union
	Radio Law Japan Funkzulassung	Japan
	Federal Communications Commission (FCC) for US Funkzulassung → Wenn auf dem Typenschild eine eindeutige Kennung (Beispiel: „FCC-ID: EXAMP-LEID“) vorhanden ist, hat das Gerät eine gültige Funkzulassung für die USA. → Das FCC-Logo steht für die Einhaltung der EMV-Regularien der USA.	USA
-	Innovation, Science, and Economic Development (ISED) for Canada Funkzulassung → Befindet sich der Text „Contains IC: X8WBC805M“ auf ihrem Typenschild, besitzt das Gerät eine gültige Funkzulassung für Kanada.	Kanada
-	ICASA (Independent Communications Authority of South Africa) Funkzertifizierung	Südafrika
	Radiocommunications Equipment Rules Funkzulassung Australien - ABN 49 004 465 936 Neuseeland - Unternehmens-Nr. 400909	Australien und Neuseeland
	IFT Instituto Federal de Telecomunicaciones Radio approval	Mexico
	Agência Nacional de Telecomunicações Funkzulassung	Brasilien



Einige Zulassungen nur auf Anfrage verfügbar. Weitere ausführliche Informationen zu den Funkzulassungen siehe www.wika.de.

Sommaire

1. Généralités	32
2. Sécurité	35
3. Sécurité de la transmission des données	41
4. Informations sur la transmission sans fil	43
5. Agréments	44

Déclarations de conformité disponibles sur www.wika.fr.

1. Généralités

Documentation supplémentaire :

- ▶ Prière de se conformer à toute la documentation incluse dans le détail de la livraison.



Avant la mise en service de l'instrument, il convient de prendre connaissance du mode d'emploi de l'instrument concerné.

FR

1. Généralités

- L'instrument décrit dans le mode d'emploi est conçu et fabriqué selon les dernières technologies. Tous les composants sont soumis à des critères de qualité et de respect de l'environnement stricts durant la fabrication. Nos systèmes de management sont certifiés selon les normes ISO 9001 et ISO 14001.
- Ce mode d'emploi donne des indications importantes concernant l'utilisation de l'instrument. Il est possible de travailler en toute sécurité avec ce produit en respectant toutes les consignes de sécurité et d'utilisation.
- Respecter les prescriptions locales de prévention contre les accidents et les prescriptions générales de sécurité en vigueur pour le domaine d'application de l'instrument.
- Le mode d'emploi fait partie de l'instrument ; il doit être conservé à proximité immédiate de celui-ci et accessible à tout moment pour le personnel qualifié. Confier le mode d'emploi à l'utilisateur ou au propriétaire ultérieur de l'instrument.
- Le personnel qualifié doit, avant de commencer toute opération, avoir lu soigneusement et compris le mode d'emploi.
- En cas d'interprétation différente de la version traduite et de la version anglaise du mode d'emploi, c'est la version anglaise qui prévaut.
- Le cas échéant, la documentation fournie par le fournisseur est également considérée comme faisant partie du produit, en plus du présent mode d'emploi.
- Les conditions générales de vente mentionnées dans les documents de vente s'appliquent.
- Sous réserve de modifications techniques.

- Pour obtenir d'autres informations :
 - Site Internet : www.wika.fr / www.wika.com
 - Contact : Tél. :+49 9372 132-0
info@wika.fr

1. Généralités

Type	FCC classe	FCC ID	IC ID	ANATEL	Japan TELECOM	CMIIT ID	Fiche technique
NETRIS®1	B	Contains FCC ID: HSW2832	Contains IC ID: 4492A-2832	-	-	-	AC 40.01
NETRIS®F	B	Contains FCC ID: HSW2832	Contains IC ID: 4492A-2832	-	-	-	AC 40.10
PEW-1000	B	Contains FCC ID: HSW2832	Contains IC ID: 4492A-2832	-	-	-	PE 87.23
TRW	B	Contains FCC ID: HSW2832	Contains IC ID: 4492A-2832	-	-	-	TE 63.04
CPG1200	B	Contains FCC ID: X8WBC805M	Contains IC: 4100A-BC805M	02700-24-16462	Contains ID: 201-200778/00	-	CT 10.20
CPG1500	-	contains FCC ID: T7VPAN10	contains IC: 216Q-PAN10	-	017-190033	24J99453V910	CT 10.51
CPH7000	B	Contains FCC ID: T7V1316	Contains IC ID: 216Q-1316	-	-	-	CT 15.51
GDI-100-D	B	Contains FCC ID: T7VPAN10	Contains IC ID: 216Q-PAN10	-	017-190033	-	SP 60.07

FR

1. Généralités

1.1 Abréviations, définitions

- Puce
- ▶ Instructions
- 1. ... x. Suivre les instructions étape par étape
- Voir ... renvois
- FCC ID Identifiant unique de la FCC (Federal Communications Commission)

FR

1.2 Explication des symboles et termes



Information

... met en exergue les conseils et recommandations utiles de même que les informations permettant d'assurer un fonctionnement efficace et normal.

2. Sécurité

2. Sécurité

2.1 Utilisation conforme à l'usage prévu

Les solutions WIKA fournissent des valeurs mesurées et d'autres fonctions dans différentes industries et divers pays ou régions via Bluetooth, en fonction de l'instrument et des spécifications. Les différents pays et régions présentent des disparités en termes d'homologations radio, de bandes de fréquences et de puissance de transmission. Lorsque l'utilisateur sélectionne un pays ou une région, il est censé avoir vérifié l'adéquation de la bande de fréquence sélectionnée au regard des réglementations et homologations applicables afin d'éviter les interférences et les infractions en matière de radiofréquences.

L'instrument est conçu et exécuté exclusivement pour une utilisation conforme à l'usage prévu décrit ici et ne doit être utilisé qu'en conséquence.

Les spécifications techniques des instruments respectifs doivent être respectées, voir le mode d'emploi de l'instrument concerné. Il est présumé que l'instrument est manipulé correctement et dans le respect de ses spécifications techniques. Dans le cas contraire, l'instrument doit être immédiatement mis hors service et inspecté par un technicien WIKA agréé.

Aucune réclamation auprès du fabricant ne peut être recevable en cas d'utilisation non conforme à l'usage prévu.

2.2 Utilisation inappropriée

Toute utilisation différente ou au-delà de l'utilisation prévue est considérée comme inappropriée, voir le mode d'emploi de l'instrument concerné.

FR

2. Sécurité

2.3 Etiquetage, marquages de sécurité (exemple)

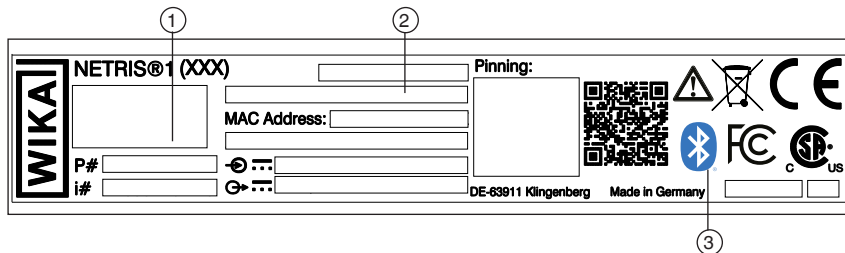

- ① Nome radio
- ② Adresse MAC
- ③ Logo de la norme radio

2.4 Exigences relatives à la transmission sans fil



L'utilisation de l'unité radio est soumise aux conditions et réglementations de chaque pays. Le module peut être utilisé uniquement dans les pays pour lesquels une certification nationale est disponible. Il n'est pas permis d'exporter vers des pays où le produit n'est pas homologué.



Avec cette version du mode d'emploi, l'instrument est homologué pour une utilisation dans les pays suivants :

Pays de l'UE

Belgique, Bulgarie, Danemark, Allemagne, Estonie, Finlande, France, Grèce, Irlande, Italie, Croatie, Lettonie, Lituanie, Luxembourg, Malte, Pays-Bas, Autriche, Pologne, Portugal, Roumanie, Suède, Slovaquie, Slovénie, Espagne, République tchèque, Hongrie et Chypre

Pays de l'AELE

Islande, Liechtenstein, Norvège et Suisse

Autres pays

Royaume-Uni

D'autres pays sont disponibles sur demande. Pour plus d'informations sur les homologations radio, voir www.wika.fr ou la fiche technique de l'instrument concerné.

Les instruments portant le marquage FCC/ISED sont également autorisés aux Etats-Unis et au Canada.

Lorsqu'un identifiant unique (exemple : "Contains FCC ID : EXAMPLEID" ou "IC ID : EXAMPLEID") figure sur la plaque signalétique, l'instrument dispose d'une homologation radio valide pour les Etats-Unis et le Canada. L'identifiant d'homologation unique pour chaque instrument, voir chapitre "[1. Généralités](#)".

Le logo FCC indique que l'instrument est conforme aux réglementations CEM des Etats-Unis.



Si un pays ne figure pas dans la liste, des informations relatives à l'utilisation des produits WIKA doivent être obtenues auprès de la filiale WIKA.

L'utilisation dans d'autres pays n'est pas autorisée, voir chapitre "[5. Agréments](#)".

2. Sécurité

2.5 Notice FC

Déclaration d'avertissements de l'Industrie Canada CNR-Gen et CNR-24

Le présent appareil est conforme aux CNR d'Industrie Canada applicables aux appareils radio exempts de licence.

L'exploitation est autorisée aux deux conditions suivantes:

1. l'appareil ne doit pas produire de brouillage, et
2. l'utilisateur de l'appareil doit accepter tout brouillage radioélectrique subi, même si le brouillage est susceptible d'en compromettre le fonctionnement.

FR

Attention

Exposition au rayonnement de radiofréquences:

Cet équipement est conforme aux limites d'exposition aux radiofréquences IC fixées pour un environnement non contrôlé et aux Lignes directrices relatives à l'exposition aux radiofréquences (RF).

Colocation

Ce transmetteur ne peut pas être installé en colocation ou être utilisé avec une autre antenne ou transmetteur, quel qu'en soit le type

2.6 Notice FCC

Avertissements de la FCC

Information de la Commission fédérale des communications des États-Unis (FCC)

Déclaration d'avertissement FCC classe A

Cet équipement a été testé et se conforme bien aux limites existant pour un appareil numérique de classe A, relevant de la partie 15 des règles FCC. Ces limites sont prévues pour fournir une protection raisonnable contre des interférences nuisibles lorsque l'équipement est utilisé dans un environnement commercial. Cet équipement génère, utilise et peut rayonner de l'énergie de fréquences radio et, s'il n'est pas installé et utilisé en conformité avec le mode d'emploi, peut causer des interférences nuisibles pour les communications radio.

Faire fonctionner cet équipement dans une zone résidentielle risque de causer des interférences nuisibles, et dans ce cas l'utilisateur devra corriger les interférences à ses frais.

2. Sécurité

Déclaration d'avertissement FCC classe B

Cet équipement a été testé et se conforme bien aux limites existant pour un appareil numérique de classe B, relevant de la Partie 15 des règles FCC. These limits are designed to provide reasonable protection against harmful interference in a residential installation. This equipment generates, uses and can radiate radio frequency energy and, if not installed and used in accordance with the instructions, may cause harmful interference to radio communications. However, there is no guarantee that interference will not occur in a particular installation. Si cet équipement provoque des interférences nuisibles à la réception radio ou télévision, ce qui peut être déterminé en allumant et en éteignant l'équipement, l'utilisateur est encouragé à essayer de corriger les interférences en prenant une ou plusieurs des mesures suivantes :

- Réorienter ou déplacer l'antenne de réception.
- Augmenter la distance entre l'appareil et le récepteur.
- Brancher l'équipement sur une prise de courant située sur un circuit différent de celui sur lequel le récepteur est branché.
- Contacter le revendeur ou un technicien radio/TV expérimenté pour obtenir de l'aide.

Aucune réclamation auprès du fabricant ne peut être recevable en cas d'utilisation non conforme à l'usage prévu.

Ce produit est un instrument approuvé FCC. Les modifications apportées à l'instrument entraînent son arrêt immédiat.

Pour votre sécurité

Des câbles blindés doivent être utilisés pour une interface composite. Cela permet d'assurer une protection continue contre les brouillages de radiofréquences.

Caution

Les changements ou modifications non expressément approuvés par la partie responsable de la conformité peuvent annuler le droit d'utilisation de l'équipement par l'utilisateur. Un câble d'interface blindé doit être utilisé pour respecter les limites d'émission.

Notice FCC

Cet appareil satisfait à la section 15 de la réglementation FCC.

L'exploitation est autorisée aux deux conditions suivantes:

1. L'appareil ne doit pas produire de brouillage nuisible.
2. L'appareil doit accepter tout brouillage radioélectrique subi, même si le brouillage est susceptible de compromettre le fonctionnement.

2. Sécurité

Caution

Mise en garde à l'exposition aux radiofréquences

Cet équipement est conforme aux limites d'exposition aux rayonnements de la FCC pour un environnement non contrôlé et respecte les directives d'exposition aux radiofréquences (RF) de la FCC.

Colocation

Ce transmetteur ne peut pas être installé en colocation ou être utilisé avec une autre antenne ou transmetteur, quel qu'en soit le type.

FR

2.7 Anatel notice

Résolution 680:

Cet équipement ne peut faire l'objet d'une protection contre les interférences nuisibles et ne doit pas causer d'interférences dans les systèmes dûment autorisés.

Résolution 715:

Pour plus d'informations, visitez le Internet d'ANATEL - www.anatel.gov.br

2.8 IFT notice

Le fonctionnement de cet appareil est autorisé aux deux conditions suivantes : (1) l'appareil ne doit pas produire de brouillage nuisible et (2) l'appareil doit accepter tout brouillage radioélectrique, même si le brouillage est susceptible de compromettre le fonctionnement.

2.9 Notice de la loi radio japonaise :

当該機器には電波法に基づく、技術基準適合証明等を受けた特定無線設備を装着している。

3. Sécurité de la transmission des données

3. Sécurité de la transmission des données

3.1 Bluetooth® Low Energy

Le Bluetooth® Low Energy communique dans la bande ISM de 2,4 GHz sans licence et constitue une norme radio écoénergétique harmonisée à l'échelle mondiale.

Le Bluetooth® Low Energy utilise 40 canaux entre 2,402 GHz et 2,480 GHz.

Le chiffrement est assuré par l'algorithme de chiffrement AES 128 et par le remplacement de la clé distribuée.

L'instrument transmet les valeurs de pression et de température mesurées en tant que message de diffusion en option sur les canaux de publicité 37, 38 et 39, ainsi que le nom de l'instrument et l'état de charge de la batterie.

Vous trouverez plus d'informations, la configuration détaillée et les options de commande via la connexion point à point.

L'appairage est établi à l'aide d'une méthode de saisie de clé d'accès et nécessite la saisie d'un code de sécurité.



L'appairage est établi à l'aide d'une méthode de saisie de clé d'accès et nécessite la saisie d'un code de sécurité. Les réglages de l'instrument ne sont accessibles qu'une fois l'appairage effectué. La clé d'appairage de chaque instrument est aléatoire. La clé d'appairage initiale se trouve dans le guide de prise en main fourni.

Si vous vous trompez 5 fois dans le code de sécurité, la connexion de l'instrument avec ce code se bloque. Vous disposez de 5 nouvelles tentatives après avoir mis l'instrument hors tension ou retiré la batterie. Si cela est impossible pour des raisons techniques, par exemple parce que vous ne pouvez pas accéder au capteur pour ouvrir le boîtier, contacter l'assistance technique.

FR

3. Sécurité de la transmission des données

3.2 Contenu du code QR sur la plaque signalétique (exemple)



BT:D0:E526EA6D495E:S1A01N14MPIG:C9657

FR

Sommaire	Identifiant	Exemple	Commentaire
Préface	-	BT	Identifiant technologique
SchemalD	-	D0	-
MAC	-	E526EA6D495E	Adresse MAC BT : E5:26:EA:6D:49:5E
SerNum	S	S1A01N14MPIG	Numéro de série alphanumérique WIKA (11 chiffres)
Checksum	C	9657	-

4. Informations sur la transmission sans fil

4. Informations sur la transmission sans fil







4.1 Bluetooth®

Bande de fréquence	Puissance de transmission	Type
Bande ISM : 2,4 GHz	+4 dBm / 2,51 mW	NETRIS®1
		NETRIS®F
		PEW-1000
		TRW
		CPG1500
		CPH7000
		GDI-100-D
	+5,2 dBm / 3,31 mW	CPG1200

FR

5. Agréments

5. Agréments

Logo	Description	Région
	<p>Déclaration de conformité UE</p> <p>RED - Directive relative aux équipements radio EN 300 328, une gamme de fréquence harmonisée ISM 2,4 GHz est utilisée ; Bluetooth® Classic, transmission maximale de puissance 10 mW. L'instrument peut être utilisé sans restriction dans l'UE et dans les pays de l'AELE.</p>	Union européenne
	<p>Loi radio japonaise Homologation radio</p>	Japon
	<p>FCC (Federal Communications Commission) pour les Etats-Unis Homologation radio → Lorsqu'un identifiant clair (exemple : "FCC ID : EXAMPLEID") figure sur la plaque signalétique, cela signifie que l'instrument dispose d'une homologation radio valide pour les Etats-Unis. → Le logo FCC indique que l'instrument est conforme aux réglementations CEM des Etats-Unis.</p>	USA
-	<p>ISED (Innovation, Science and Economic Development) pour le Canada Homologation radio → Si le texte "Contains IC: X8WBC805M" figure sur la plaque signalétique, l'instrument dispose d'une homologation radio valide pour le Canada.</p>	Canada
-	<p>ICASA (Autorité indépendante des communications d'Afrique du Sud) Certification radio</p>	Afrique du Sud
	<p>Radiocommunications Equipment Rules Homologation radio Australie - ABN 49 004 465 936 Nouvelle-Zélande - n° d'entreprise 400909</p>	Australie et Nouvelle-Zélande
	<p>IFT Instituto Federal de Telecomunicaciones Radio approval</p>	Mexique
	<p>Agência Nacional de Telecomunicações Homologation radio</p>	Brésil



Certaines homologations ne sont disponibles que sur demande. Pour plus d'informations sur les homologations radio, voir le site Internet www.wika.com.

Contenido

1. Información general	46
2. Seguridad	49
3. Seguridad en la transmisión de datos	55
4. Información sobre la transmisión inalámbrica	57
5. Homologaciones	58

ES

Las declaraciones de conformidad se pueden encontrar en www.wika.es.

1. Información general

Documentación complementaria:

- Consulte toda la documentación incluida en el volumen de suministro.



Antes de la puesta en servicio del instrumento, debe tenerse en cuenta el manual de instrucciones del instrumento correspondiente.

1. Información general

ES

- El instrumento descrito en el manual de instrucciones está construido y fabricado según el estado actual de la técnica. Todos los componentes están sometidos durante su fabricación a estrictos criterios de calidad y medio-ambientales. Nuestros sistemas de gestión están certificados según ISO 9001 e ISO 14001.
- Este manual de instrucciones proporciona indicaciones importantes acerca del manejo del instrumento. Para un trabajo seguro, es imprescindible cumplir con todas las instrucciones de seguridad y manejo indicadas.
- Cumplir siempre las normativas sobre la prevención de accidentes y las normas de seguridad en vigor en el lugar de utilización del instrumento.
- El manual de instrucciones es una parte integrante del instrumento y debe guardarse en la proximidad del mismo para que el personal especializado pueda consultarlo en cualquier momento. Entregar el manual de instrucciones al usuario o propietario siguiente del instrumento.
- El personal especializado debe haber leído y entendido el manual de instrucciones antes de comenzar cualquier trabajo.
- En caso de interpretación diferente de las instrucciones de uso traducidas y las inglesas, prevalecerá la redacción inglesa.
- Si está disponible, la documentación suministrada por el proveedor también se considera parte del producto, además de estas instrucciones de uso.
- Se aplican las condiciones generales de venta incluidas en la documentación de venta.
- Modificaciones técnicas reservadas.

- Para obtener más información consultar:
 - Página web: www.wika.es / www.wika.com
 - Contacto: [Tel.: +34 933 9386-30](mailto:info@wika.es)
info@wika.es

1. Información general

Modelo	FCC clase	FCC ID	IC ID	ANATEL	Japan TELECOM	CMIIT ID	Hoja técnica
NETRIS®1	B	Contains FCC ID: HSW2832	Contains IC ID: 4492A-2832	-	-	-	AC 40.01
NETRIS®F	B	Contains FCC ID: HSW2832	Contains IC ID: 4492A-2832	-	-	-	AC 40.10
PEW-1000	B	Contains FCC ID: HSW2832	Contains IC ID: 4492A-2832	-	-	-	PE 87.23
TRW	B	Contains FCC ID: HSW2832	Contains IC ID: 4492A-2832	-	-	-	TE 63.04
CPG1200	B	Contains FCC ID: X8WBC805M	Contains IC: 4100A-BC805M	02700-24-16462	Contains ID: 201-200778/00	-	CT 10.20
CPG1500	-	contains FCC ID: T7VPAN10	contains IC: 216Q-PAN10	-	017-190033	24J99453V910	CT 10.51
CPH7000	B	Contains FCC ID: T7V1316	Contains IC ID: 216Q-1316	-	-	-	CT 15.51
GDI-100-D	B	Contains FCC ID: T7VPAN10	Contains IC ID: 216Q-PAN10	-	017-190033	-	SP 60.07

ES

1. Información general

1.1 Abreviaturas, definiciones

- Símbolo de enumeración
- ▶ Instrucción
- 1. ... x. Seguir las instrucciones paso a paso
- Ver ... referencias cruzadas
- FCC ID Identificador único de la Comisión Federal de Comunicaciones (FCC)

1.2 Explicación de símbolos y términos

ES



Información

... destaca consejos y recomendaciones útiles así como informaciones para una utilización eficiente y libre de errores.

2. Seguridad

2. Seguridad

2.1 Uso conforme a lo previsto

Las soluciones WIKA proporcionan valores medidos y otras funciones en diferentes industrias y países o regiones a través de Bluetooth, dependiendo del instrumento y la especificación. Debido a los distintos países y regiones, existen diferencias en las homologaciones individuales de radio, las bandas de frecuencia y su potencia de transmisión. Al seleccionar el país o la región, se presupone que el usuario ha comprobado la idoneidad de la banda de frecuencias seleccionada con respecto a las normativas y homologaciones pertinentes para evitar interferencias e infracciones de radiofrecuencia.

El instrumento ha sido diseñado y construido únicamente para la finalidad aquí descrita y debe utilizarse en conformidad a la misma.

Deben observarse las especificaciones técnicas de los respectivos instrumentos, véanse los manuales de instrucciones de los mismos. Se supone que el instrumento se manipula correctamente y dentro de sus especificaciones técnicas. En caso contrario, el aparato debe ponerse fuera de servicio inmediatamente y ser inspeccionado por un técnico autorizado de WIKA.

No se admite ninguna reclamación debido a un manejo no adecuado.

2.2 Uso incorrecto

Cualquier uso que exceda o difiera del uso previsto se considera un uso inadecuado. Consulte el manual de instrucciones de cada instrumento.

ES

2. Seguridad

2.3 Rótulos, marcajes de seguridad (ejemplo)

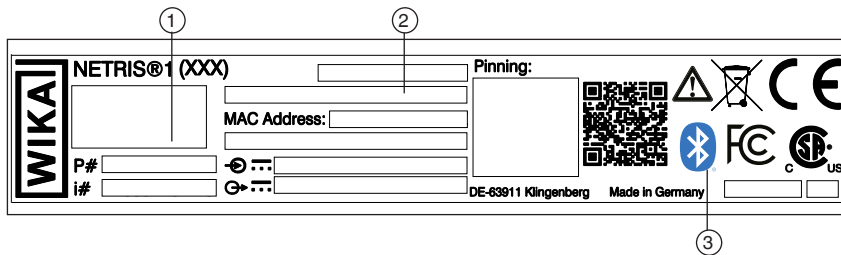

- 1 Estándar de radio
- 2 Dirección MAC
- 3 Logo de estándar de radio

2.4 Requisitos para la transmisión inalámbrica



La utilización del módulo de radio está sujeto a las normas y reglamentos del respectivo país. El módulo sólo debe utilizarse en los países para los que se dispone de una certificación nacional. No está permitida la exportación a países para los que el producto no esté homologado.

2. Seguridad



Con esta versión del manual de instrucciones, el producto está autorizado para su uso en los siguientes países:

Países de la UE

Bélgica, Bulgaria, Dinamarca, Alemania, Estonia, Finlandia, Francia, Grecia, Irlanda, Italia, Croacia, Letonia, Lituania, Luxemburgo, Malta, Países Bajos, Austria, Polonia, Portugal, Rumanía, Suecia, Eslovaquia, Eslovenia, España, República Checa, Hungría y Chipre

Países de la AELC

Islandia, Liechtenstein, Noruega y Suiza

Otros países

Reino Unido UK

Otros países disponibles previa solicitud. Para más información sobre los protocolos de radio, consulte www.wika.es o la hoja técnica del instrumento correspondiente.

Los dispositivos con marca FCC/ISED también están aprobados para Estados Unidos y Canadá. Si en la etiqueta del producto figura un identificador único (por ejemplo: „Contiene FCC ID: EXAMP-LEID“ o „IC ID:EXAMPLEID“), el instrumento cuenta con una homologación de radio válida para EE.UU. y Canadá. El identificador único de aprobación de cada instrumento, véase capítulo [“1. Généralités”](#).

El logotipo de la FCC indica el cumplimiento de la normativa sobre compatibilidad electromagnética de Estados Unidos.



Si un país no está incluido en la lista, deberá obtenerse información sobre el uso de los productos WIKA en la correspondiente filial de WIKA.

No está permitido su uso en otros países, véase el capítulo [“5. Homologaciones”](#).

ES

2. Seguridad

2.5 Aviso IC

Advertencias IC Declaración RSS-Gen & RSS-247

Este dispositivo cumple con las normas CNR de Industria Canadá aplicables a los dispositivos de radio que no requieren licencia

La operación está permitida bajo las siguientes dos condiciones:

1. El dispositivo no debe generar interferencias y
2. El usuario del dispositivo debe aceptar cualquier interferencia radioeléctrica recibida, incluso si esta puede afectar su funcionamiento.

ES

Atención

Exposición a la radiación de radiofrecuencias:

Este equipo cumple con los límites de exposición a radiofrecuencias establecidos por IC para un entorno no controlado y con las Directrices sobre exposición a radiofrecuencias (RF).

Instalación

Este transmisor no puede ser instalado ni utilizado junto a otra antena o transmisor, sea cual sea su modelo.

2.6 Advertencias de la FCC

Información de la FCC (Comisión Federal de Comunicaciones)

Declaración de advertencia FCC clase A

El instrumento ha sido probado y cumple con los límites de un instrumento digital de clase A de acuerdo con la Parte 15 de las Reglas de la FCC. Los valores límite están diseñados con la protección adecuada contra interferencias perjudiciales cuando se utiliza el instrumento en un entorno comercial. El instrumento genera o utiliza energía de alta frecuencia y la irradia. El incumplimiento de las indicaciones de este manual de instrucciones puede provocar interferencias perjudiciales en la comunicación por radio.

El funcionamiento de este equipo en una zona residencial puede causar interferencias perjudiciales, en cuyo caso el usuario deberá corregir las interferencias a su cargo.

2. Seguridad

Declaración de advertencia FCC clase B

Este equipo ha sido probado y se ha comprobado que cumple con los límites de un dispositivo digital de clase A, de conformidad con la parte 15 de las normas de la FCC. Los valores límites apuntan a garantizar una adecuada protección contra interferencias si se instala en una zona residencial. Este equipo genera, utiliza y emite energía en forma de frecuencias de radio, lo que, en caso de instalación y uso haciendo caso omiso de las instrucciones, puede provocar interferencias nocivas en las comunicaciones de radio. No obstante, no hay garantía alguna de que en determinadas instalaciones no se produzcan interferencias. Si este equipo causa interferencias perjudiciales en la recepción de radio o televisión, lo que puede determinarse apagando y encendiendo el equipo, se recomienda al usuario que intente corregir la interferencia mediante una o más de las siguientes medidas:

- Reoriente o reubique la antena receptora.
- Aumente la separación entre el equipo y el receptor.
- Conecte el equipo a una toma de corriente de un circuito distinto al que está conectado el receptor.
- Consulte al distribuidor o a un técnico experto en radio/TV para obtener ayuda.

No se admite ninguna reclamación debido a un manejo no adecuado.

Este producto es un instrumento aprobado por la FCC. Si se realizan modificaciones en el instrumento, éste se apaga inmediatamente.

Para su propia seguridad

Deben utilizarse cables blindados para una interfaz compuesta. De este modo se garantiza una protección continua contra las interferencias de radiofrecuencia.

Cuidado

Los cambios o modificaciones no aprobados expresamente por la parte responsable del cumplimiento podrían anular la autoridad del usuario para utilizar el equipo. Debe utilizarse un cable de interfaz apantallado para respetar los límites de emisión.

Aviso FCC

Este instrumento cumple con la parte 15 de las normas FCC.

La operación está supeditada a las siguientes condiciones:

1. Este instrumento no debe provocar interferencia dañinas.
2. Este instrumento debe absorber todas las interferencias recibidas, incluyendo interferencias que pudieran provocar un funcionamiento accidental.

ES

2. Seguridad

Exposición a la radiación de radiofrecuencia

Este equipo cumple con los límites de exposición a la radiación del FCC establecidos para un entorno no controlado y cumple con las Directrices de exposición a radiofrecuencia (RF) del FCC.

Coubicación

Este transmisor no debe colocarse ni utilizarse junto con ninguna otra antena o transmisor.

2.7 Aviso Anatel

Resolución 680:

Este equipo no puede protegerse contra interferencias perjudiciales y no debe causar interferencias en sistemas debidamente autorizados.

Resolución 715:

Para más información, véase el sitio web de ANATEL - www.anatel.gov.br

2.8 Aviso IFT

La operación de este equipo está sujeta a las siguientes dos condiciones: (1) es posible que este equipo o dispositivo no cause interferencia perjudicial y (2) este equipo o dispositivo debe aceptar cualquier interferencia, incluyendo la que pueda causar su operación no deseada.

2.9 Japanese radio law notice:

当該機器には電波法に基づく、技術基準適合証明等を受けた特定無線設備を装着している。

3. Seguridad en la transmisión de datos

3. Seguridad en la transmisión de datos

3.1 Bluetooth® Low Energy

Bluetooth® Low Energy se comunica en la banda ISM de 2,4 GHz, libre de licencia, y es una norma de radio de bajo consumo armonizada a escala mundial.

Bluetooth® Low Energy utiliza 40 canales entre 2,402 GHz y 2,480 GHz.

El cifrado se realiza mediante el algoritmo de cifrado AES 128 en combinación con la sustitución distribuida de claves.

El instrumento transmite el valor de presión y temperatura como mensaje de difusión opcional en los canales de aviso 37, 38 y 39, además del nombre del instrumento y el nivel de carga de la batería.

Puede obtener más información y opciones detalladas de configuración y comandos a través de una conexión punto a punto.

El emparejamiento se establece mediante un método de introducción de claves y requiere la introducción de un código de seguridad.



El emparejamiento se establece mediante un método de introducción de claves y requiere la introducción de un código de seguridad. Sólo se puede acceder a los ajustes del instrumento una vez completado el emparejamiento. La clave de emparejamiento de cada instrumento es aleatoria. La clave de emparejamiento inicial se encuentra en la guía de inicio rápido adjunta.

Si el código de seguridad se introduce incorrectamente 5 veces, el instrumento se bloquea para la conexión con este código. Tras desconectar la alimentación de tensión o retirar la pila, se dispone de nuevo de 5 intentos. Si esto no es posible por razones técnicas, por ejemplo, porque no se puede alcanzar el sensor para abrir la caja, póngase en contacto con el servicio técnico.

3. Seguridad en la transmisión de datos

3.2 Contenido del código QR en la etiqueta del producto (ejemplo)



BT:D0:E526EA6D495E:S1A01N14MPIG:C9657

Contenido	Identificador	Ejemplo	Nota
Prefacio	-	BT	Identificador tecnológico
SchemalD	-	D0	-
MAC	-	E526EA6D495E	Dirección MAC de BT: E5:26:EA:6D:49:5E
SerNum	S	S1A01N14MPIG	Número de serie alfanumérico WIKA (11 dígitos)
Checksum	C	9657	-

4. Información sobre la transmisión inalámbrica

4. Información sobre la transmisión inalámbrica

4.1 Bluetooth®

Banda de frecuencias	Potencia de transmisión	Modelo
Banda ISM: 2,4 GHz	+4 dBm / 2,51 mW	NETRIS®1
		NETRIS®F
		PEW-1000
		TRW
		CPG1500
		CPH7000
		GDI-100-D
	+5,2 dBm / 3,31 mW	CPG1200

ES

5. Homologaciones

5. Homologaciones

Logo	Descripción	Región
	<p>Declaración de conformidad UE</p> <p>RED - Directiva sobre equipos radioeléctricos EN 300 328, se utiliza rango de frecuencia armonizada de 2,4 GHz; Bluetooth® clásico, máx. potencia de transmisión de 10 mW. El instrumento puede utilizarse sin restricciones en la UE y en los países de la AELC.</p>	Unión Europea
	<p>Ley de Radio de Japón</p> <p>Aprobación de la radio</p>	Japón
	<p>Comisión Federal de Comunicaciones (FCC) de EE.UU.</p> <p>Aprobación de la radio</p> <p>→ Si hay un identificador claro (ejemplo: "FCC ID: EXAMPLEID") en su etiqueta de producto, el instrumento tiene una aprobación de radio válida para los EE.UU.</p> <p>→ El logotipo de la FCC indica el cumplimiento de la normativa sobre compatibilidad electromagnética de Estados Unidos.</p>	USA
-	<p>Innovación, Ciencia y Desarrollo Económico (ISED) para Canadá</p> <p>Aprobación de la radio</p> <p>→ Si el texto "Contiene IC: X8WBC805M" figura en la etiqueta del producto, el instrumento dispone de una homologación de radio válida para Canadá.</p>	Canadá
-	<p>ICASA (Autoridad Independiente de Comunicaciones de Sudáfrica)</p> <p>Certificación de radio</p>	Sudáfrica
	<p>Reglamento de equipos de radiocomunicaciones</p> <p>Aprobación de la radio</p> <p>Australia - ABN 49 004 465 936 Nueva Zelanda - número de empresa 400909</p>	Australia y Nueva Zelanda
	<p>IFT Instituto Federal de Telecomunicaciones</p> <p>Radio approval</p>	México
	<p>Agência Nacional de Telecomunicações</p> <p>Aprobación de la radio</p>	Brasil

4. Información sobre la transmisión inalámbrica



Algunas homologaciones sólo están disponibles previa solicitud. Para más información sobre los protocolos de radio, consulte www.wika.es.

ES



Conteúdo

Conteúdo

1. Informações gerais	62
2. Segurança	65
3. Segurança na transmissão de dados	71
4. Informações sobre transmissão sem fio	73
5. Aprovações	74

PT

Declarações de conformidade podem ser encontradas no site www.wika.com.br.

1. Informações gerais

Documentação complementar:

- ▶ Siga toda a documentação incluída no escopo de fornecimento.



Antes de colocar o instrumento em funcionamento, é necessário consultar o manual de instruções do instrumento em questão.

1. Informações gerais

- O instrumento descrito nas instruções de operação foi projetado e fabricado com o uso de tecnologia de ponta. Todos os componentes estão sujeitos a rigorosos critérios de qualidade e ambientais durante a produção. Nossos sistemas de gestão da qualidade são certificados de acordo com as normas ISO 9001 e ISO 14001.
- Estas instruções de operação contém informações importantes relativas à utilização do instrumento. O cumprimento de todas as instruções de segurança e de trabalho é condição essencial para garantir um trabalho seguro.
- Observe atentamente as normas locais de prevenção de acidentes e os regulamentos gerais de segurança apropriados para a faixa de uso deste equipamento.
- As instruções de operação fazem parte do produto, e devem ser mantidas nas imediações, de forma facilmente acessível aos profissionais qualificados. Passe as instruções de operação ao próximo usuário ou proprietário do instrumento.
- Os profissionais qualificados devem ler cuidadosamente as instruções antes de dar início a qualquer trabalho.
- No caso de uma interpretação diferente das instruções de operação traduzidas e em inglês, os termos em inglês devem prevalecer.
- Se disponível, a documentação do fornecedor entregue também deve ser considerada parte do produto, além destas instruções de operação.
- Os termos e condições gerais contidos na documentação de venda devem ser considerados.
- Sujeito a alterações técnicas.

- Para mais informações:

- Página da Internet:

www.wika.com.br / www.wika.com

- Contato:

Tel.: +49 9372 132-0

vendas@wika.com.br

1. Informações gerais

Modelo	FCC Class	FCC ID	IC ID	ANATEL	Japan TELECOM	CMIIT ID	Folha de dados
NETRIS®1	B	Contém FCC ID: HSW2832	Contém IC ID: 4492A-2832	-	-	-	AC 40.01
NETRIS®F	B	Contém FCC ID: HSW2832	Contém IC ID: 4492A-2832	-	-	-	AC 40.10
PEW-1000	B	Contém FCC ID: HSW2832	Contém IC ID: 4492A-2832	-	-	-	PE 87.23
TRW	B	Contém FCC ID: HSW2832	Contém IC ID: 4492A-2832	-	-	-	TE 63.04
CPG1200	B	Contém FCC ID: X8WBC805M	Contém IC: 4100A-BC805M	02700-24-16462	Contém ID: 201-200778/00	-	CT 10.20
CPG1500	-	contém FCC ID: T7VPAN10	contém IC: 216Q-PAN10	-	017-190033	24J99453V910	CT 10.51
CPH7000	B	Contém FCC ID: T7V1316	Contém IC ID: 216Q-1316	-	-	-	CT 15.51
GDI-100-D	B	Contém FCC ID: T7VPAN10	Contém IC ID: 216Q-PAN10	-	017-190033	-	SP 60.07

PT

1. Informações gerais

1.1 Abreviações, definições

- Projétil
- ▶ Instruções
- 1. ... x. Siga as instruções passo a passo
- Veja ... referências cruzadas
- FCC ID Identificador único da Comissão Federal de Comunicações (FCC)

1.2 Explicação de símbolos e termos



Informação

... aponta dicas úteis, recomendações e informações para uma operação eficiente e sem problemas.

PT

2. Segurança

2. Segurança

2.1 Uso previsto

As soluções da WIKA fornecem valores de medição e outras funções em diversos setores e países ou regiões via Bluetooth, dependendo do instrumento e da especificação. Devido às diferenças entre países e regiões, existem diferenças nas aprovações de rádio, nas bandas de frequência e respectiva potência de transmissão. Ao selecionar o país ou a região, presume-se que o usuário tenha verificado se a banda de frequência selecionada está em conformidade com as normas e aprovações aplicáveis, a fim de evitar interferências de radiofrequência e infrações.

O instrumento foi projetado e fabricado exclusivamente para o uso aqui descrito, e só pode ser usado dessa forma.

As especificações técnicas dos respectivos instrumentos devem ser respeitadas; consulte o manual de instruções do respectivo instrumento. Partimos da hipótese de que o instrumento seja manuseado corretamente, dentro de suas especificações técnicas. Caso contrário, o instrumento deverá ser retirado de serviço imediatamente, e inspecionado por um engenheiro especialista autorizado pela WIKA.

O fabricante não se responsabiliza por qualquer reclamação baseada no uso contrário ao pretendido.

2.2 Uso impróprio

Qualquer uso que exceda ou difira da finalidade prevista é considerado uso indevido; consulte as instruções de operação do instrumento em questão.

PT

2. Segurança

2.3 Identificação, marcações de segurança (exemplo)

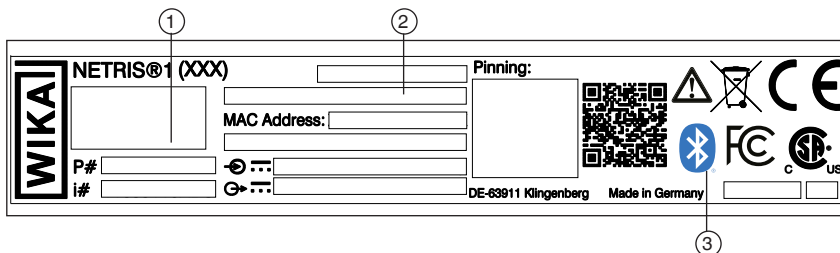

PT

- 1 Padrão de rádio
- 2 Endereço MAC
- 3 Logótipo padrão da rádio

2.4 Requisitos para transmissão sem fio



A utilização do aparelho de rádio está sujeita às disposições e regulamentos do respectivo país. O módulo só pode ser utilizado nos países para os quais existe uma certificação nacional disponível. Não é permitida a exportação para países nos quais o produto não possui aprovação.

2. Segurança



Com esta versão do manual de instruções, o instrumento está aprovado para uso nos seguintes países:

Países da UE

Bélgica, Bulgária, Dinamarca, Alemanha, Estônia, Finlândia, França, Grécia, Irlanda, Itália, Croácia, Letônia, Lituânia, Luxemburgo, Malta, Países Baixos, Áustria, Polónia, Portugal, Romênia, Suécia, Eslováquia, Eslovênia, Espanha, República Tcheca, Hungria e Chipre

Países da EFTA

Islândia, Liechtenstein, Noruega e Suíça

Outros países

Reino Unido

Outros países disponíveis mediante solicitação. Para obter mais informações sobre as aprovações de rádio, consulte www.wika.com ou a ficha técnica do respectivo instrumento.

Os aparelhos com a marcação FCC/ISED também são permitidos nos EUA e no Canadá.

Se um identificador único (exemplo: “Contém FCC ID: EXAMPLEID” ou “IC ID:EXAMPLEID”) estiver presente na etiqueta do produto, o instrumento possui uma aprovação de rádio válida para os EUA e o Canadá. O ID de aprovação único para cada instrumento; consulte o capítulo [“1. Informações gerais”](#).

O logótipo da FCC indica conformidade com as normas de compatibilidade eletromagnética (EMC) dos EUA.



Caso um país não conste da lista, as informações sobre o uso dos produtos WIKA devem ser obtidas junto à filial da WIKA.

O uso em outros países não é permitido; consulte o capítulo [“5. Aprovações”](#).

PT

2. Segurança

2.5 Aviso IC

IC aviso RSS-Gen & RSS-247 statement

Este dispositivo está em conformidade com a(s) norma(s) RSS isentas de licença do Industry Canada.

A operação está sujeita às duas seguintes condições:

1. Este aparelho não deve causar interferências.
2. Este dispositivo deve tolerar qualquer interferência, incluindo aquelas que possam causar um funcionamento indesejado do dispositivo.

Atenção

Exposição à radiação de radiofrequência:

Este equipamento está em conformidade com os limites de exposição à radiação estabelecidos pela IC para ambientes não controlados e cumpre as Diretrizes de Exposição à Radiofrequência (RF) da IC.

PT

Instalação conjunta

Este transmissor não deve ser instalado no mesmo local nem operado em conjunto com qualquer outra antena ou transmissor.

2.6 Aviso FCC

Informações vindas da FCC (Federal Communications Commission)

Declaração de advertência da FCC, classe A

O instrumento foi testado e está em conformidade com os limites estabelecidos para instrumentos digitais da classe A, de acordo com a Parte 15 das Normas da FCC. Os valores-limite foram definidos de modo a garantir proteção adequada contra interferências prejudiciais durante a operação do instrumento em um ambiente comercial. O instrumento gera ou utiliza energia de alta frequência e a irradia. O não cumprimento das instruções contidas neste manual de instruções pode causar interferências prejudiciais na comunicação por rádio.

A utilização deste equipamento em uma área residencial pode causar interferências prejudiciais; nesse caso, o usuário deverá corrigir a interferência às suas próprias custas.

2. Segurança

Declaração de advertência da FCC, classe B

Este instrumento foi testado e está em conformidade com os limites para um instrumento digital classe A, nos termos da parte 15 das regras do FCC. Estes limites são projetadas para prover proteção adequada contra interferências prejudiciais em instalações residenciais. Este equipamento gera, usa, e pode irradiar energias de radiofrequência, e se não for montado e utilizado conforme as instruções, pode causar interferências prejudiciais à comunicação de rádio. Entretanto, não há garantia que a interferência não irá ocorrer em uma instalação particular. Caso este equipamento cause interferência prejudicial à recepção de rádio ou televisão — o que pode ser verificado ligando e desligando o equipamento, recomenda-se ao usuário que tente corrigir a interferência adotando uma ou mais das seguintes medidas:

- Reoriente ou reposicione a antena receptora.
- Aumente a distância entre o equipamento e o receptor.
- Conecte o equipamento a uma tomada em um circuito diferente daquele ao qual o receptor está conectado.
- Consulte o revendedor ou um técnico experiente em rádio e TV para obter ajuda.

O fabricante não se responsabiliza por qualquer reclamação baseada no uso contrário ao pretendido. Este produto é um instrumento aprovado pela FCC. Alterações no instrumento provocam o desligamento imediato do mesmo.

Para sua própria segurança

Devem ser utilizados cabos blindados para uma interface composta. O objetivo é garantir a proteção contínua contra interferências de radiofrequência.

Cuidado

Alterações ou modificações não aprovadas expressamente pela entidade responsável pela conformidade podem invalidar a autorização do usuário para operar o equipamento. É necessário utilizar um cabo de interface blindado para cumprir os limites de emissão.

Aviso FCC

Este dispositivo está em conformidade com a Parte 15 das normas da FCC.

A operação está sujeita às duas seguintes condições:

1. Este dispositivo não deve causar interferências prejudiciais.
2. Este dispositivo deve aceitar qualquer interferência recebida, incluindo interferências que possam causar um funcionamento indesejado.

Este dispositivo deve ser instalado e utilizado mantendo uma distância mínima de 20 cm entre o radiador e o corpo humano.

PT

2. Segurança

Atenção: exposição à radiação de radiofrequência

Este equipamento está em conformidade com os limites de exposição à radiação estabelecidos pela FCC para um ambiente não controlado e cumpre as Diretrizes de Exposição à Radiofrequência (RF) da FCC.

Instalação conjunta

Este transmissor não deve ser instalado no mesmo local nem operado em conjunto com qualquer outra antena ou transmissor.

2.7 Aviso Anatel

Resolução 680:

Este equipamento não pode ser protegido contra interferências prejudiciais e não deve causar interferências em sistemas devidamente autorizados.

Resolução 715:

Para mais informações, acesse o site da ANATEL - www.anatel.gov.br

2.8 Aviso IFT

A operação deste equipamento está sujeita às duas condições a seguir: (1) este equipamento ou instrumento não deve causar interferência prejudicial e (2) este equipamento ou instrumento deve aceitar qualquer interferência, incluindo interferências que possam causar funcionamento indesejado.

2.9 Japanese radio law notice

当該機器には電波法に基づく、技術基準適合証明等を受けた特定無線設備を装着している。

PT

3. Segurança na transmissão de dados

3. Segurança na transmissão de dados

3.1 Bluetooth® Low Energy

Bluetooth® Low Energy comunica na banda ISM de 2,4 GHz, isenta de licença, e é um padrão de rádio energeticamente eficiente e harmonizado globalmente.

Bluetooth® Low Energy utiliza 40 canais entre 2,402 GHz e 2,480 GHz.

A criptografia é realizada utilizando o algoritmo de criptografia AES 128 em combinação com a substituição distribuída de chaves.

O instrumento transmite os valores medidos de pressão e temperatura como uma mensagem de difusão opcional nos canais de publicidade 37, 38 e 39, além do nome do instrumento e do nível de carga da bateria.

Mais informações, bem como opções detalhadas de configuração e comandos, estão disponíveis por meio de uma conexão ponto a ponto.

O emparelhamento é estabelecido por meio de um método de inserção de senha e requer a inserção de um código de segurança.



O emparelhamento é estabelecido por meio de um método de inserção de senha e requer a inserção de um código de segurança. As configurações do instrumento só podem ser acessadas após a conclusão do emparelhamento. A chave de emparelhamento de cada instrumento é aleatória. A chave de emparelhamento inicial pode ser encontrada no guia de início rápido incluído.

Se o código de segurança for digitado incorretamente 5 vezes, o instrumento será bloqueado para conexão com esse código. Após desligar a alimentação elétrica ou remover a bateria, ficam novamente disponíveis 5 tentativas. Se isso não for possível por motivos técnicos, por exemplo, porque não é possível acessar o sensor para abrir a caixa, entre em contato com o suporte técnico.

PT

3. Segurança na transmissão de dados

3.2 Conteúdo do código QR na etiqueta do produto (exemplo)



BT:D0:E526EA6D495E:S1A01N14MPIG:C9657

Conteúdo	Identificador	Exemplo	Comentário
Prefácio	-	BT	Identificador de tecnologia
ID do esquema	-	D0	-
MAC	-	E526EA6D495E	Endereço MAC da BT: E5:26:EA:6D:49:5E
SerNum	S	S1A01N14MPIG	Número de série alfanumérico da WIKA (11 digitais)
Checksum	C	9657	-

PT

4. Informações sobre transmissão sem fio

4. Informações sobre transmissão sem fio







4.1 Bluetooth®

Banda de frequência	Potência de transmissão	Modelo
Banda ISM: 2,4 GHz	+4 dBm / 2,51 mW	NETRIS®1
		NETRIS®F
		PEW-1000
		TRW
		CPG1500
		CPH7000
		GDI-100-D
	+5,2 dBm / 3,31 mW	CPG1200

PT

5. Aprovações

5. Aprovações

Logo	Descrição	Região
	Declaração de conformidade UE RED - Diretriz de equipamento de rádio É utilizada a banda de frequência ISM de 2,4 GHz, em conformidade com a norma EN 300 328; Bluetooth® Classic, potência máx. de transmissão de 10 mW. O instrumento pode ser utilizado sem restrições na UE e nos países da Área de Livre Comércio Europeia (EFTA).	União Europeia
	Legislação sobre Rádio do Japão Aprovação válida de rádio	Japão
	Federal Communications Commission (FCC) para os EUA Aprovação de rádio → Se houver um identificador claro (exemplo: „FCC ID: EXAMPLEID“ ou „IC: 12345-ABCDE“) na etiqueta do produto, o instrumento possui uma aprovação de rádio válida para os EUA. O logótipo da FCC indica conformidade com as normas de compatibilidade eletromagnética (EMC) dos EUA.	EUA
-	Innovation, Science and Economic Development (ISED) para o Canadá Aprovação válida de rádio → Se o texto “Contains IC: X8WBC805M” estiver em sua etiqueta de produto, o instrumento terá uma aprovação de rádio válida para o Canadá.	Canadá
-	ICASA (Autoridade Independente de Comunicações da África do Sul) Certificação de rádio	África do Sul
	Regras para equipamentos de radiocomunicação Aprovação válida de rádio Austrália - ABN 49 004 465 936 Nova Zelândia - nº da empresa 400909	Austrália e Nova Zelândia
	IFT Instituto Federal de Telecomunicações Aprovação de rádio	México
	Agência Nacional de Telecomunicações Aprovação válida de rádio	Brasil

PT

5. Aprovações



Algumas aprovações só estão disponíveis mediante solicitação. Para mais informações sobre as aprovações de rádio, consulte www.wika.com.

PT

The Bluetooth® word mark and logos are registered trademarks owned by Bluetooth SIG, Inc. and any use of such marks by WIKA is under licence. Other brands and trademarks are the property of their respective owners.



Importer for UK
WIKAL Instruments Ltd
Unit 6 and 7 Goya Business park
The Moor Road
Sevenoaks
Kent
TN14 5GY



WIKAL Alexander Wiegand SE & Co. KG
Alexander-Wiegand-Strasse 30
63911 Klingenberg • Germany
Tel. +49 9372 132-0
info@wika.de
www.wika.de