

Radio unit with LPWAN

For applications in areas with standard signals

Model NETRIS®1

WIKA data sheet AC 40.01



Applications

- Preventive maintenance
- Remote monitoring of machinery and plants
- Machine building

Special features

- IIoT-capable with LPWAN transmission
- High transmission range for the measured values (up to 10 km [6 mi]) with long battery life (up to 10 years)
- Battery-operated or external power supply for wireless transmission possible
- Easy integration thanks to several radio standards

Description

The model NETRIS®1 is a radio unit to which standard sensors can be connected in order to bring the measured data wirelessly to a cloud for big-data analysis. It uses the licence-free LoRaWAN®, mioty® and Bluetooth® radio standards and is used, for example, on mobile equipment and remote measuring points. Thanks to intelligent measurement and transmission control and a replaceable battery, the radio unit can be operated over a long battery runtime.

The radio unit receives the data via connected measuring instruments with a 0 ... 10 V or 4 ... 20 mA standard signal or an RTD in accordance with the Pt100/Pt1000 standard in 2- or 3-wire technology. The fully encapsulated instrument with IP65 ingress protection transmits the received data continuously to a cloud via configurable data packets with LPWAN or Bluetooth®.

The LPWAN technology (“Low Power Wide Area Network”) enables long transmission ranges and a long battery life.



Left: Model NETRIS®1 with plastic case
Right: Model NETRIS®1 with metal case

A version made of stainless steel is available for applications with harsh ambient conditions.

The instrument can be easily configured via the cloud and the LoRaWAN® network or via the Bluetooth® interface.

Thanks to the compatibility with numerous WIKA measuring instruments and the available radio standards, LoRaWAN® and mioty® for the kilometre range, and Bluetooth® for the metre range, the radio unit can be flexibly configured. Configuration is possible both via the cloud and on-site using Bluetooth® and the “myWIKa wireless device” app.

The WIKA radio unit NETRIS®1 is part of the WIKA IIoT solution. With this, WIKA offers a holistic solution for your digitalisation strategy.

Configurator



Specifications

Overview of versions

Model NETRIS®1 (Lxx)	Version with LoRaWAN® and Bluetooth®
Model NETRIS®1 (Mxx)	Version with mioty® and Bluetooth®
Model NETRIS®1 (Bxx)	Version with Bluetooth®

→ The fields marked with xx are the respective regional abbreviations of the permissible radio standards, for further information, see product label or operating instructions.

Basic information

Supported sensors

RTD	Pt100/Pt1000	°C [°F]
	Potentiometer (1 ... 50 kΩ)	%
Analogue signal	0 ... 20 mA	mA
	4 ... 20 mA	-
	0 ... 10 V	V
Case	<ul style="list-style-type: none"> ■ Plastic version ■ Metal version 	
Power supply	<ul style="list-style-type: none"> ■ Battery ■ External power supply 	

Accuracy specifications

RTD sensor (Pt100/Pt1000)

Accuracy	≤ ±0.1 % of span
Compensation of lead resistance	Max. 10 Ω

RTD sensor (potentiometer)

Accuracy	≤ ±10 % of span
----------	-----------------

Sensor 0 ... 10 V

Accuracy	≤ ±0.1 % of span
Influence of auxiliary power	+0.015 % of span → Per mA when the sensor supply is switched on

Sensor 0 ... 20 mA

Accuracy	≤ ±0.1 % of span
Input resistance	Typically 45 Ω, max. 65 Ω
Load	Max. 500 Ω

Reference conditions	Per IEC 62828-1
-----------------------------	-----------------

Total probable error

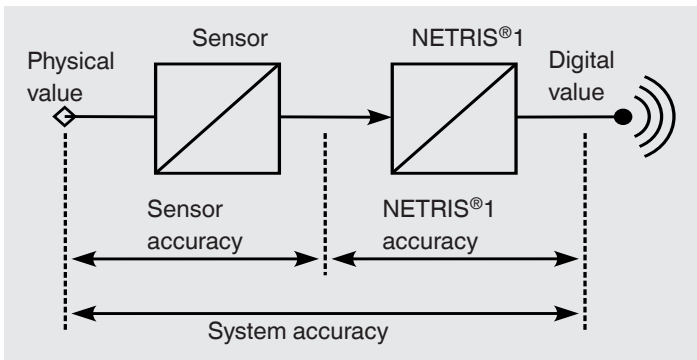

The total probable error must always be considered for the entire system. To do this, the entire chain must be considered, from measuring the physical quantity to obtaining the digital value. The low error entry of the NETRIS®1 must be considered here.

Radio standard	
LoRaWAN®	
Protocol	1.0.3
Functions	<ul style="list-style-type: none"> ■ Registration ■ Configuration ■ Sending measured values ■ Alarm management ■ Battery status
Range in free field	Typically 10 km [6 mi] → Depending on the ambient conditions, such as topography and building structures.
Antenna	PCB antenna, internal
Transmission power	Max. +14 dBm
Transmission interval	Standard 30 minutes
	Minimum 1 minute (maximum transmission interval limited per ETSI EN 300 220) → Limitation of the transmission interval in accordance with ETSI EN 300 220 possible. The maximum transmission frequency and duty cycle comply with the ETSI EN 300 220 standard.
	Maximum 7 days
Safety	Full end-to-end encryption → For details on security, see website: https://lora-alliance.org
mioty®	
Specification	Regional Profile EU1
Functions	<ul style="list-style-type: none"> ■ Registration ■ Sending measured values ■ Alarm management ■ Battery status
Range in free field	Typically 10 km [6 mi] → Depending on the ambient conditions, such as topography and building structures.
Antenna	PCB antenna, internal
Transmission power	Max. 14 dBm
Bluetooth®	
Version	Bluetooth® 5.0 or newer
	→ Compatible with all Bluetooth® Low Energy versions 4.2 or newer
Functions	<ul style="list-style-type: none"> ■ Registration ■ Configuration ■ Sending measured values ■ Alarm management ■ Battery status ■ Data logger

Radio standard	
Range in free field	Typically 10 m [32.8 ft] → Depending on the ambient conditions, such as topography and building structures.
Antenna	Chip antenna, internal
Transmission power	Max. 4 dBm
Transmission interval	1.25 seconds → An update of the measured value only occurs in the set measurement interval.

→ For further information on the radio protocols, see www.wika.com.

Voltage supply and performance data	
Battery	
Battery pack	Lithium thionyl chloride battery and hybrid layer capacitor (model Tadiran HLC1020L) as an assembly with connection cable assembled, see „Spare parts“ . Model Tadiran SL860/S
Battery voltage	DC 3.6 V
Battery life	> 5 years Reference conditions: ■ Measurement interval 30 min. ■ Transmission interval 60 min.
Current supply	Max. 250 mA
External power supply	
Voltage supply	DC 18 ... 30 V
Current supply	Max. 250 mA
Power supply of connected sensors	
Voltage supply	DC 14 V
Current supply	Max. 21 mA

Electrical connection
Connection type
M12 x 1 circular connector (5-pin), A-coded

Pin assignment, M12 x 1 female connector (5-pin), A-coded

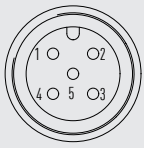
M12 x 1 female connector (5-pin), A-coded	
	1
	2
	3
	4
	5

Pin assignment of free cable ends

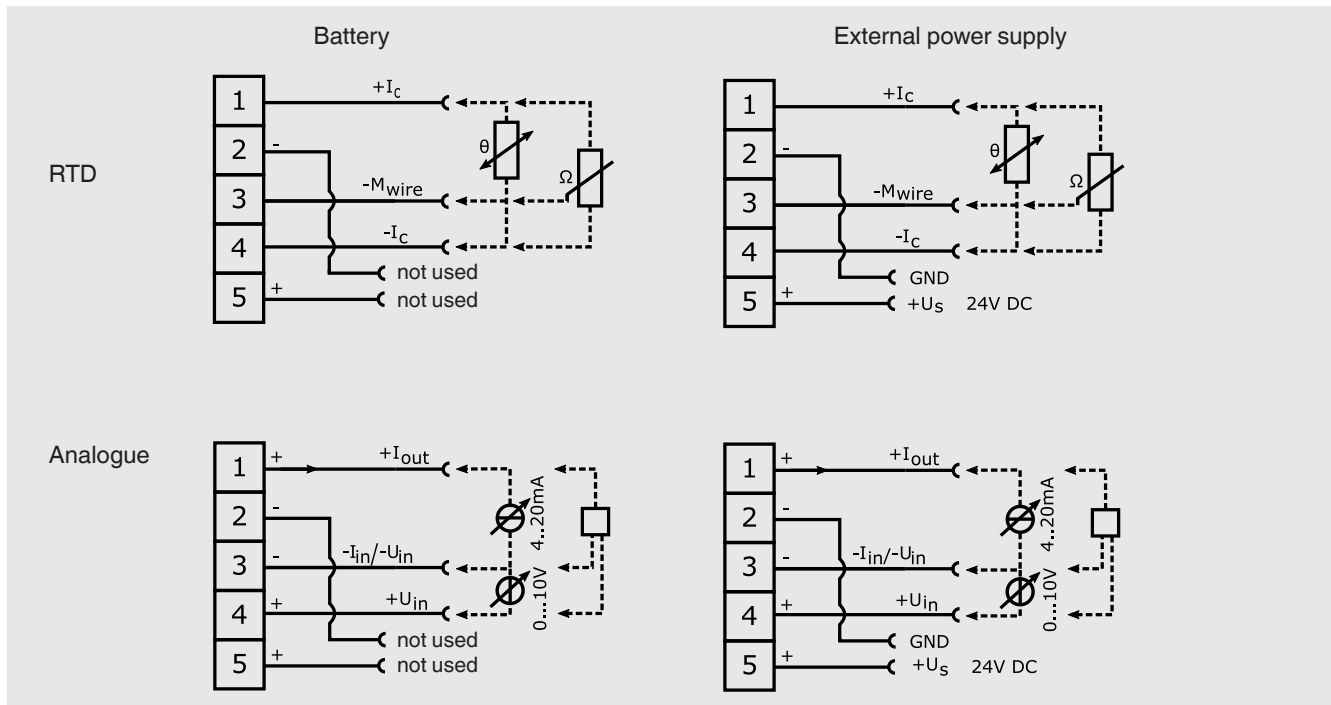

Legend

$+I_{out}$	Current loop output (loop supply)
$-I_{in}$	Current loop input (analogue input for measuring the current)
$+U_{in}$	Input voltage positive (analogue input for measuring the voltage)
$-U_{in}$	Input voltage negative (reference potential for $+U_{in}$)
$+I_c$	Continuous current positive
$-I_c$	Continuous current negative
$-M_{wire}$	Measuring line negative (measuring the lead resistance)
$+U_s$	Supply voltage (DC 24V recommended)
GND	Mass (ground)

Operating conditions

Ambient temperature range

Plastic version	Battery	-20 ... +60 °C [-4 ... +140 °F]
	External power supply	-20 ... +60 °C [-4 ... +140 °F]
Metal version	Battery	-20 ... +60 °C [-4 ... +140 °F]
	External power supply	-40 ... +60 °C [-40 ... +140 °F]
Storage temperature range	-40 ... +70 °C [-40 ... +158 °F]	
Relative humidity	20 ... 90 %	
Condensing	Non-condensing	
Operating altitude	2,000 m [6,562 ft] above sea level	
Pollution degree per EN 61010-1	2	
Overtoltage category	I	
Vibration resistance per IEC 60068-2-6	$a = 1 \text{ g}$ (7 ... 18 Hz) $A = 0.8 \text{ mm}$ (18 ... 50 Hz) $a = 5 \text{ g}$ (10 ... 200 Hz)	
Shock resistance per IEC 60068-2-27	10 g, 11 ms	
Free fall per IEC 60068-2-31		
Individual packaging	1.2 m [3.94 ft]	
Ingress protection	■ IP65 ■ IP67 (only for plastic version)	

Alarms	
Settable alarms	Various alarms can be set. → See WIKA radio unit operating instructions; item number 14614412

Packaging and instrument labelling	
Packaging	Individual packaging
Instrument labelling	<ul style="list-style-type: none"> ■ WIKA product label, lasered ■ Customer-specific product label on request

LPWAN infrastructure

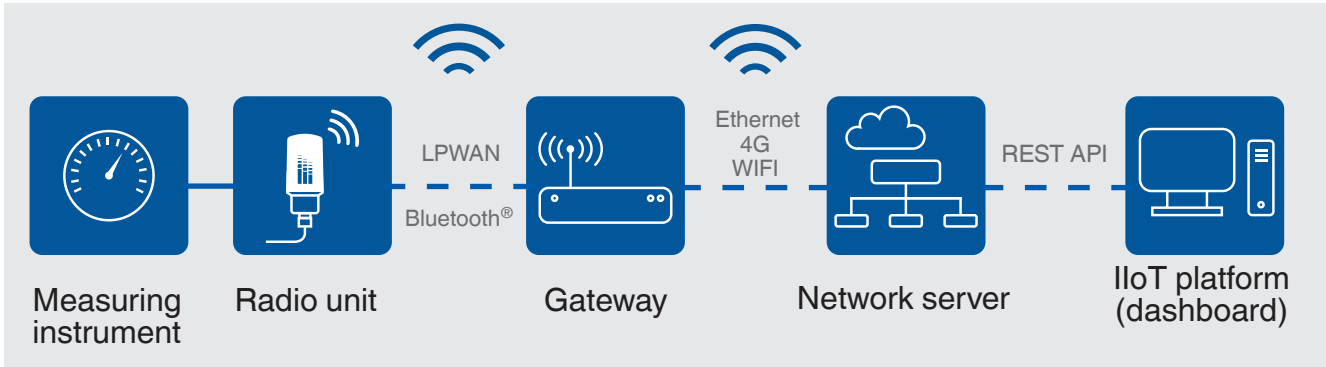

A measuring instrument that allows remote monitoring via radio must be integrated into the IIoT infrastructure. The following schematic illustration shows a typical LPWAN infrastructure:

Data is transmitted wirelessly via the NETRIS®1 to the gateway. It is ensured that only authorised devices may communicate with the network server (e.g. LoRaWAN®). For this, the measuring instrument must first be coupled with the network server. With LPWAN, the wireless transmission can be up to 10 km [6 mi]. The ranges are dependent on factors such as topography, placement of the gateway and environmental influences.

Measured values from several hundred LPWAN enabled IIoT devices of the NETRIS®1 can be collected by a gateway and transmitted to the network server via cable (e.g. via Ethernet) or over-the-air (e.g. 4G or WLAN).

In a web-based IIoT platform, the measured data can be stored, alarms can be set and configurations can be made on the instrument. If the limit values are exceeded, alarm messages can be sent as notification via e-mail. The measured data can be analysed via the visualisation in the dashboard, thus enabling remote monitoring of the measured values. WIKA provides the “myWIKa wireless device” app to support commissioning and local status enquiries of the measuring instrument.

“myWIKa wireless device” app

Via the “myWIKa wireless device” app, the radio unit can be activated and deactivated through a mobile device. Furthermore, the instrument data and the current measured values can be read.

The app functions are used via Bluetooth® and a Bluetooth®-capable mobile device.



Functions of the app:

- Display of the instrument information
- Indication of the instrument status
- Readout of the current measured values
- Manual join request for the LoRaWAN® network
- Configuration such as measuring and transmission rate, alarm values, etc.



For iOS-based devices, the app is available in the Apple Store via the link below.

[Download here](#)



For Android-based devices, the app is available in the Play Store via the link below.

[Download here](#)



Approvals

Logo	Description	Region
	EU declaration of conformity	European Union
	RED – Radio Equipment Directive	
	The instrument may be used without restriction in the following areas: EU and UK, CH, NO, LI	
	RoHS directive	
	CSA	USA and Canada
	Safety (e.g. electr. safety, overpressure, ...)	

→ For approvals and certificates, see website

Dimensions in mm [in]

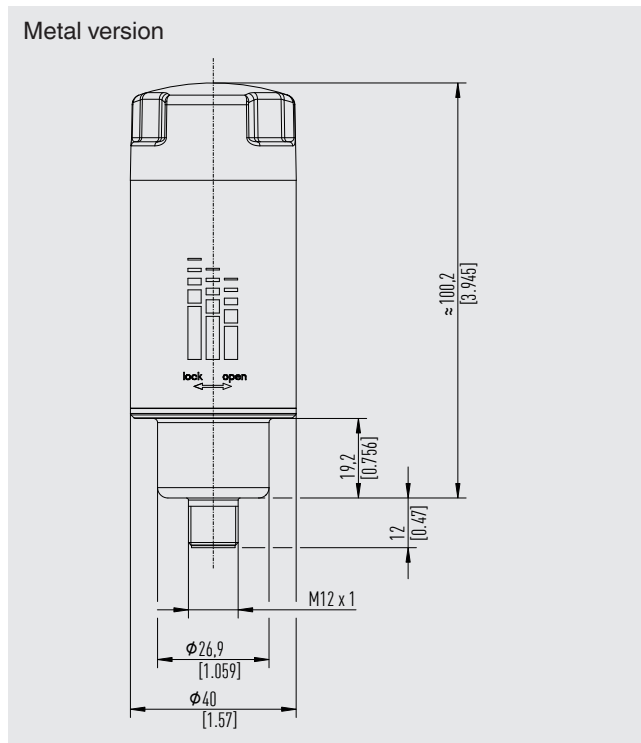
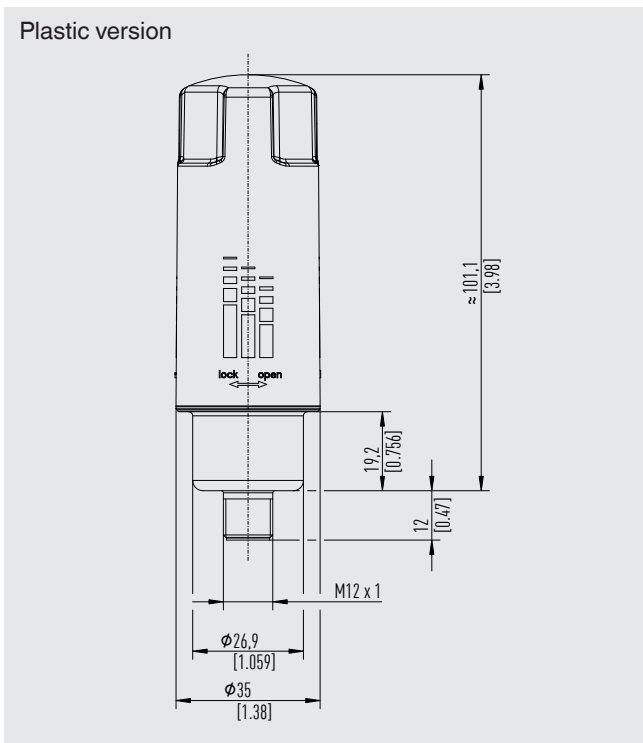

Accessories

Description	Order number
LoRaWAN® gateway, preconfigured for WIKA network server	
Gateway for indoor use	On request
Gateway for outdoor use	On request

Spare parts

Description	Order number
Battery pack 	Lithium thionyl chloride battery and hybrid layer capacitor (model Tadiran HLC1020L) as an assembly with connection cable assembled.
	Model Tadiran SL860/S
Y cable	1 m [3.23 ft]
	3 m [9.84 ft]
Direct cable	1 m [3.23 ft]
	3 m [9.84 ft]
Mounting kit	Wall mounting
	Pipe diameter 25 ... 45 mm [0.98 ... 1.77 in]
	Pipe diameter 70 ... 92 mm [2.76 ... 3.62 in]
	Pipe diameter 146 ... 168 mm [5.75 ... 6.61 in]

Ordering information

Model / Connection to platform / Electrical connection

LoRaWAN® is a trademark used under license from LoRa Alliance®.

mioty® is a registered trademark of Fraunhofer IIS.

The Bluetooth® word mark and logos are registered trademarks owned by Bluetooth SIG, Inc. and any use of such marks by WIKA is under licence. Other brands and trademarks are the property of their respective owners.

© 05/2022 WIKA Alexander Wiegand SE & Co. KG, all rights reserved.

The specifications given in this document represent the state of engineering at the time of publishing.

We reserve the right to make modifications to the specifications and materials.

