

# Radio unit with LoRaWAN<sup>®</sup>, 4 ... 20 mA input signal

## For applications in hazardous areas

### Model NETRIS<sup>®</sup>2

WIKA data sheet AC 40.02



For further approvals,  
see page 5



#### Applications

- Preventive maintenance
- Remote monitoring of machinery and plants
- Process industry: oil and gas, chemical and petrochemical industries, water and wastewater, power generation
- For use in hazardous areas

#### Special features

- IIoT-capable with LoRaWAN<sup>®</sup> transmission
- Battery-operated LoRaWAN<sup>®</sup> wireless transmission based on LPWAN technology
- High transmission range for the measured values (up to 10 km [6 mi]) with long battery life (up to 10 years)
- Two intrinsically safe analogue inputs for 4-20mA signals
- The determination of differential pressures is possible.



WIKA radio unit, model NETRIS<sup>®</sup>2

Configurator



#### Description

Wherever centralised, web-based remote monitoring of measuring instrument data is required, the IIoT-capable WIKA radio unit model NETRIS<sup>®</sup>2 finds its application.

The Ex radio unit receives the data via the two intrinsically safe, analogue 4 ... 20 mA input signals. The fully encapsulated instrument with IP55 ingress protection transmits the received data continuously to a cloud via configurable data packets with LoRaWAN<sup>®</sup> (Long Range Wide Area Network).

Battery-operated wireless transmission via LoRaWAN<sup>®</sup> is based on LPWAN technology to enable high transmission ranges and long battery life.

The radio unit is connected to a suitable measuring instrument via cable.

The simple web configuration via the cloud and the LoRaWAN<sup>®</sup> network enables the complete end-to-end encryption with bidirectional communication for safe IIoT applications.

The WIKA radio unit NETRIS<sup>®</sup>2 is part of the WIKA IIoT solution. With this, WIKA offers a holistic solution for your digitalisation strategy.

# Specifications

Basic information	
Case	Plastic
Lower part of the case	<ul style="list-style-type: none"> <li>■ Without</li> <li>■ With pressure compensating diaphragm</li> </ul>
Power supply	Battery

Accuracy specifications	
<b>Sensor 4 ... 20 mA</b>	
Accuracy	$\leq \pm 0.1\%$ of span
Open-circuit voltage	$U_0$ 23 V
Internal resistance	$R_i$ $292 \pm 1\%$ $\Omega$
Measuring resistor	$R_m$ $49.9 \pm 0.1\%$ $\Omega$
Load	$R_{burden}$ Max. 694 $\Omega$ at 23 mA
Reference conditions	Per IEC 62828-1

## Total probable error

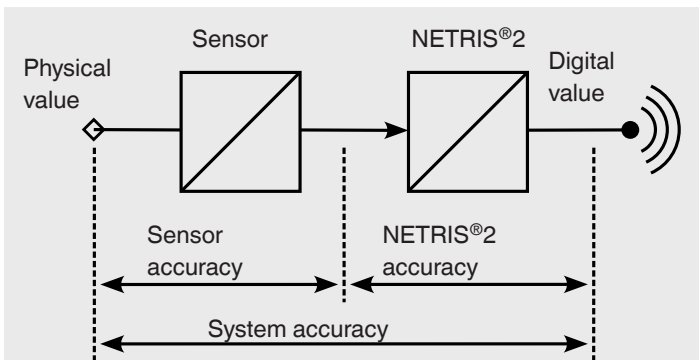

The total probable error must always be considered for the entire system. To do this, the entire chain must be considered, from measuring the physical quantity to obtaining the digital value. The low error entry of the NETRIS®2 must be considered here.

Radio standard		
<b>LoRaWAN®</b>		
LoRaWAN® protocol	Version 1.0.3	
Functions	<ul style="list-style-type: none"> <li>■ Registration</li> <li>■ Configuration of measuring and transmission rate</li> <li>■ Sending measured values</li> <li>■ Alarm management</li> </ul>	
Range in free field <sup>1)</sup>	Typically 10 km [6 mi]	
Antenna	PCB antenna, internal	
Max. transmission power	+14 dBm	
Measurement interval	Standard	30 minutes
	Minimum	1 minute (maximum transmission rate limited per ETSI EN 300 220) → Limitation of the transmission interval in accordance with ETSI EN 300 220 possible. The maximum transmission frequency and duty cycle comply with the ETSI EN 300 220 standard.
	Maximum	7 days

## Radio standard

### Security

Full end-to-end encryption

→ For details on security, see website: <https://loro-alliance.org>

1) The range depends on the topography. 10 km [6 mi] can be achieved in free field conditions with a spreading factor of 12.

## Voltage supply and performance data

### Battery pack

WIKA Lithium thionyl chloride / Hybrid layer capacitor (HLC) battery, 3.6 V, potted Model Eve BN2D150

### Battery voltage

DC 3.6 V

### Battery life

Max. 10 years

→ At reference conditions a measurement and a transmission every hour (24 x a day) takes place at spreading factor 10.

## Electrical connection

### Connection type

Board connector

### Wire cross-section

0.05 mm<sup>2</sup> ... 1.5 mm<sup>2</sup>

### Pin assignment

→ See table „Pin assignment“

### Short-circuit resistance

Yes

### Reverse polarity protection

Yes

### Sealing inserts Ø

- 4.5 ... 5 mm [1.77 ... 0.20 in]
- 6 mm [0.24 in]
- 7.2 mm [0.28 in]
- 8.6 mm [0.34 in]
- 10 mm [0.39 in]
- 4.5 ... 5 mm [1.77 ... 0.20 in] (dual)

## Pin assignment

### Board connector

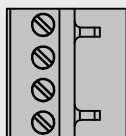

1 Supply 1

2 Signal 1

3 Signal 2

4 Supply 2

Operating conditions	
Ambient temperature range	-30 °C [-22 °F] ≤ Ta ≤ +60 °C [+140 °F]
Storage temperature range	-40 ... +70 °C [-40 ... +158 °F]
Humidity	20 ... 90 % relative humidity
Condensation	Non-condensing
Vibration resistance per IEC 60068-2-6	a = 1g (7 ... 18 Hz) 10 ... 14.53 Hz A = 0.8 mm (18 ... 50 Hz) a = 5g (50 ... 200 Hz) <sup>1)</sup>
Shock resistance per IEC 60068-2-31 <sup>1)</sup>	25g, 6 ms
Free fall per IEC 60068-2-31	
Individual packaging	1.2 m [3.94 ft]
Multiple packaging	0.5 m [1.6 ft]
Ingress protection per IEC/EN 60529	IP55/57

1) Mounting with cable ties can only be made under vibration-free conditions.

## LPWAN infrastructure

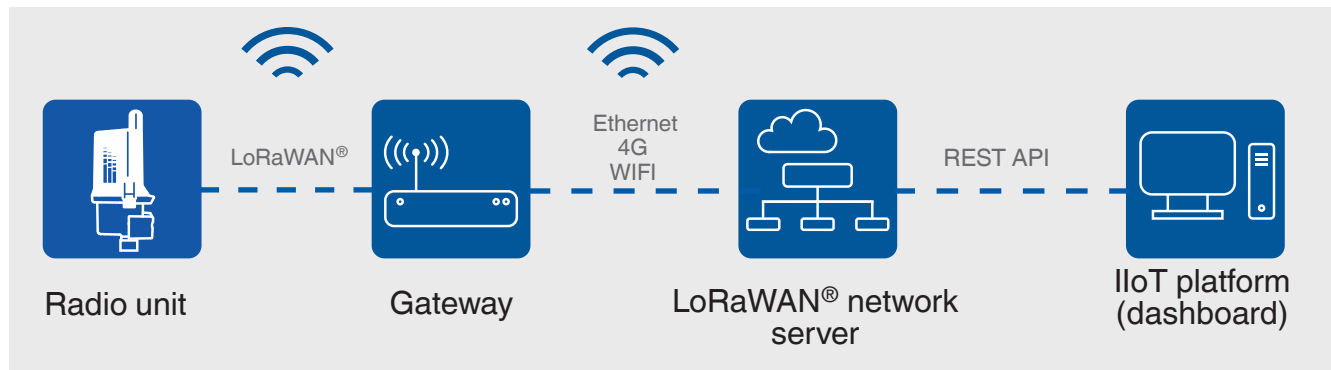



Data from a measuring instrument with a 4 ... 20 mA signal is transmitted via a cable to the radio unit and on to the gateway via radio. It is ensured that only authorised end devices may communicate with the network server. For this, the measuring instrument must first be coupled with the network server. In LoRaWAN®, the wireless transmission can be up to 10 km [6 mi]. The ranges are dependent on factors such as topography, placement of the gateway or environmental influences.

Measured values from several hundred LoRaWAN®-enabled IIoT devices from the WIKA-IIoT-Solution portfolio can be collected by a gateway and transmitted to the network server via cable (e.g. Ethernet) or over-the-air (e.g. 4G or WLAN).

In a web-based IIoT platform, the measured data can be stored, alarms can be set and configurations can be made on the instrument. If the limit values are exceeded, alarm messages can be sent as notification via e-mail from the cloud. The measured data can be analysed via the visualisation in the dashboard, thus enabling remote monitoring of the measured values.

## Approvals

Logo	Description	Region
	<b>EU declaration of conformity</b>	European Union
	RED - Radio Equipment Directive The instrument may be used without restriction in the following areas: EU and UK, CH, NO, LI	
	RoHS directive	
	<b>EU declaration of conformity</b>	European Union
	ATEX directive Hazardous areas - Ex i Zone 0 gas II 1(1)G Ex ia [ia Ga] IIC T3 Ga	
	<b>IECEX</b> Hazardous areas - Ex i Zone 0 gas Ex ia [ia Ga] IIC T3 Ga	International

## Safety-related characteristic values (Ex)

Safety-related characteristic values (Ex)						
<b>Ex marking</b>						
<b>Parameters</b>						
Max. voltage $U_o$	$\leq 26$ V					
Max. current $I_o$	$\leq 90$ mA					
Max. power $P_o$	$\leq 550$ mW					
Internal capacitance $C_i$	3.6 nF					
Internal inductance $L_i$	0.3 mH					
<b>Output parameters <sup>1)</sup></b>						
Gases of group IIB	Max. external inductance $L_0$	25.7 mH	19.7 mH	9.7 mH	4.7 mH	
	Max. external capacitance $C_0$	446 nF	486 nF	566 nF	686 nF	
Gases of group IIC	Max. external inductance $L_0$	2.2 mH	1.7 mH	0.7 mH	0.2 mH	
	Max. external capacitance $C_0$	37 nF	43 nF	60 nF	78 nF	
<b>Temperature ranges</b>						
Temperature class	T3					

1) The values show the combinations of  $L_0$  and  $C_0$ , including the occurring mains reactance, for the connection to the sensor subcircuit in the respective gas group. The internal capacitance  $C_i = 3.6$  nF and the inductance  $L_i = 0.3$  mH have already been taken into account.

## Dimensions in mm [in]

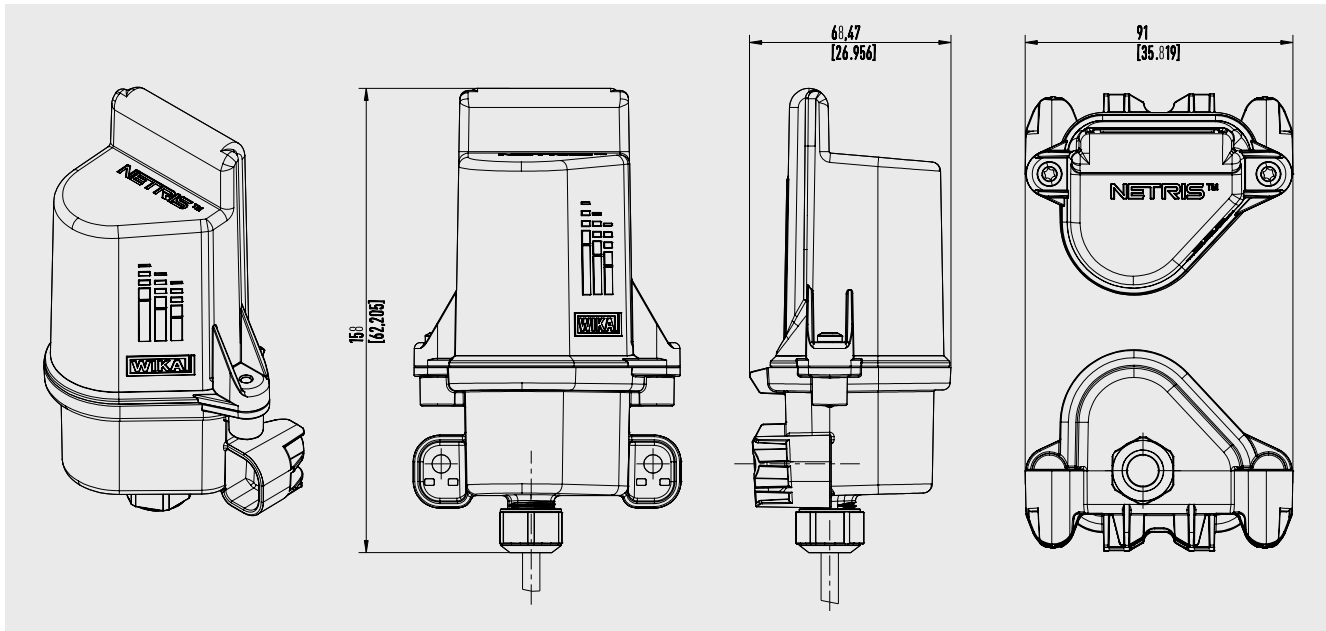

## Accessories

Description	Order number
<b>LoRaWAN® gateway, preconfigured for WIKA network server</b> Gateway for indoor use Gateway for outdoor use	On request

## Spare parts

Description	Order number
<b>Battery pack</b> WIKA Lithium thionyl chloride / Hybrid layer capacitor (HLC) battery, 3.6 V, potted Model Eve BN2D150	14635440

## Ordering information

Model / Pressure compensating valve / Connection to platform

The LoRa® brand and the LoRa logo are trademarks of Semtech Corporation.  
 LoRaWAN® is a trademark used under licence from LoRa Alliance®.

Configurator



© 03/2023 WIKA Alexander Wiegand SE & Co. KG, all rights reserved.  
 The specifications given in this document represent the state of engineering at the time of publishing.  
 We reserve the right to make modifications to the specifications and materials.

