

# Miniature resistance thermometer for connection to WIKA radio unit Model TRU

WIKA data sheet TE 63.03



for further approvals,  
see page 5

## Applications

- Condition-based and preventive maintenance through centralised big data analysis
- Energy and power plant technology
- Chemical industry
- Food and beverage industry
- Sanitary, heating and air-conditioning technology

## Special features

- IIoT-capable measuring instrument in combination with WIKA radio unit, model NETRIS®3
- Sensor range from -196 ... +500 °C [-321 ... +932 °F]
- For direct installation into the process or common thermowell designs
- Intrinsically safe version Ex i
- Very compact design

## Description

The model TRU miniature resistance thermometer in combination with the model NETRIS®3 radio unit is used wherever web-based remote monitoring of the process pressure is desired. Condition-based and preventive maintenance through centralised big data analysis is thus possible.

Resistance thermometers in this series can be installed directly into the process or combined with a large number of thermowell designs. Surface temperature measurements, e.g. on a tubeskin, can be performed using a tightening strap. The instruments are intrinsically safe and suitable for use in hazardous areas.

## Miniature resistance thermometer for connection to WIKA radio unit, model TRU



All electrical components are protected against powerful water jet (IP66) and the effects of temporary immersion in water (IP67) and designed to withstand vibration (10 g amplitude / 20 g peak-to-peak, depending on instrument version).

The resistance thermometer has an integrated transmitter that sends and receives data via a digital interface. The electrical connection is made via an M12 x 1 circular connector.

The resistance thermometer model TRU is part of the WIKA IIoT solution. With this, WIKA offers a holistic solution for your digitalisation strategy.

Configurator



**Installation example**

Model TRU with mounted WIKA radio unit, model NETRIS®3

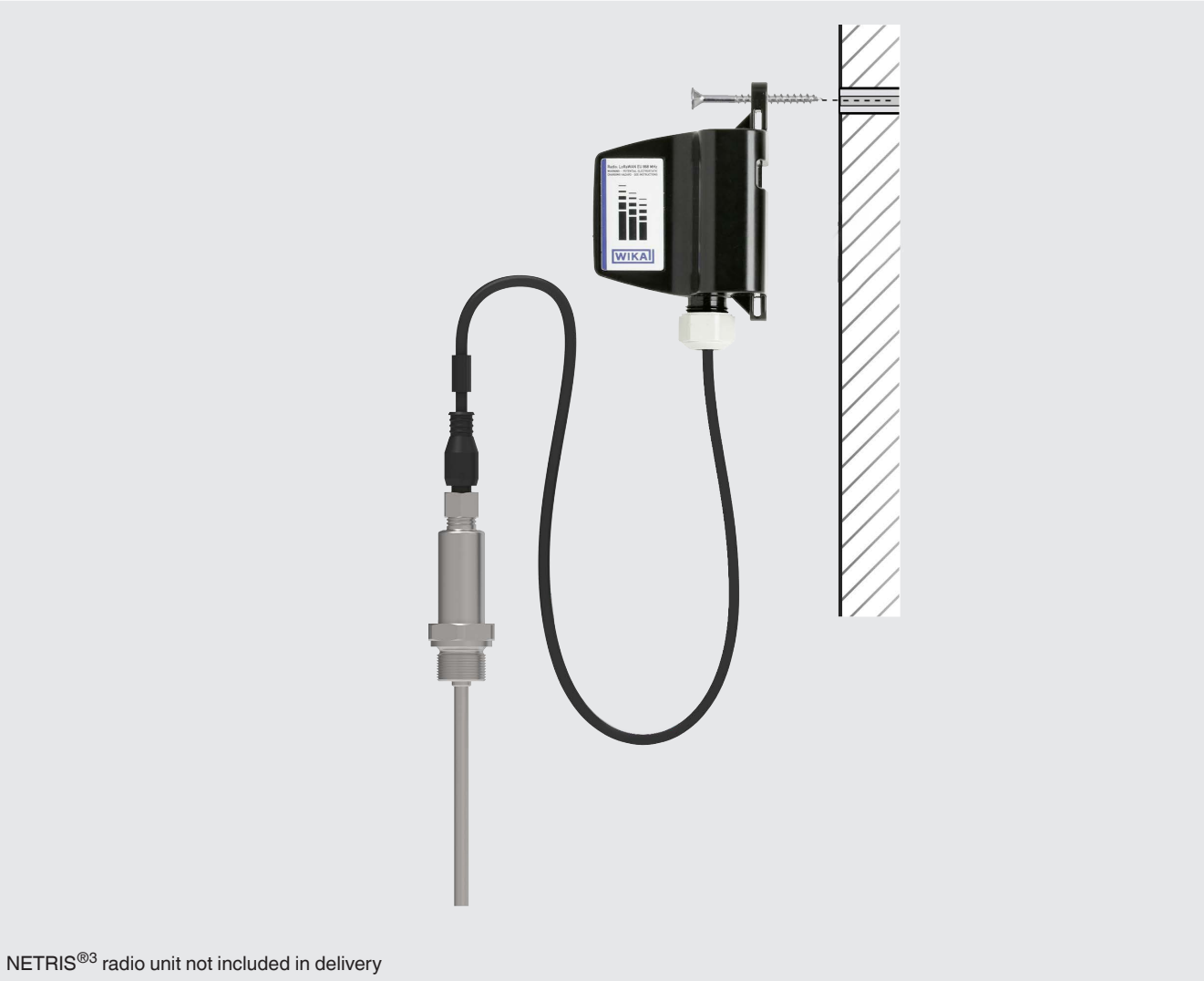

# Specifications

Measuring range	
Temperature range <sup>1)</sup>	<ul style="list-style-type: none"> <li>■ -196 ... +300 °C [-321 ... +572 °F]</li> <li>■ -50 ... +300 °C [-58 ... +572 °F]</li> <li>■ -50 ... +500 °C [-58 ... +932 °F]</li> </ul>
	Version with FKM O-ring: -20 ... +125 °C [-4 ... +257 °F]
Temperature at the connector	Max. 105 °C [221 °F]

1) The temperature transmitter should therefore be protected from temperatures below -40 °C [-40 °F] and over 105 °C [221 °F].

Process connection	
Type of process connection	<ul style="list-style-type: none"> <li>■ G ¼ B</li> <li>■ G ⅜ B</li> <li>■ G ½ B</li> <li>■ ¼ NPT</li> <li>■ ½ NPT</li> <li>■ M12 x 1.5</li> <li>■ M20 x 1.5</li> <li>■ 7/16-20 UNF-2A</li> <li>■ without</li> <li>■ G ¼ B compression fitting (metal ferrule)</li> <li>■ G ⅜ B compression fitting (metal ferrule)</li> <li>■ G ½ B compression fitting (metal ferrule)</li> <li>■ ¼ NPT compression fitting (metal ferrule)</li> <li>■ ½ NPT compression fitting (metal ferrule)</li> <li>■ G ¼ B compression fitting (PTFE ferrule)</li> <li>■ G ⅜ B compression fitting (PTFE ferrule)</li> <li>■ G ½ B compression fitting (PTFE ferrule)</li> <li>■ ¼ NPT compression fitting (PTFE ferrule)</li> <li>■ ½ NPT compression fitting (PTFE ferrule)</li> <li>■ G ⅜ union nut, spring-loaded sensor (for additional thermowell)</li> <li>■ M24 x 1.5 female thread, spring-loaded sensor (for additional thermowell / neck tube)</li> <li>■ Tightening strap (for fitting on tubeskins)</li> </ul>
Sensor	
Sensor diameter	<ul style="list-style-type: none"> <li>■ 3 mm [0.12 in]</li> <li>■ 6 mm [0.24 in]</li> </ul>
Insertion length <sup>1)</sup>	<ul style="list-style-type: none"> <li>■ 50 mm [1.97 in]</li> <li>■ 75 mm [2.95 in]</li> <li>■ 100 mm [3.94 in]</li> <li>■ 120 mm [4.72 in]</li> <li>■ 150 mm [5.91 in]</li> <li>■ 200 mm [7.87 in]</li> <li>■ 250 mm [9.84 in]</li> <li>■ 300 mm [11.81 in]</li> <li>■ 350 mm [13.78 in]</li> <li>■ 400 mm [15.75 in]</li> </ul>
	Other insertion lengths on request

1) The first 60 mm [2.59 in] of the probe tip must not be bent. At the transition to the transmitter, bending is allowed at a distance of 30 mm [1.18 in] from the case. The sheath resistance thermometer may be bent with the radius 5 times the diameter.

Digital interface	
Signal type	Unified WIKA interface (UWI)
Digital signal resolution	10 mK
Connection type	M12 x 1 circular connector, pin assignment suitable for use with WIKA radio unit model NETRIS®3
Accuracy	Overall accuracy incl. WIKA radio unit (NETRIS®3): <ul style="list-style-type: none"> <li>■ Measuring range ≤ 300 °C: +/- 1.9 °K</li> <li>■ Measuring range &gt; 300 °C: +/- 2.9 °K</li> </ul>

Material	
<b>Materials (wetted)</b>	
Sheath material	<ul style="list-style-type: none"> <li>■ Stainless steel 1.4571 (316 Ti)</li> <li>■ Stainless steel 1.4435 (316L)</li> </ul>
Process connection	<ul style="list-style-type: none"> <li>■ Stainless steel 1.4571 (316 Ti)</li> <li>■ Stainless steel 1.4435 (316L)</li> </ul>

Operating conditions	
Ambient and storage temperature range	-40 ... +105 °C [-40 ... +221 °F] Version with FKM O-ring -20 ... +105 °C [-4 ... +221 °F]
Climate class per IEC 60654-1	Cx (-40 ... +105 °C [-40 ... +221 °F], 5 ... 95 % r. h.) Version with FKM O-ring: -20 °C [-4 °F]
Maximum permissible humidity, condensation	100 % r. h., condensation allowed
<b>Maximum operating pressure</b> <sup>1) 2)</sup>	
With sensor diameter 3 mm [0.12 in]	140 bar [2,030 psi]
With sensor diameter 6 mm [0.24 in]	270 bar [3,916 psi]
Salt mist	IEC 60068-2-11
Vibration resistance per IEC 60751	10 ... 2,000 Hz, max. 10 g amplitude / 20 g peak-to-peak <sup>3)</sup>
Shock resistance per IEC 60068-2-27	50 g, 6 ms, 3 axes, 3 directions, three times per direction
<b>Ingress protection (IP code)</b>	
Case with connected connector	<ul style="list-style-type: none"> <li>■ IP66 per IEC/EN 60529</li> <li>■ IP67 per IEC/EN 60529</li> </ul> <p>The stated ingress protection only applies when plugged in using line connectors that have the appropriate ingress protection.</p>
Coupler connector, not connected	IP67 per IEC/EN 60529
Weight	Approx. 0.05 ... 0.7 kg [0.11 ... 1.54 lbs] - depending on version

1) Dependent on the instrument version. In combination with an additional thermowell, this determines the maximum operating pressure

2) Reduced operating pressure when using a compression fitting: Stainless steel: max. 100 bar [1,450 psi] / PTFE = max. 8 bar [116 psi]

3) Dependent on the instrument version. Specification applies to instrument versions without neck tube and for a maximum insertion length < 75 mm [2.95 in]

## Safety-related characteristic values (Ex)

Hazardous gas atmosphere	Temperature class	Ambient temperature range (T <sub>a</sub> )	Process temperature
II 1G Ex ia IIC T1 - T6 Ga II 1/2G Ex ia IIC T1 - T6 Ga/Gb II 2G Ex ia IIC T1 - T6 Gb	T6	-40 ... +50 °C [-40 ... +122 °F]	-196 ... +72.5 °C [-321 ... +163 °F]
	T5	-40 ... +75 °C [-40 ... +167 °F]	-196 ... +87.5 °C [-321 ... +190 °F]
	T4	-40 ... +105 °C [-40 ... +221 °F]	-196 ... +122.5 °C [-321 ... +253 °F]
	T3	-40 ... +105 °C [-40 ... +221 °F]	-196 ... +187.5 °C [-321 ... +370 °F]
	T2	-40 ... +105 °C [-40 ... +221 °F]	-196 ... +282.5 °C [-321 ... +541 °F]
	T1	-40 ... +105 °C [-40 ... +221 °F]	-196 ... +432.5 °C [-321 ... +811 °F]



Hazardous dust/air atmospheres	Temperature class / maximum surface temperature	Ambient temperature range (T <sub>a</sub> )	Process temperature
II 1D Ex ia IIIC * Da II 1/2D Ex ia IIIC * Da/Db II 2D Ex ia IIIC * Db	T135 °C T <sub>200</sub> xxx °C	-40 ... +100 °C [-40 ... 212 °F]	-196 ... xxx °C - 9 K <sup>1)</sup>

1) Please take a self heating of 9 K into consideration.

The permissible ambient temperature for the respective category can be seen on the EU-type examination certificate and the certificate for hazardous areas or the operating instructions.

## Approvals

Included in delivery

Logo	Description	Region
	<b>EU declaration of conformity</b>	European Union
	EMC directive EN 61326 emission (group 1, class B) and immunity (industrial application)	
	RoHS directive	
	ATEX directive Hazardous areas - Ex i Zone 0 gas II 1G Ex ia IIC T1 ... T6 Ga Zone 1 mounting to zone 0 gas II 1/2G Ex ia IIC T1 ... T6 Ga/Gb Zone 1 gas II 2G Ex ia IIC T1 ... T6 Gb Zone 20 dust II 1D Ex ia IIIC * Da Zone 21 mounting to zone 20 dust II 1/2D Ex ia IIIC * Da/Db Zone 21 dust II 2D Ex ia IIIC * Db	International
	<b>IECEx - in combination with ATEX</b> Hazardous areas - Ex i Zone 0 gas Ex ia IIC T1 ... T6 Ga Zone 1 mounting to zone 0 gas Ex ia IIC T1 ... T6 Ga/Gb Zone 1 gas Ex ia IIC T1 ... T6 Gb Zone 20 dust Ex ia IIIC * Da Zone 21 mounting to zone 20 dust Ex ia IIIC * Da/Db Zone 21 dust Ex ia IIIC * Db	

# Dimensions in mm [in]

## Process connection with parallel thread (or without process connection)

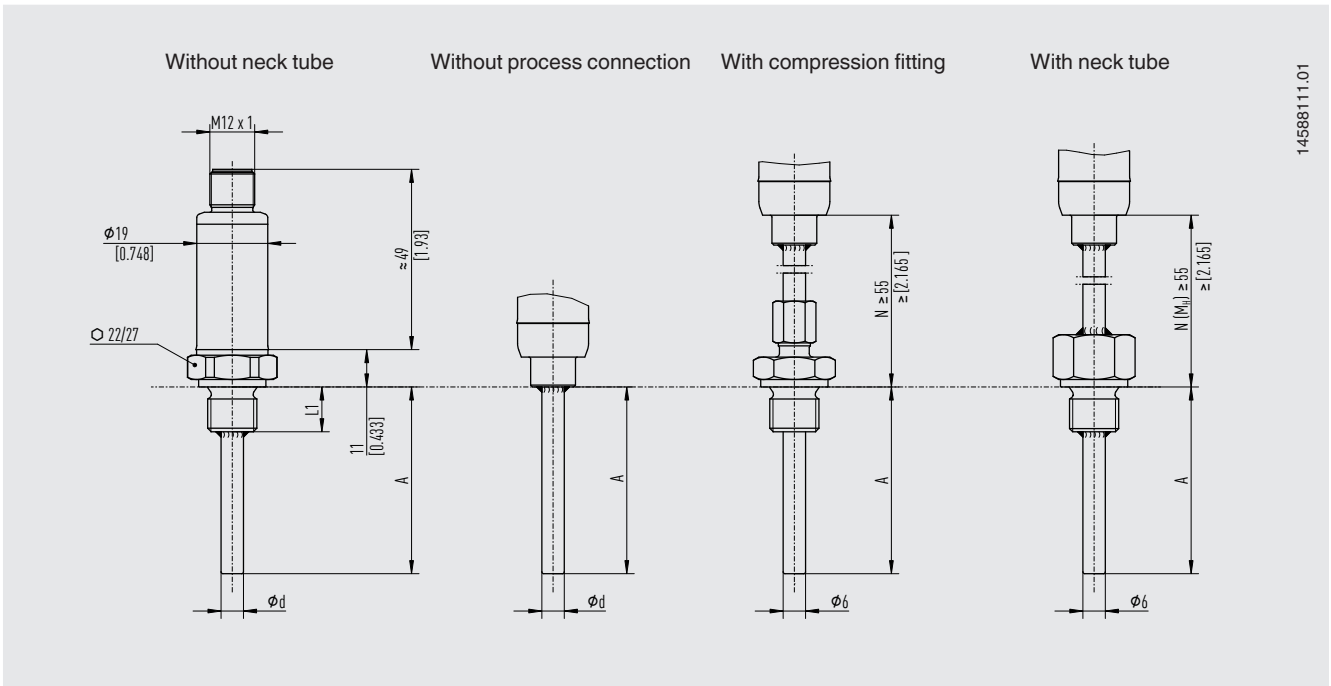

14588111.01

## Process connection with parallel thread (7/16-20 UNF-2A) and O-ring

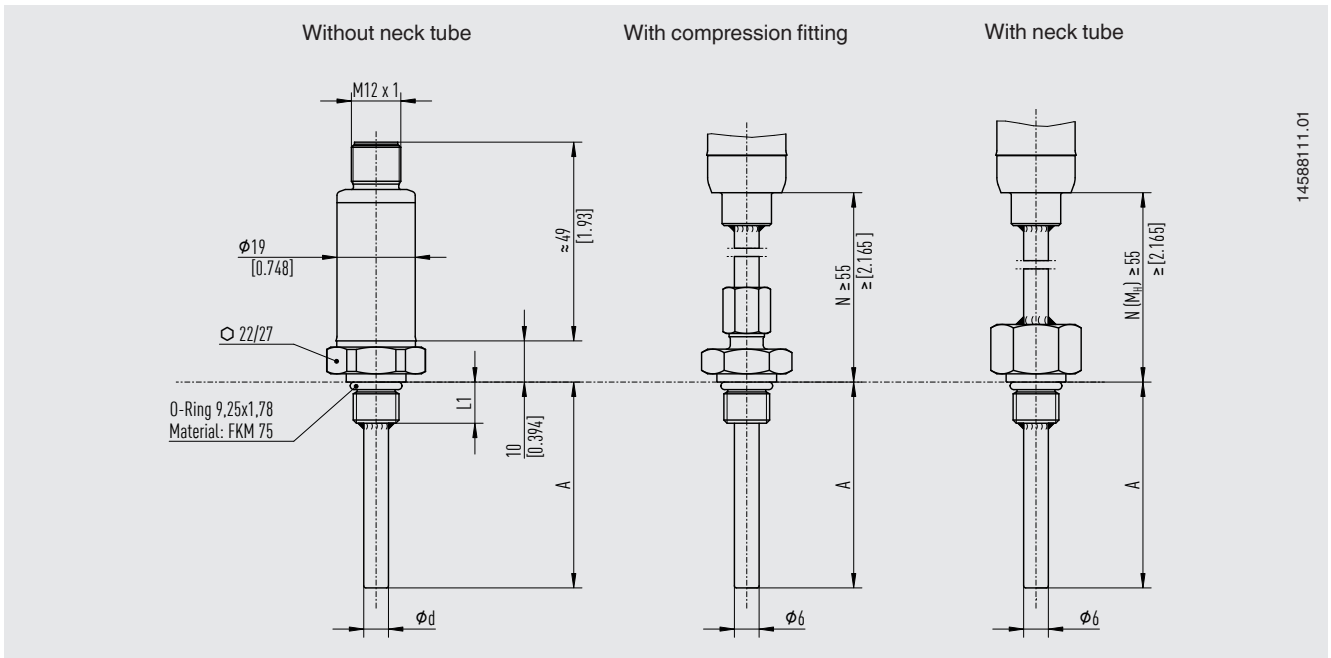

14588111.01

The FKM O-ring must be protected from temperatures lower than  $-20\text{ }^{\circ}\text{C}$  [ $-4\text{ }^{\circ}\text{F}$ ] and higher than  $125\text{ }^{\circ}\text{C}$  [ $257\text{ }^{\circ}\text{F}$ ].

## Process connection with tapered thread

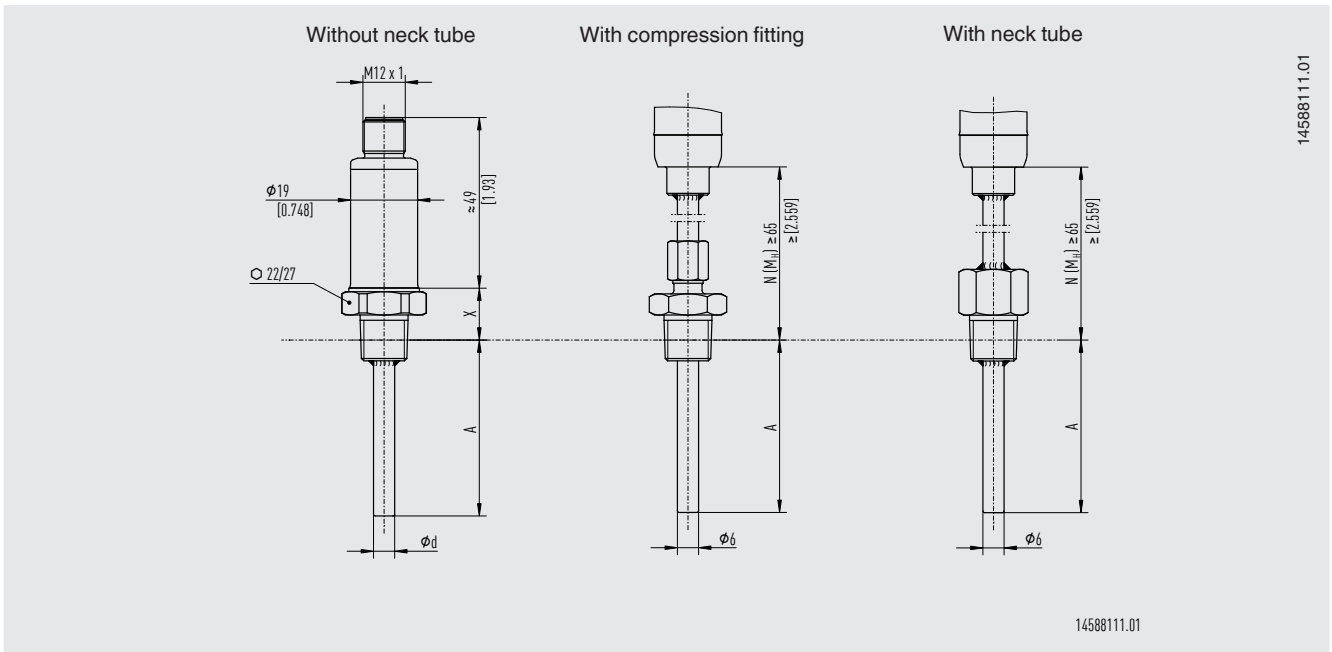

At a process temperature of  $> 150\text{ }^{\circ}\text{C}$  [ $302\text{ }^{\circ}\text{F}$ ], a neck length  $N (M_H)$  of 70 mm [2.76 in] is necessary, otherwise  $N (M_H)$  selectable (55 mm [2.17 in], 65 [2.56 in] or 70 mm [2.76 in]).

## Spring-loaded process connection

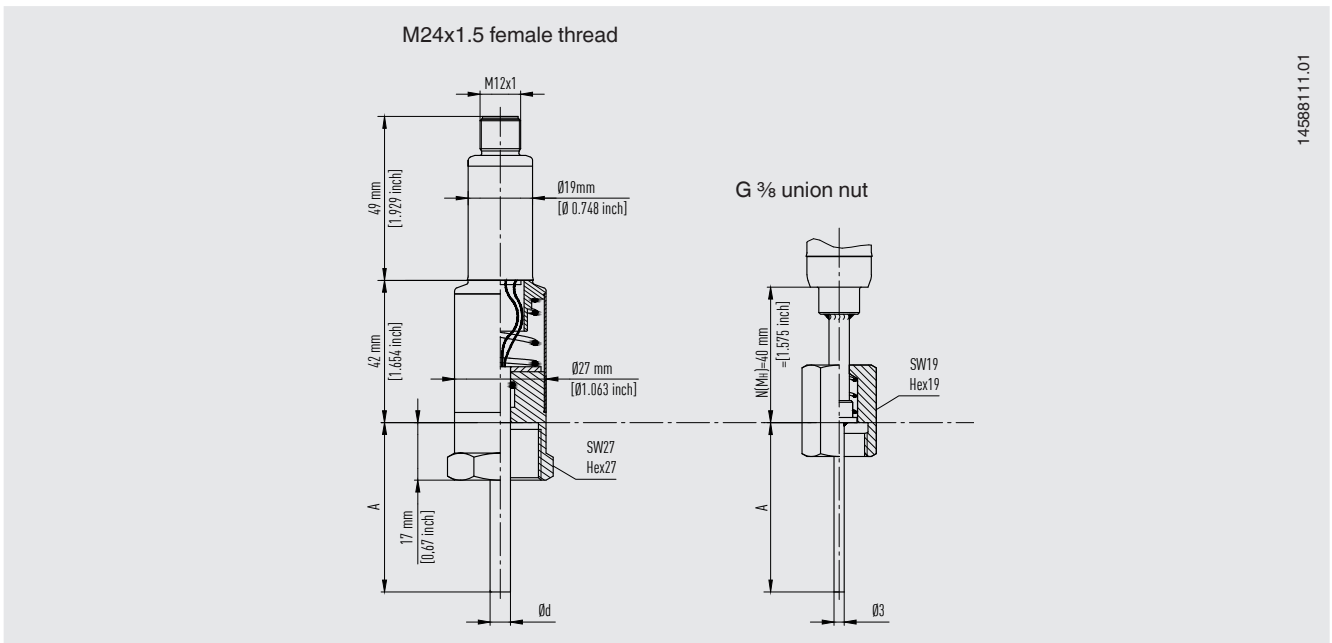

Legend:

A	Insertion length	$\varnothing d$	Sensor diameter
L1	Thread length	X	Height process connection
$N (M_H)$	Neck length		1/4 NPT = 15 mm [0.59 in]
			1/2 NPT = 19 mm [0.75 in]

The neck length depends on the intended use. Usually an isolation is bridged by the neck tube. Also, in many cases, the neck tube serves as a cooling element in order to protect a possible built-in transmitter from high medium temperatures.

## Process connection for tubeskin assembly

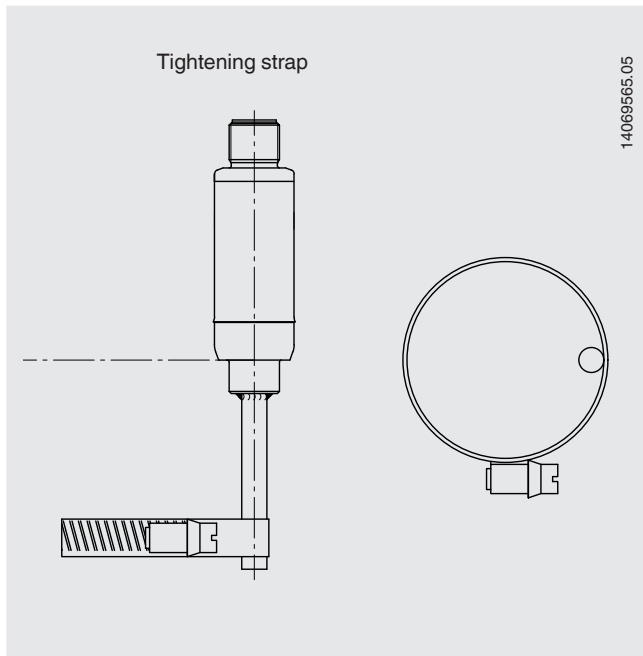

### Tightening strap for tube diameter

11 ... 15 mm [0.43 ... 0.59 in]
13 ... 25 mm [0.51 ... 0.98 in]
23 ... 62 mm [0.91 ... 2.44 in]
60 ... 93 mm [2.36 ... 3.66 in]
91 ... 125 mm [3.58 ... 4.92 in]
123 ... 158 mm [4.84 ... 6.22 in]
Other sizes on request: 159 ... 2,500 mm [6.26 ... 98.43 in]

## Accessories

Description	Relevant data sheet	Further information
NETRIS®3 radio unit	AC 40.03	on request

## Ordering information

Model / Explosion protection / Process temperature / Process connection / Material process connection / Sensor diameter / Sheath material / Insertion length A / neck length N (MH) / Certificates

Configurator



© 04/2023 WIKA Alexander Wiegand SE & Co. KG, all rights reserved.  
The specifications given in this document represent the state of engineering at the time of publishing.  
We reserve the right to make modifications to the specifications and materials.

