

Miniature resistance thermometer with wireless transmission

For general industrial applications

Model TRW

WIKA data sheet TE 63.04



Applications

- Preventive maintenance
- Remote monitoring of machinery and plants
- Energy and power plant technology
- Chemical industry
- Sanitary, heating and air-conditioning technology

Special features

- Long battery life through intelligent measurement control
- Easy integration thanks to several radio-standard options
- Numerous application possibilities – also as retrofit
- Robustly built, permanently reliable temperature measurement



Configurator



Miniature resistance thermometer with wireless transmission, model TRW

Description

The model TRW is a radio-based resistance thermometer for monitoring medium temperatures of all types. Resistance thermometers in this series can be installed directly into the process or combined with a large number of thermowell designs. It uses the licence-free LoRaWAN® and Bluetooth® radio standards and is used, for example, on mobile equipment and remote measuring points. Thanks to intelligent measurement and transmission control and a replaceable battery, the sensor can be operated for years without maintenance.

Long battery life through intelligent measurement control

The intelligent configuration allows measurement and transmission intervals that are dependent on the measured value. In addition, the sensor can measure continuously without transmitting every measured value. This means: high security with low data and energy consumption. All data is available digitally in a cost-efficient way and allows automated analyses.

Easy integration thanks to several radio-standard options

Thanks to numerous process connections and the two available standards – LoRaWAN® for the kilometre range and Bluetooth® for the metre range – the instrument can be flexibly configured.

Numerous application possibilities – also as retrofit

Via retrofit, machinery or moving parts can be configured smartly – without having to plan and document cable routing. Particularly when no continuous measurement is needed, cost advantages can be realised.

Robustly built, permanently reliable temperature measurement

The instrument is built to be robust and vibration-resistant. The battery is preassembled and can be replaced easily. It is not necessary to replace the entire resistance thermometer.

Specifications

Accuracy specifications	
Overall accuracy	<ul style="list-style-type: none"> ■ Measuring range ≤ 300 °C: +/- 1,4 °K ■ Measuring range > 300 °C: +/- 2,9 °K
Reference conditions	Per IEC 62828-1

Measuring range	
Temperature range ¹⁾	<ul style="list-style-type: none"> ■ -196 ... +300 °C [-321 ... +572 °F] ■ -50 ... +300 °C [-58 ... +572 °F] ■ -50 ... +500 °C [-58 ... +932 °F]
Version with FKM O-ring	-20 ... +125 °C [-4 ... +257 °F]

1) The temperature transmitter should therefore be protected from temperatures below -20 °C [-4 °F] and over +60 °C [+140 °F].

Process connection	
Type of process connection	<ul style="list-style-type: none"> ■ G ¼ B ■ G ⅜ B ■ G ½ B ■ ¼ NPT ■ ½ NPT ■ M12 x 1.5 ■ M20 x 1.5 ■ 7/16-20 UNF-2A ■ without ■ G ¼ B compression fitting (metal ferrule) ■ G ⅜ B compression fitting (metal ferrule) ■ G ½ B compression fitting (metal ferrule) ■ ¼ NPT compression fitting (metal ferrule) ■ ½ NPT compression fitting (metal ferrule) ■ G ¼ B compression fitting (PTFE ferrule) ■ G ⅜ B compression fitting (PTFE ferrule) ■ G ½ B compression fitting (PTFE ferrule) ■ ¼ NPT compression fitting (PTFE ferrule) ■ ½ NPT compression fitting (PTFE ferrule) ■ G ⅜ union nut, spring-loaded sensor (for additional thermowell) ■ M24 x 1.5 female thread, spring-loaded sensor (for additional thermowell / neck tube) ■ Tightening strap (for fitting on surface)

Sensor	
Sensor diameter	<ul style="list-style-type: none"> ■ 3 mm [0.12 in] ■ 6 mm [0.24 in]
Insertion length ¹⁾	<ul style="list-style-type: none"> ■ 50 mm [1.97 in] ■ 75 mm [2.95 in] ■ 100 mm [3.94 in] ■ 120 mm [4.72 in] ■ 150 mm [5.91 in] ■ 200 mm [7.87 in] ■ 250 mm [9.84 in] ■ 300 mm [11.81 in] ■ 350 mm [13.78 in] ■ 400 mm [15.75 in] <p>→ Other insertion lengths on request</p>

Thermowell/protection tube ²⁾	
Connection to thermometer	<ul style="list-style-type: none"> ■ G ⅜ union nut, spring-loaded sensor ■ M24 x 1,5 female thread, spring-loaded sensor

1) The first 60 mm [2.59 in] of the probe tip must not be bent. At the transition to the transmitter, bending is allowed at a distance of 30 mm [1.18 in] from the case. The sheathed resistance thermometer may be bent with a radius of 5 times the diameter.

2) Various thermowells/protection tubes can be combined with the TRW.

Thermowell/Protection tube examples for sanitary applications

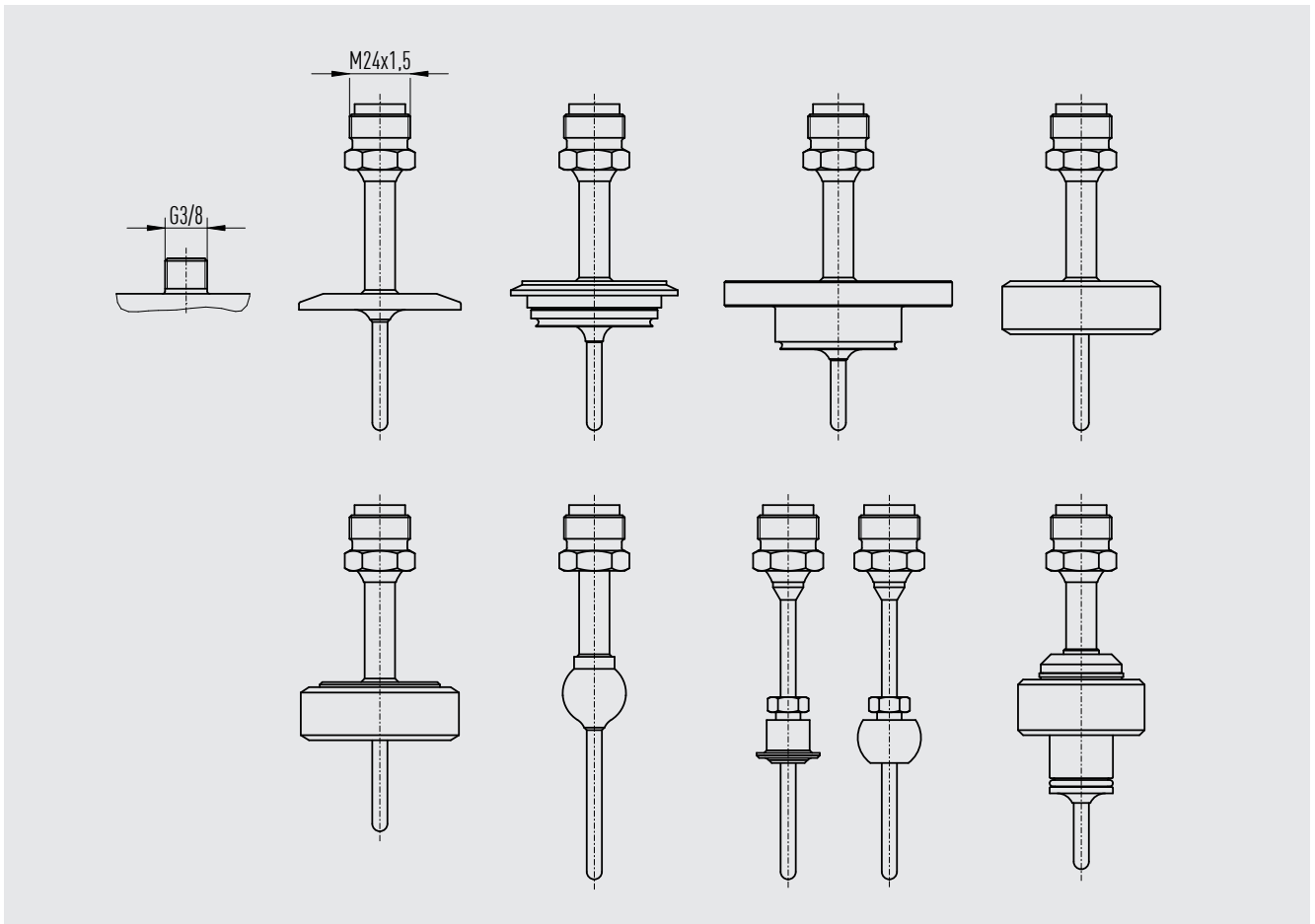

→ For details, see data sheet TW 95.22

Radio standard		
LoRaWAN®		
Specification	LoRaWAN® 868 MHz EU	
Protocol version	1.0.3	
Protocol functions	<ul style="list-style-type: none"> ■ Registration ■ Configuration ■ Sending measured values ■ Alarm management ■ Battery status 	
Frequency range	863 ... 870 MHz	
Range in free field	Typically 10 km [6 mi] → Depending on the ambient conditions, such as topography and building structures.	
Antenna	PCB antenna, internal	
Channel spacing	200 kHz	
Bandwidth	125 kHz	
Max. transmission power	14 dBm	
Transmission interval	Standard	30 minutes
	Minimum	1 minute (maximum transmission rate limited per ETSI EN 300 220) → Limitation of the transmission interval in accordance with ETSI EN 300 220 possible. The maximum transmission frequency and duty cycle comply with the standard ETSI EN300 220.
	Maximum	7 days
Security	Full end-to-end encryption per AES-128 → For details on security, see website: https://lora-alliance.org	
Bluetooth®		
Version	Bluetooth® 5.0 or newer → Compatible with all Bluetooth® Low Energy versions 4.2 or newer	
Functions	<ul style="list-style-type: none"> ■ Registration ■ Configuration ■ Sending measured values ■ Alarm management ■ Battery status ■ Data logger 	
Frequency range	2.4 GHz	
Range in free field	Typically 10 m [32.8 ft], free field → Depending on the ambient conditions, such as topography and building structures.	
Max. transmission power	4 dBm	
Antenna	Chip antenna, internal	
Transmission interval	1.25 seconds	
	→ Update of the measured value only occurs in the set measuring interval.	

→ For further information on the radio protocols, see www.wika.com.

Voltage supply and performance data		
Battery pack	Lithium thionyl chloride battery (model Tadiran SL860/S and hybrid layer capacitor (model Tadiran HLC1020L) as an assembly with connection cable assembled, see spare parts on page 9.	
Battery voltage	DC 3.6 V	
Battery life	> 10 years (measuring and transmission interval 1 hour, spreading factor 10) → At reference conditions	
Current supply	Max. 50 mA	
Measuring interval	Standard	1 minute
	Minimum	10 seconds → Smaller measuring intervals on request
	Maximum	7 days

LPWAN infrastructure

A measuring instrument that allows remote transmission via radio must be integrated into the IIoT infrastructure. The following schematic illustration shows a typical LPWAN infrastructure:

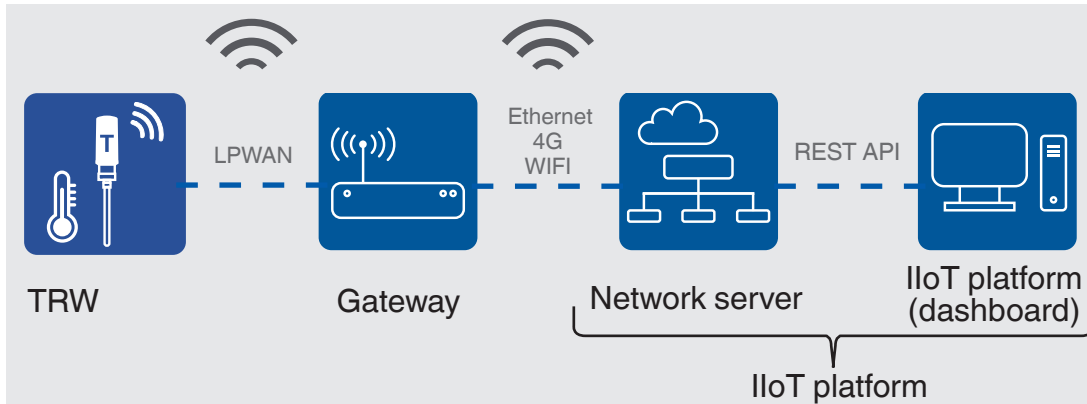

Data from an IIoT-capable measuring instrument is transmitted wirelessly via radio to the gateway. It is ensured that only authorised end devices may communicate with the network server (e.g. LoRaWAN®). For this, the measuring instrument must first be coupled with the network server. In LoRaWAN® the wireless transmission is typically 10 km [6 mi]. The range is dependent on the topography, placement of the gateway and environmental influences.

Measured values from several hundred LoRaWAN®-enabled IIoT devices can be collected by a gateway and transmitted to the network server via cable (e.g. Ethernet) or over-the-air (e.g. 4G or WLAN).

In a web-based IIoT platform, the measured data can be stored, alarms can be set and configurations can be made on the instrument. If the limit values are exceeded, alarm messages can be sent as notification via e-mail. The measured data can be analysed via the visualisation in the dashboard, thus enabling remote monitoring of the process pressure. WIKA provides the app “myWIKa wireless device” to support commissioning and local status inquiries of the measuring instrument.

“myWIKa wireless device” app

Via the “myWIKa wireless device” app, the measuring instrument can be configured.

Furthermore, the instrument data and the current measured values can be read.

The app functions are used via Bluetooth® and a Bluetooth®-capable end device.



Functions of the app:

- Indication of the instrument information
- Indication of the instrument status
- Readout of the current measured values
- Manual join request for the LoRaWAN® network
- Configuration such as measuring and transmission rate, alarm values, etc.

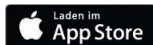

For iOS-based end devices, the app is available in the Apple Store via the link below.

[Download here:](#)



For Android-based end devices, the app is available in the Play Store via the link below.

[Download here:](#)



Material	
Materials (wetted)	
Sheath material	<ul style="list-style-type: none"> ■ Stainless steel 1.4571 ■ Stainless steel 316L
Process connection	<ul style="list-style-type: none"> ■ Stainless steel 1.4571 ■ Stainless steel 316L

Operating conditions	
Ambient temperature range	-20 ... +60 °C [-4 ... +140 °F] ¹⁾
Storage temperature range	-40 ... +70 °C [-40 ... +158 °F]
	Version with FKM O-ring -20 °C [-4 °F]
Altitude in accordance with EN 61010-1	Max. 2,000 m [6561.68 ft] above sea level
Relative humidity	20 ... 90 %, non-condensing
Maximum operating pressure ^{2) 3)}	
With sensor diameter 3 mm [0.12 in]	140 bar [2,030 psi]
With sensor diameter 6 mm [0.24 in]	270 bar [3,916 psi]
Permissible pollution degree per EN 61010-1	2
Vibration resistance per IEC 60068-2-6	5 g (10 ... 200 Hz) ⁴⁾
Shock resistance per IEC 60068-2-27	10 g, 11 ms
Free fall per IEC 60068-2-31	Individual packaging 1.2 m [3.94 ft]
Ingress protection per IEC/EN 60529	<ul style="list-style-type: none"> ■ IP65 ■ IP67
Weight	Approx. 0.05 ... 0.7 kg [0.11 ... 1.54 lbs] - depending on version

1) Version -40 ... +60°C [-40 ... +140 °F] on request:

2) Dependent on the instrument version. In combination with an additional thermowell, this determines the maximum operating pressure

3) Reduced operating pressure when using a compression fitting: Stainless steel: max. 100 bar [1,450 psi] / PTFE = max. 8 bar [116 psi]

4) Dependent on the instrument version. Specification applies to instrument versions without neck tube and for a maximum insertion length < 100 mm [3.94 in].
For insertion lengths > 100 mm [3.94 in] with limitation to 3 g max.

Alarms	
Alarms	Various alarms can be set. → See operating instructions for details

Approvals

Logo	Description	Country
CE	EU declaration of conformity	European Union
	RED - Radio Equipment Directive EN 61326 emission (group 1, class B) and immunity (industrial application) This wireless device may be used without restriction in the member states of the EU and in the countries UK, CH, NO, LI. Use in other countries is not permitted.	
	RoHS directive	

Certificates

Certificates	
Certificates	<ul style="list-style-type: none"> ■ 2.2 test report per EN 10204 (e.g. state-of-the-art manufacturing, material proof) ■ 3.1 inspection certificate per EN 10204 (e.g. material proof for wetted metal parts)

→ For approvals and certificates, see website

Dimensions in mm [in]

Legend:	$\varnothing d$ Sensor diameter
A Insertion length	X Height process connection
L1 Thread length	1/4 NPT = 15 mm [0.59 in]
N (MH) Neck length	1/2 NPT = 19 mm [0.75 in]

Process connection with parallel thread (or without process connection)

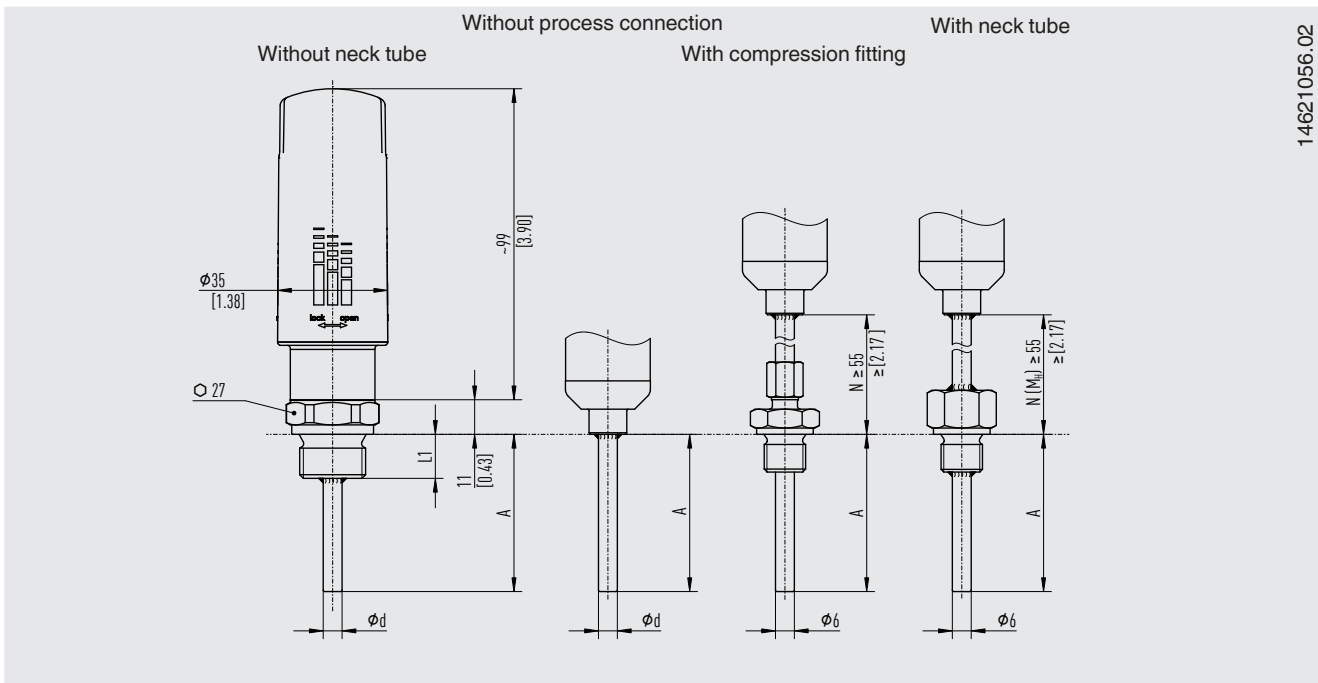

14621056.02

Process connection with parallel thread (7/16-20 UNF-2A) and O-ring

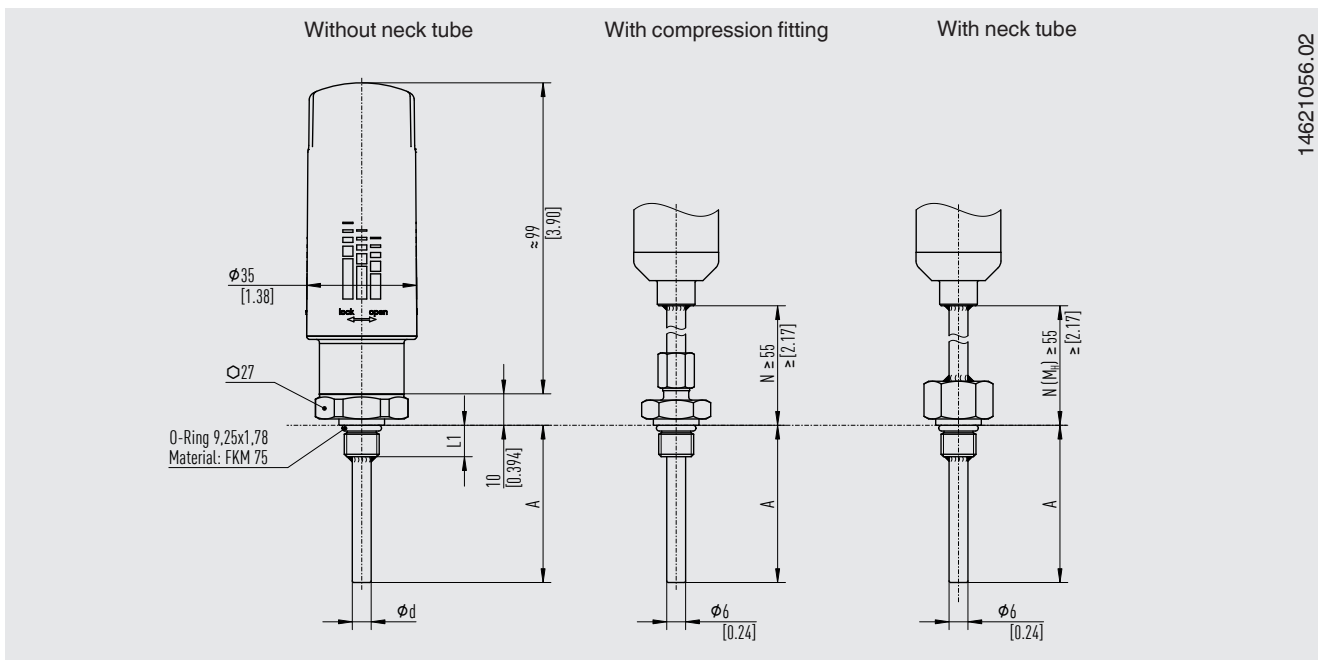

14621056.02

The FKM O-ring must be protected from temperatures lower than $-20\text{ }^{\circ}\text{C}$ [$-4\text{ }^{\circ}\text{F}$] and higher than $125\text{ }^{\circ}\text{C}$ [$257\text{ }^{\circ}\text{F}$].

Process connection with tapered thread

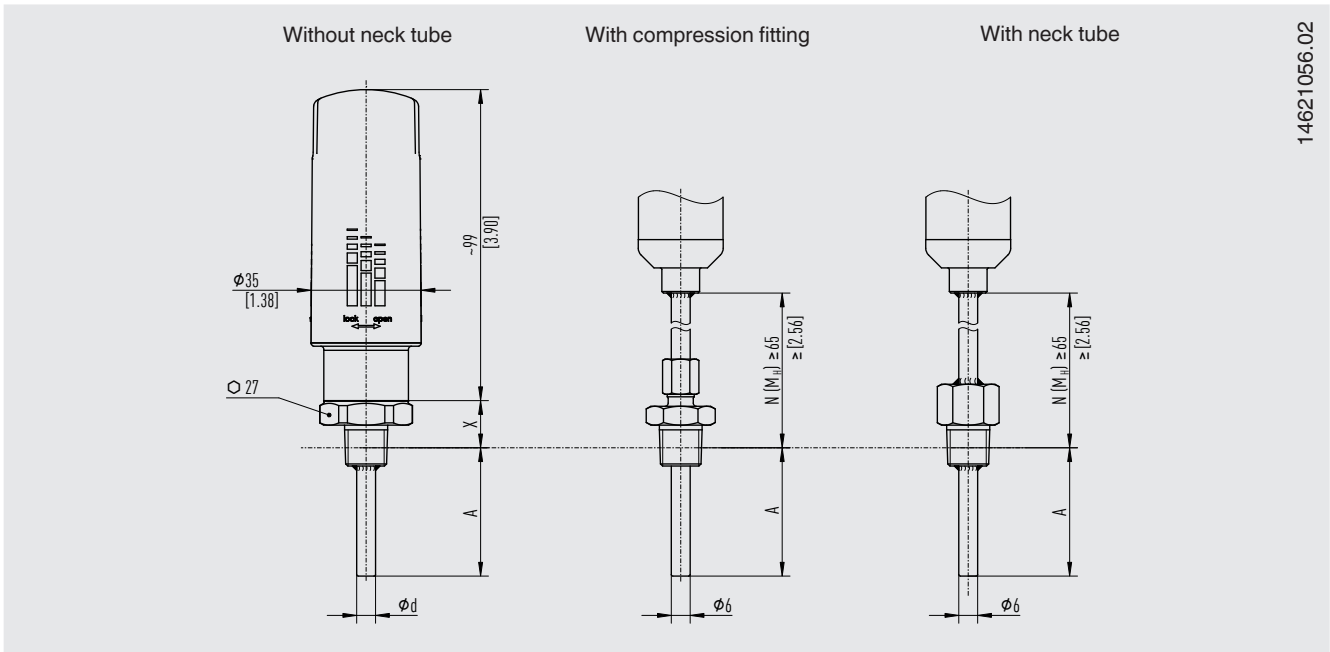

14621056.02

At a process temperature of $> 150\text{ }^{\circ}\text{C}$ [$302\text{ }^{\circ}\text{F}$], a neck length N (MH) of 70 mm [2.76 in] is necessary, otherwise N (MH) selectable (55 mm [2.17 in], 65 mm [2.56 in] or 70 mm [2.76 in]).

Spring-loaded process connection

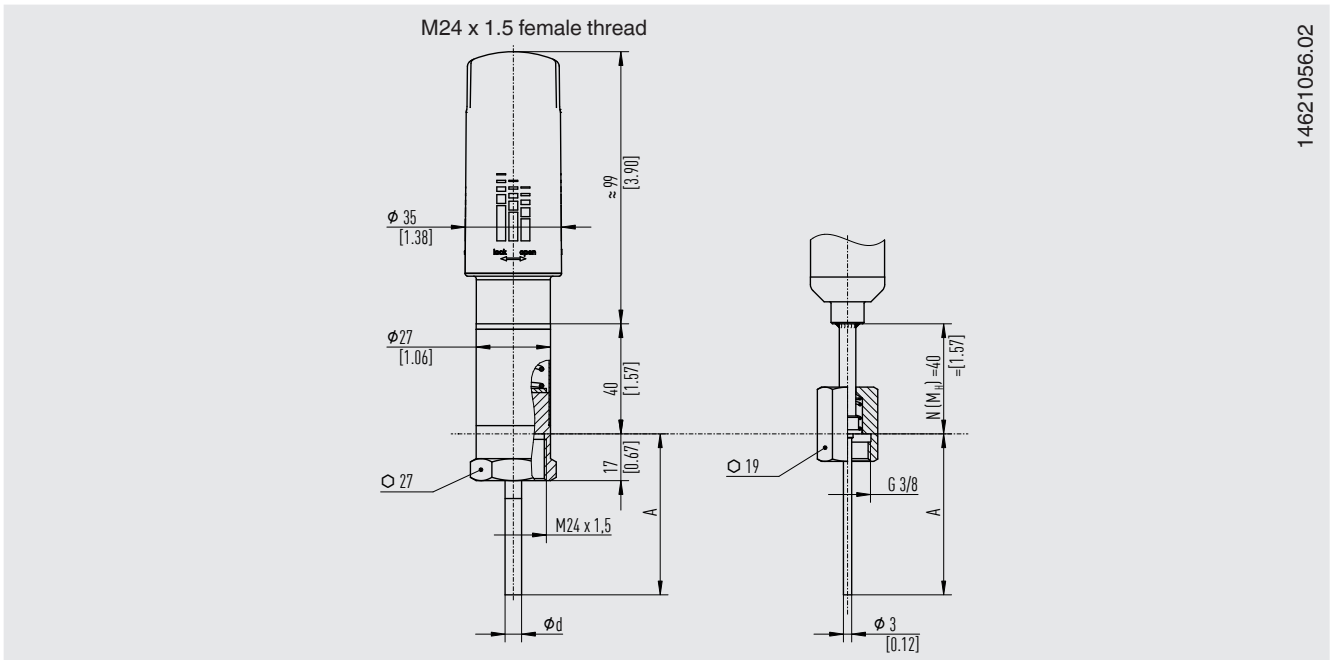

14621056.02

The neck length depends on the intended use. Usually an isolation is bridged by the neck tube. Also, in many cases, the neck tube serves as a cooling element in order to protect a possible built-in transmitter from high medium temperatures.

Process connection for surface measurement

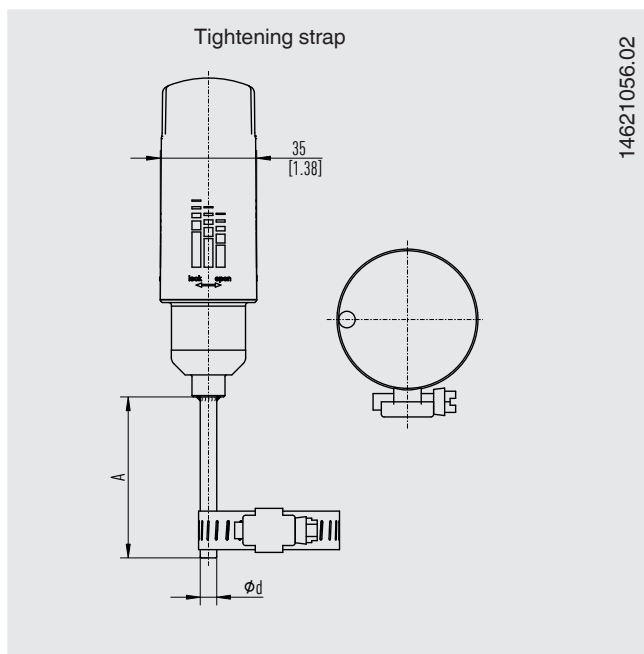

Tightening strap for pipe diameter

11 ... 15 mm [0.43 ... 0.59 in]
13 ... 25 mm [0.51 ... 0.98 in]
23 ... 62 mm [0.91 ... 2.44 in]
60 ... 93 mm [2.36 ... 3.66 in]
91 ... 125 mm [3.58 ... 4.92 in]
123 ... 158 mm [4.84 ... 6.22 in]
→ Other sizes on request: 159 ... 2,500 mm [6.26 ... 98.43 in]

→ Other process connections, see data sheet TW 95.22

Accessories

Model	Order number
LoRaWAN® gateway, preconfigured for WIKA network server	
Gateway for indoor use	On request
Gateway for outdoor use	On request

Spare parts

Model	Description	Order number
Battery	Lithium thionyl chloride battery and hybrid layer capacitor (model Tadiran HL-C1020L) as an assembly with connection cable assembled.	14392747
	Model Tadiran SL860/S	2,4 Ah

Ordering information

Model / Approvals / Process temperature / Radio standard / Region of use / Connection to platform / Process connection / Material of process connection / Sensor diameter / Sheath material / Insertion length A / Neck length N (MH) / Certificates

Configurator



To order the described product the order number is sufficient.

LoRaWAN® ist eine Marke, die unter Lizenz der LoRa-Alliance® verwendet wird.

Die Bluetooth®-Wortmarke und -Logos sind eingetragene Marken im Besitz von Bluetooth SIG, Inc. und jede Verwendung dieser Marken durch WIKA erfolgt unter Lizenz. Andere Marken und Markennamen sind Eigentum der jeweiligen Inhaber.

© 09/2023 WIKA Alexander Wiegand SE & Co. KG, all rights reserved.

The specifications given in this document represent the state of engineering at the time of publishing.

We reserve the right to make modifications to the specifications and materials.

In case of a different interpretation of the translated and the English data sheet, the English wording shall prevail.

